

Service Manual



PRISM 3001 & 2505 TestLab Mainframes

070-6676-01

Warning

The servicing instructions are for use by qualified personnel only. To avoid personal injury, do not perform any servicing unless you are qualified to do so. Refer to the Safety Summary prior to performing service.

Please check for change information at the rear of this manual.

First Printing: November 1992
Revised Printing: January 1994

Copyright © Tektronix, Inc. 1992, 1993. All rights reserved.

Tektronix products are covered by U.S. and foreign patents, issued and pending. Information in this publication supercedes that in all previously published material. Specifications and price change privileges reserved.

Printed in the U.S.A.

Tektronix, Inc., P.O. Box 1000, Wilsonville, OR 97070-1000

TEKTRONIX and TEK are registered trademarks of Tektronix, Inc.

WARRANTY

Tektronix warrants that this product will be free from defects in materials and workmanship for a period of one (1) year from the date of shipment. If any such product proves defective during this warranty period, Tektronix, at its option, either will repair the defective product without charge for parts and labor, or will provide a replacement in exchange for the defective product.

In order to obtain service under this warranty, Customer must notify Tektronix of the defect before the expiration of the warranty period and make suitable arrangements for the performance of service. Customer shall be responsible for packaging and shipping the defective product to the service center designated by Tektronix, with shipping charges prepaid. Tektronix shall pay for the return of the product to Customer if the shipment is to a location within the country in which the Tektronix service center is located. Customer shall be responsible for paying all shipping charges, duties, taxes, and any other charges for products returned to any other locations.

This warranty shall not apply to any defect, failure or damage caused by improper use or improper or inadequate maintenance and care. Tektronix shall not be obligated to furnish service under this warranty a) to repair damage resulting from attempts by personnel other than Tektronix representatives to install, repair or service the product; b) to repair damage resulting from improper use or connection to incompatible equipment; or c) to service a product that has been modified or integrated with other products when the effect of such modification or integration increases the time or difficulty of servicing the product.

THIS WARRANTY IS GIVEN BY TEKTRONIX WITH RESPECT TO THIS PRODUCT IN LIEU OF ANY OTHER WARRANTIES, EXPRESSED OR IMPLIED. TEKTRONIX AND ITS VENDORS DISCLAIM ANY IMPLIED WARRANTIES OF MERCHANTABILITY OR FITNESS FOR A PARTICULAR PURPOSE. TEKTRONIX' RESPONSIBILITY TO REPAIR OR REPLACE DEFECTIVE PRODUCTS IS THE SOLE AND EXCLUSIVE REMEDY PROVIDED TO THE CUSTOMER FOR BREACH OF THIS WARRANTY. TEKTRONIX AND ITS VENDORS WILL NOT BE LIABLE FOR ANY INDIRECT, SPECIAL, INCIDENTAL, OR CONSEQUENTIAL DAMAGES IRRESPECTIVE OF WHETHER TEKTRONIX OR THE VENDOR HAS ADVANCE NOTICE OF THE POSSIBILITY OF SUCH DAMAGES.

SOFTWARE WARRANTY

Tektronix warrants that this software product will conform to the specifications in the documentation provided with the product, when used properly in the specified operating environment, for a period of three (3) months. The warranty period begins on the date of shipment, except that if the program is installed by Tektronix, the warranty period begins on the date of installation or one month after the date of shipment, whichever is earlier. If this software product does not conform as warranted, Tektronix will provide remedial services as described in the documentation provided with the product. Tektronix does not warrant that the functions contained in this software product will meet Customer's requirements or that operation of the programs will be uninterrupted or error-free or that all errors will be corrected.

In order to obtain service under this warranty, Customer must notify Tektronix of the defect before the expiration of the warranty period and make suitable arrangements for such service in accordance with the instructions received from Tektronix. If Tektronix is unable, within a reasonable time after receipt of such notice, to provide remedial services, Customer may terminate the license for this software product and return this software product and any associated materials to Tektronix for credit or refund.

This warranty shall not apply to any software product that has been modified or altered by Customer. Tektronix shall not be obligated to furnish service under this warranty with respect to any software product a) that is used in an operating environment other than that specified or in a manner inconsistent with the User Manual and documentation or b) when the software product has been integrated with other software if the result of such integration increases the time or difficulty of analyzing or servicing the software product or the problems ascribed to the software product.

THIS WARRANTY IS GIVEN BY TEKTRONIX WITH RESPECT TO THE LISTED PRODUCT IN LIEU OF ANY OTHER WARRANTIES, EXPRESSED OR IMPLIED. TEKTRONIX AND ITS VENDORS DISCLAIM ANY IMPLIED WARRANTIES OF MERCHANTABILITY OR FITNESS FOR A PARTICULAR PURPOSE. TEKTRONIX' RESPONSIBILITY TO PROVIDE REMEDIAL SERVICE WHEN SPECIFIED, REPLACE DEFECTIVE MEDIA, OR REFUND CUSTOMER'S PAYMENT IS THE SOLE AND EXCLUSIVE REMEDY PROVIDED TO THE CUSTOMER FOR BREACH OF THIS WARRANTY. TEKTRONIX AND ITS VENDORS WILL NOT BE LIABLE FOR ANY INDIRECT, SPECIAL, INCIDENTAL, OR CONSEQUENTIAL DAMAGES IRRESPECTIVE OF WHETHER TEKTRONIX OR THE VENDOR HAS ADVANCE NOTICE OF THE POSSIBILITY OF SUCH DAMAGES.

Table of Contents

General Safety Summary	vi
Service Safety Summary	viii
Section 1	GENERAL INFORMATION
ABOUT THIS MANUAL	1-1
RELATED MANUALS	1-2
Mainframe Service Manuals	1-2
MPU Board Service Manual	1-2
Acquisition Module Service Manuals	1-2
Test Fixture Instruction Manuals	1-2
How to Order Manuals	1-2
PRODUCT DESCRIPTIONS	1-3
Mainframe	1-3
Component Descriptions	1-3
MPU Board	1-3
Keypad	1-5
Optional Keyboard	1-5
CRT Monitor	1-5
Acquisition Module	1-5
Disk Drives	1-5
Floppy Disk Drive	1-5
Hard Disk Drive	1-5
Power Supply	1-5
Probe Modules and Lead Sets	1-6
DIAGNOSTIC SOFTWARE	1-6
Section 2	SPECIFICATIONS
CHARACTERISTICS/SPECIFICATIONS	2-1
Section 3	CONNECTORS AND CABLING
CONNECTORS	3-1
MPU Assembly	3-1
Power Supply and Power Distribution Board	3-4
Power ON/OFF Control	3-5
Application Module	3-5
CRT Monitor	3-6
Floppy Disk Drive	3-6
Hard Disk Drive	3-6
Section 4	THEORY OF OPERATIONS
LOGIC CONVENTIONS	4-1
MAINFRAME COMPONENT DESCRIPTIONS	4-2
Keyboard Filter Board	4-2
Keypad	4-3
Optional Keyboard Module	4-4
Keypad/Optional Keyboard Communications	4-4

	To MPU Board.....	4-5
	From MPU Board.....	4-5
	Connector Adapter Board.....	4-6
	CRT Display Module.....	4-6
	Power Supply Module.....	4-7
	General Description.....	4-8
	Power Distribution.....	4-8
	Power Distribution Circuit Board.....	4-9
	Soft Power Control.....	4-9
	Floppy Disk Drive.....	4-10
	Hard Disk Drive.....	4-10
	Hard Drive IDE Interface Board (IDE Interface Family).....	4-11
	Hard Disk Controller Board (ST506/412 Interface Family)....	4-11
Section 5	VERIFICATION AND ADJUSTMENT PROCEDURES	
	REQUIRED TEST EQUIPMENT.....	5-1
	OPERATING A MAINFRAME IN THE SERVICE POSITION....	5-2
	FUNCTIONAL CHECK PROCEDURES.....	5-3
	TestLab Functional Verification Using System Diagnostics...	5-3
	PERFORMANCE VERIFICATION PROCEDURES.....	5-4
	SCLK TekLink Clock Check.....	5-4
	DC Voltage Power Supply Checks.....	5-4
	ADJUSTMENT PROCEDURES.....	5-7
	Equipment Set-up.....	5-9
	CRT Adjustments.....	5-9
Section 6	DISASSEMBLY/ASSEMBLY	
	GENERAL DISASSEMBLY/INSTALLATION PRECAUTIONS .	6-1
	MAINFRAME DISASSEMBLY/ASSEMBLY.....	6-2
	Procedure A. Mainframe Cover.....	6-2
	Procedure B. Application module.....	6-4
	Procedure C. MPU Board and Connector Adapter Board.....	6-5
	Procedure D. Hard Disk Drive Assembly.....	6-7
	Procedure D-1. Hard Disk and IDE Interface Board (IDE Interface Family).....	6-7
	Procedure D-2. Hard Disk and Hard Disk Controller (ST506/412 Interface Family).....	6-8b
	Procedure E. Floppy Disk Drive.....	6-9
	Procedure F. Power Supply Module and Power Distribution Board.....	6-11
	Procedure G. Front Panel Assembly and Keypad.....	6-12
	Procedure H. Display Control Board.....	6-14
	Procedure I. CRT.....	6-15
	Procedure J. Fan.....	6-16
	OPTIONAL KEYBOARD DISASSEMBLY/ASSEMBLY.....	6-17
	Replacing Keycaps.....	6-17
	Replacing the Keyboard Cable.....	6-18
	PLACEMENT OF MODULES FOR TROUBLESHOOTING.....	6-20

Section 7	MAINTENANCE	
	SERVICE STRATEGY	7-1
	MAINTENANCE TOOLS.....	7-2
	MAINTENANCE PRECAUTIONS.....	7-2
	CRT Display Monitor	7-3
	Soldering.....	7-4
	Static Precautions	7-4
	AC Voltage Select Switch	7-5
	PREVENTIVE MAINTENANCE.....	7-5
	Exterior Cleaning.....	7-6
	Interior Cleaning.....	7-6
	Inspection	7-6
	CORRECTIVE MAINTENANCE	7-7
	Obtaining Replacement Parts	7-7
	Circuit Board Pin Replacement	7-8
Section 8	TROUBLESHOOTING	
	TROUBLESHOOTING EQUIPMENT	8-1
	TROUBLESHOOTING PRECAUTIONS	8-2
	Component Handling.....	8-2
	The CRT Display	8-2
	PLACEMENT OF MODULES FOR TROUBLESHOOTING.....	8-3
	GENERAL TROUBLESHOOTING	8-3
	Troubleshooting System Power.....	8-3
	Power Distribution.....	8-4
	Power Supply Troubleshooting Chart.....	8-4
	Troubleshooting Thermal Conditions	8-4
	Keypad and Optional Keyboard Troubleshooting	8-7
	Cable	8-7
	Power	8-7
	Disk Drive Troubleshooting.....	8-7
	CRT Display Monitor Troubleshooting.....	8-8
	COMM Pack Troubleshooting	8-8
Section 9	Replaceable Electrical Parts	
Section 10	Diagrams	
Section 11	Replaceable Mechanical Parts	

List of Figures

Figure 1-1.	Configuration diagram.....	1-4
Figure 2-1.	Mainframe physical dimensions.....	2-3
Figure 2-2.	Optional Keyboard physical dimensions.....	2-4
Figure 2-3.	Video timing.....	2-20
Figure 3-1.	MPU board connectors and pin keying.	3-2
Figure 3-2.	Connector Adapter board for MPU board.	3-3
Figure 3-3.	Keyboard Filter board connector and pin configuration.	3-4
Figure 4-1.	Keypad and optional keyboard communications block diagram.....	4-3
Figure 4-2.	Video block diagram.	4-7
Figure 4-3.	Power Supply control circuitry.	4-9
Figure 4-4.	Hard Disk Controller basic block diagram.....	4-12
Figure 5-1.	Power Supply test points on MPU board.	5-5
Figure 5-2.	Optimum size and positioning for display area.....	5-7
Figure 5-3.	CRT display adjustment locations.....	5-10
Figure 5-4.	Centering ring locations on CRT yoke.	5-12
Figure 6-1.	Removing the mainframe cover.	6-3
Figure 6-2.	Removing the application module.	6-4
Figure 6-3.	MPU and Connector Adapter board removal.....	6-6
Figure 6-4.	Removing the hard disk drive assembly.	6-7
Figure 6-5.	The hard disk drive assembly.....	6-8
Figure 6-5a.	Connecting the hard disk drive cable.....	6-8a
Figure 6-5b.	Hard disk bracket screws.....	6-8c
Figure 6-5c.	Hard disk drive and controller.	6-8d
Figure 6-6.	Removing the Floppy Disk Drive.....	6-10
Figure 6-7.	Removing Keypad circuit board from Front Panel Assembly.....	6-13
Figure 6-8.	Replacing keycaps.	6-18
Figure 6-9.	Keycap templates.	6-19
Figure 6-10.	MPU board and Application module in troubleshooting position.....	6-21
Figure 7-1.	Circuit board pin replacement.	7-9
Figure 8-1.	Power supply troubleshooting chart.....	8-5
Figure 8-2.	Thermal sensor wiring.	8-6

List of Tables

Table 2-1. Physical Characteristics	2-2
Table 2-2A. Environmental Specifications Without Hard Disk.....	2-5
Table 2-2B. Environmental Specifications With Hard Disk	2-6
Table 2-3. Environmental Requirements (IEC).....	2-6
Table 2-4. Reliability	2-7
Table 2-5. Installation Requirements.....	2-7
Table 2-6. Power Supply Performance Requirements	2-8
Table 2-7. Floppy Disk Drive Functional Specifications	2-10
Table 2-8. HEX Keypad Performance Specifications.....	2-11
Table 2-9. HEX Keypad Key Codes	2-12
Table 2-10. Function Key Codes	2-13
Table 2-11. Keyboard Performance Specifications	2-14
Table 2-12. Optional Keyboard Key Codes.....	2-15
Table 2-13. Keyboard Function Key Codes	2-17
Table 2-14. Keypad Key Codes (HEX).....	2-18
Table 2-15. Hard Disk Functional Specifications	2-19
Table 2-16. CRT Monitor Functional Specifications.....	2-19
Table 5-1. Required Test Equipment.....	5-2
Table 5-2. TekLink Clock Frequency Specification	5-4
Table 5-3. Power Supply Tolerances.....	5-5
Table 6-1. Keyboard Cable Pinout and Color-code	6-18

GENERAL SAFETY SUMMARY

The general safety information in this summary is for operating and servicing personnel. Specific warnings and cautions can be found throughout the manual where they apply, and may not appear in this summary.

TERMS IN THIS MANUAL

CAUTION

CAUTION statements identify conditions or practices that could result in damage to the equipment or other property.

WARNING

WARNING statements identify conditions or practices that could result in personal injury or loss of life.

TERMS AS MARKED ON EQUIPMENT

CAUTION indicates a hazard to property, including the equipment itself, and could cause minor personal injury.

WARNING indicates solely a personal injury hazard not immediately accessible as you read the marking.

DANGER indicates a personal injury hazard immediately accessible as you read the marking.

SYMBOLS AS MARKED ON EQUIPMENT



DANGER—High voltage.



Protective ground (earth) terminal.



ATTENTION—REFER TO MANUAL.

GROUNDING THE PRODUCT

This product is intended to operate from a power source that does not apply more than 250 volts rms between the supply conductors or between either supply conductor and ground.

WARNING: This product is grounded through the grounding conductor of the power cord. To avoid electrical shock, plug the power cord into a properly wired receptacle. A protective-ground connection by way of the grounding conductor in the power cord is essential for safe operation. (I.E.C. Safety Class I)

DANGER ARISING FROM LOSS OF GROUND

Upon loss of the protective-ground connection, all accessible conductive parts (including knobs and controls that may appear to be insulated) can render an electric shock.

POWER DISCONNECT

The main power disconnect is by means of the power cord or, if provided, an ac power switch.

USE THE PROPER POWER CORD

Use only the power cord and connector specified for your product. Use only a power cord that is in good condition. CSA Certification includes the equipment plus those power cords appropriate for use on the North America power network. All other power cords supplied are approved for the country of use.

USE THE PROPER FUSE

To avoid fire hazard use only a fuse of the correct type, voltage rating, and current rating.

USE THE PROPER VOLTAGE SETTING

Make sure the line selector is in the proper position for the power source being used.

REMOVE LOOSE OBJECTS

During disassembly or installation procedures, screws or other small objects may fall to the bottom of the mainframe. To avoid shorting out the power supply, do not power-up the instrument until such objects have been removed.

DO NOT OPERATE WITHOUT COVERS

To avoid personal injury or damage to the product, do not operate this product with covers or panels removed.

USE CARE WITH COVERS REMOVED

To avoid personal injury, remove jewelry such as rings, watches, and other metallic objects before removing the cover. Do not touch exposed connections and components within the product while the power cord is connected.

REMOVE FROM OPERATION

If you have reason to believe that the instrument has suffered a component failure, do not operate the instrument until the cause of the failure has been determined and corrected.

DO NOT OPERATE IN EXPLOSIVE ATMOSPHERES

To avoid explosion, do not operate this product in an explosive atmosphere unless it has been specifically certified for such operation.

SERVICE SAFETY SUMMARY

Only qualified personnel should perform service procedures. This Service Safety Summary and the General Safety Summary should be read before performing service procedures.

DO NOT SERVICE ALONE

Do not perform internal service or adjustment of this product unless another person capable of rendering first aid and resuscitation is present.

USE CARE WHEN SERVICING WITH POWER ON

To avoid personal injury from high current, remove jewelry such as rings, watches, and other metallic objects, before servicing the instrument. Do not touch exposed connections and components while power is on. Disconnect power before soldering, removing protective panels, or replacing components.

USE CAUTION WHEN SERVICING THE CRT

The CRT assembly should be replaced only by qualified personnel familiar with CRT servicing procedures and precautions. CRTs retain hazardous voltages for long periods of time after power-down. Before attempting any work inside the monitor, discharge the CRT by shorting the anode to chassis ground. When discharging the CRT, connect the discharge path to ground and then the anode. Use extreme caution when handling the CRT, rough handling may cause it to implode. Do not nick or scratch the glass or subject it to undue pressure during removal or installation. When handling the CRT, wear safety goggles and heavy gloves for protection.

Section 1

GENERAL INFORMATION

ABOUT THIS MANUAL

This manual contains service information for the Tektronix PRISM 3001 Series and 2505 TestLab electronic measurement and analysis mainframes; hereafter referred to as mainframe.

The information in this manual explains how to verify, service, troubleshoot, and repair the mainframe and its internal components. Service information for the MPU board and application modules is provided in separate manuals.

This manual contains the following information:

Section 1, *General Information*, briefly describes related manuals, the mainframe (and related components), and service strategy.

Section 2, *Specifications*, describes functional characteristics and performance requirements of the mainframe and associated modules.

Section 3, *Connectors and Cabling*, provides text and illustrations that describe electrical connections between internal electrical modules and chassis-mounted electrical components. Also explains where additional connector and cabling information is located in this manual.

Section 4, *Theory of Operation*, provides descriptions of mainframe modules. General and detailed descriptions of circuitry are provided. If a board is not repaired at the user site, use the general description. If component-level repair is supported, use the detailed descriptions.

Section 5, *Verification and Adjustments*, describes how to verify the functional performance of the mainframe and how to perform adjustments.

Section 6, *Disassembly/Installation*, describes how to remove and replace mainframe modules.

Section 7, *Maintenance*, describes how to perform maintenance on the mainframe.

Section 8, *Troubleshooting*, describes general troubleshooting procedures for mainframe modules.

Section 9, *Electrical Parts List*, lists all the replaceable electrical parts associated with the mainframe. Parts for modules supported with separate service manuals are not included.

Section 10, *Diagrams*, contains block diagrams, interconnect wiring/signal diagrams, and schematics for the mainframe and selected modules.

Section 11, *Mechanical Parts List*, lists the replaceable mechanical parts for the mainframe.

RELATED MANUALS

Service information for a signal analyzer system is contained in several different service manuals. Thus, a service manual package and service kit accessories will vary depending on the particular mainframe and installed application module. Service information is contained in the following types of service manuals.

Mainframe Service Manuals

These manuals provide service information for the different mainframe mechanical enclosures and associated chassis-mounted components. Mainframe service manuals also contain service information for system peripherals; such as, hex keypad or keyboard, power supply, floppy disk drive, hard disk controller and drive, and display unit.

MPU Board Service Manual

The *MPU Board Service* manual provides detailed service information for the MPU Board that is installed in a mainframe. It contains descriptions of functional circuits on the MPU board, as well as detailed system-level troubleshooting information. Its *Troubleshooting* section describes how to troubleshoot an MPU board and associated modules. Its *System Diagnostic Software* section describes how to use diagnostic software to exercise specific MPU and mainframe electronics for troubleshooting and verification. Here you will find explanations on how to enter and exit Diagnostic mode, how to use diagnostics for system verification and/or troubleshooting, and a detailed description of each diagnostic test.

Acquisition Module Service Manuals

The mainframe can contain one of several different application modules. Each application module is supported with its own service manual.

Acquisition module service manuals also provide service information for probes and lead sets.

Test Fixture Instruction Manuals

Special test fixtures are available to aid low-level servicing of selected acquisition boards. Instruction manuals describe how to use and service this special test fixture.

How to Order Manuals

Manuals not shipped as a standard accessory with your product may be ordered individually or as part of a service kit. Contact your Tektronix representative for a complete list of related manuals and service kits for your particular mainframe configuration.

PRODUCT DESCRIPTIONS

The basis of the product is a single-host MPU board and an application module board. In addition, the mainframe contains a power supply, a floppy disk drive, a hard disk drive, a hex keypad (or optional keyboard), and a monochrome CRT monitor. With specially-designed system and application software, the result is a custom electronic measurement system tailored to a specific application.

Mainframe

The mainframe is the main electronic enclosure for an instrumentation system. It is a stand-alone device used for test and signal acquisition tasks. Shown in Figure 1-1, the mainframe is configured with an MPU board, a hex keypad, an optional keyboard, a CRT monitor, a power supply, a floppy disk drive, hard disk drive and controller, and an application module.

Component Descriptions

The following provides a brief description of each electrical module as you might find it configured in a mainframe system. Refer to *Section 4 Theory of Operation*, for functional descriptions of the modules used in the mainframe.

Refer to Figure 1-1 when reading the following.

MPU Board

The MPU board is a single-board host computer that provides central control and memory for an instrumentation system. It is based on a Motorola 68010 microprocessor, 2 Mbyte or 4 Mbyte (later version) RAM, and 32 Kbyte of boot ROM.

The MPU board provides a standard RS-232C port for host communications and a modified RS-232C port for keypad and keyboard communications. It also provides a Tektronix 1200-Series COMM Pack port for RS-232C, GPIB, and parallel printer interfacing. A 640 X 400 non-interlaced display output provides connection for the CRT monitor.

Most modules within the mainframe connect to the MPU board. The CRT and application modules connect to the MPU board via the Connector Adapter board. The keypad and optional keyboard connect to the MPU board via the Keyboard Filter board. Refer to the *MPU Board Service* manual for MPU board service information.

General Information

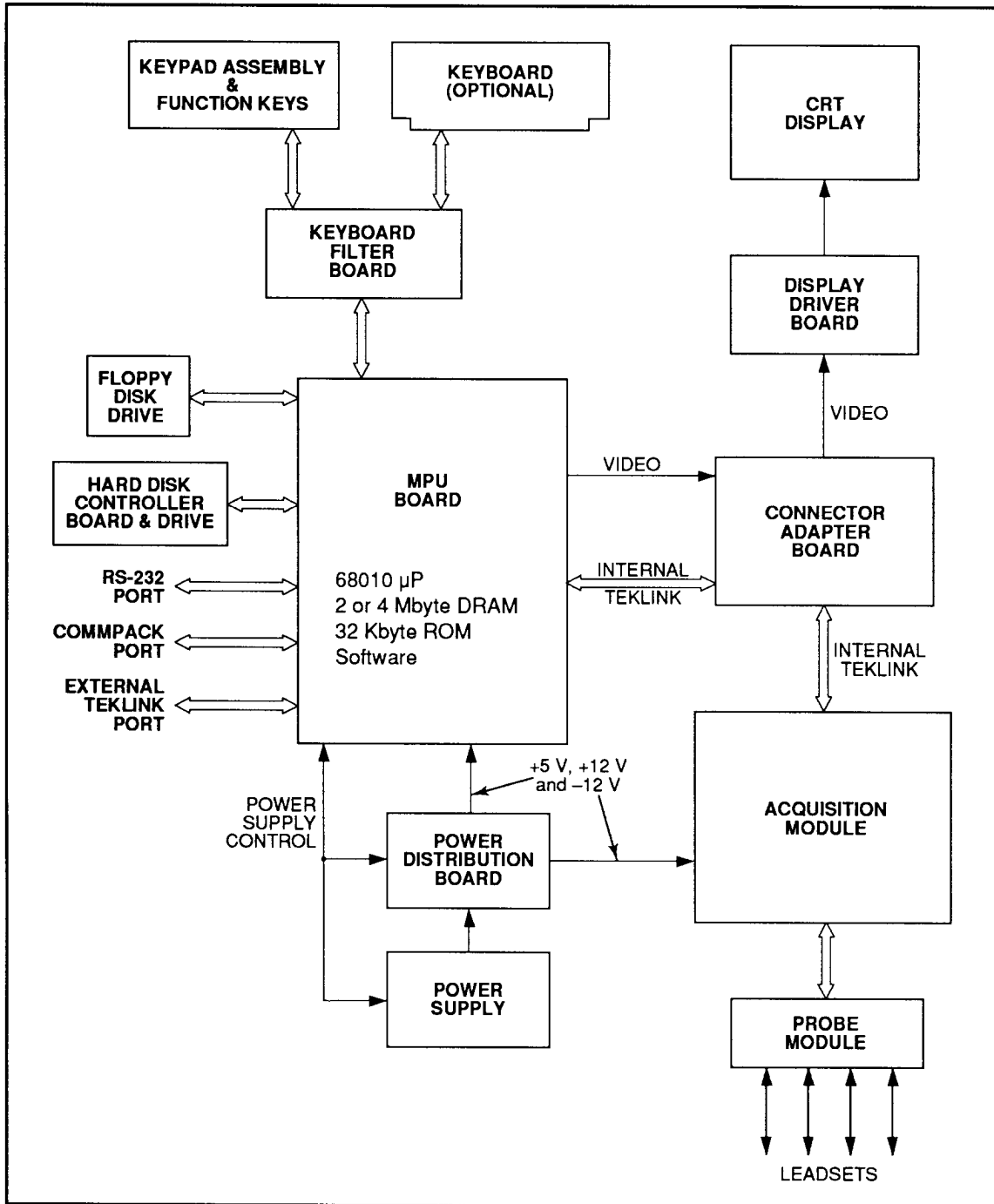

Figure 1-1. Configuration diagram.

Keypad

The keypad consists of a hex keypad, cursor-control keys, special purpose keys, select keys, and a select knob. A row of eight special function keys are located on the front panel directly under the the CRT.

Optional Keyboard

The keyboard consists of a standard QWERTY keyboard, special-function keys, and a control knob.

CRT Monitor

The MPU board provides a 640 X 400 pixel, non-interlaced display output to drive an internal monochrome CRT monitor.

Acquisition Module

An application module interfaces to the MPU board through special interface hardware and communications protocol (TekLink). Separate but functionally identical links are provided by the MPU board for one internal and one or two external application modules. External application modules reside in an Expansion mainframe and connect to the MPU board using external TekLink cabling.

NOTE

Service information for application modules is provided in separate service manuals. See Related Manuals for an explanation of related manuals and ordering information.

Disk Drives

The PRISM 3001 Series mainframes include a floppy disk drive; an optional hard disk drive is available. The 2505 TestLab mainframe contains a floppy and a hard disk drive.

Floppy Disk Drive

A 3.5 inch, hard-shell disk drive provides storage for operating system software, diagnostics software, applications software, and acquisition data files.

Hard Disk Drive

A hard disk drive is provided in the 2505 TestLab mainframe for mass storage. A hard disk drive is optionally available for the PRISM 3001 Series mainframes. An associated circuit board provides interfacing between the MPU board and the hard disk drive.

Power Supply

A power supply provides +5 VDC, +12 VDC and -12 VDC to mainframe modules. The MPU board and application module receive power directly from the power supply using separate distribution buses. All other modules receive power distributed by the MPU board.

General Information

Probe Modules and Lead Sets

Different probe modules are available for connecting an application module to the system under test (SUT). The probe module used depends on the physical requirements of the circuitry to be observed or tested. A probe module uses a lead set to physically connect the probe to the system under test. Again, different lead sets are available depending on the specific probe and physical requirements of the system to be observed or tested. Service information for probes and lead sets is provided in application module service manuals.

DIAGNOSTIC SOFTWARE

Comprehensive diagnostic software supports both automatic power-up tests and menu-driven self-tests. For more information about diagnostic software refer to your system user's manual.

Section 2 SPECIFICATIONS

This section lists two types of specifications: (1) those that are classified as environmental, physical, or "static" specifications (specifications that cannot be verified by the user); and (2) those that are actual operational parameters (specifications that are user verifiable). Refer to the Verification and Adjustment procedures in Section 5 for procedures that verify the performance specifications.

The following terms are used in the specifications tables:

Characteristic: A property of the product.

Performance Requirement: The primary performance characteristics of the product that can be verified using verification procedures.

Supplemental Information: Statements that describe typical performance for characteristics of secondary importance (those that are not usually verified using verification procedures) or statements that further explain related performance requirements.

CHARACTERISTICS/SPECIFICATIONS

The performance characteristics in this section are valid under the following conditions:

1. The mainframe must be operating in an environment as specified in Table 2-2 or Table 2-3 in Environmental Specifications.
2. A warm-up period of at least 20 minutes must precede the verification/operational procedures.
3. The mainframe power supplies must meet specified power requirements as listed in Power Supply Specifications, Table 2-6.

Specifications

The following tables list the specifications and performance characteristics of the Mainframes:

- 2-1 Physical Characteristics
- 2-2 Environmental Specifications Without Hard Disk
- 2-3 Environmental Specifications With Hard Disk
- 2-4 Reliability
- 2-5 Installation Requirements
- 2-6 Power-Supply Performance Specifications
- 2-7 Floppy-Disk Functional Specifications
- 2-8 Hex Keypad Performance Specifications
- 2-9 Hex Key Codes
- 2-10 Function Key Codes
- 2-11 Optional Keyboard Performance Specifications
- 2-12 Optional Keyboard Key Codes
- 2-13 Optional Keyboard Function Key Codes
- 2-14 Optional Keyboard Keypad Key Codes
- 2-15 Hard Disk Functional Specifications
- 2-16 CRT Monitor Functional Specifications

Table 2-1
Physical Characteristics

Characteristic	Description
Weight	
Mainframe (includes application module)	28 lbs (12.7 kg)
Overall Dimensions	See Figures 2-1 and 2-2.

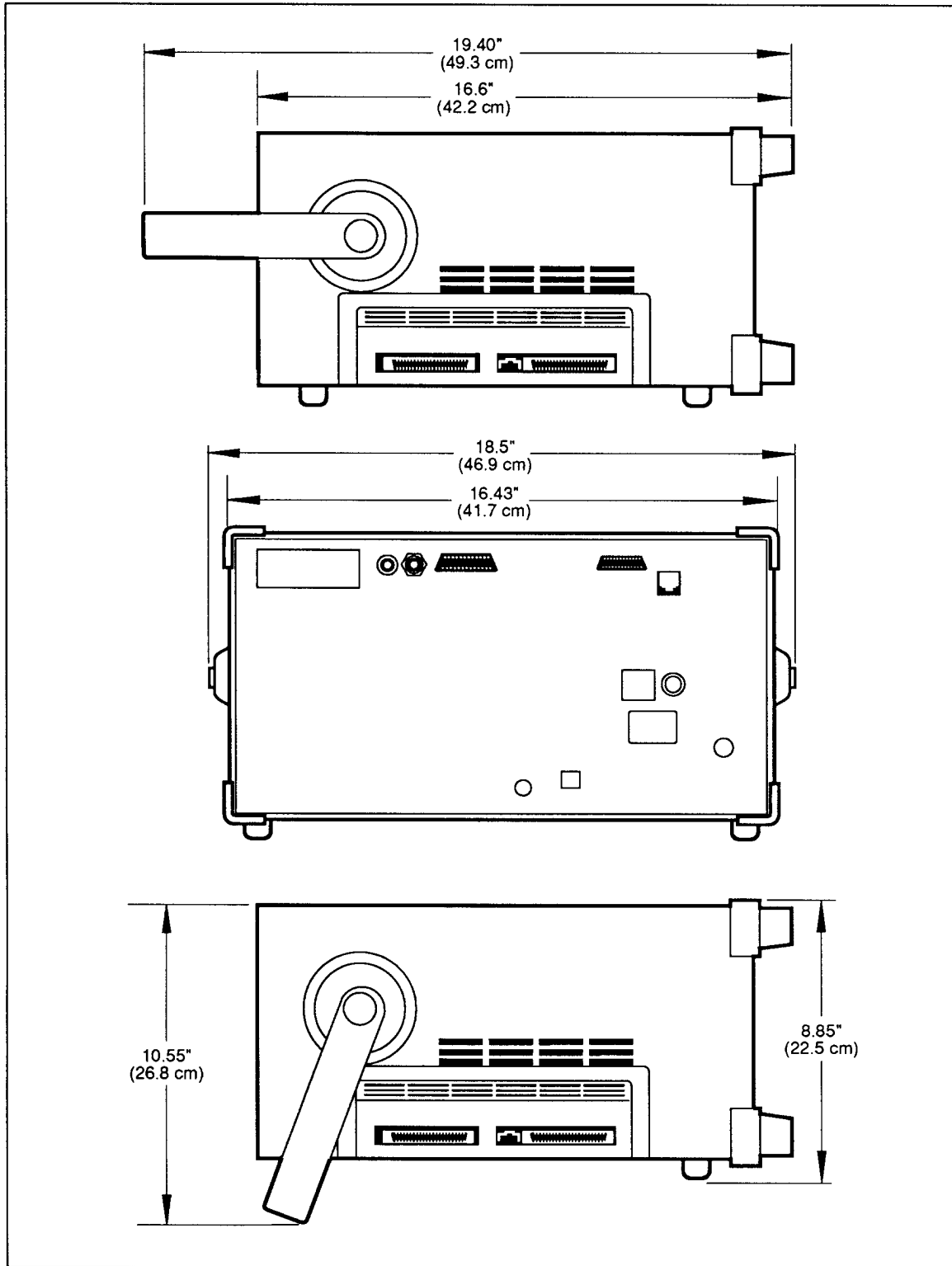

Figure 2-1. Mainframe physical dimensions.

Specifications

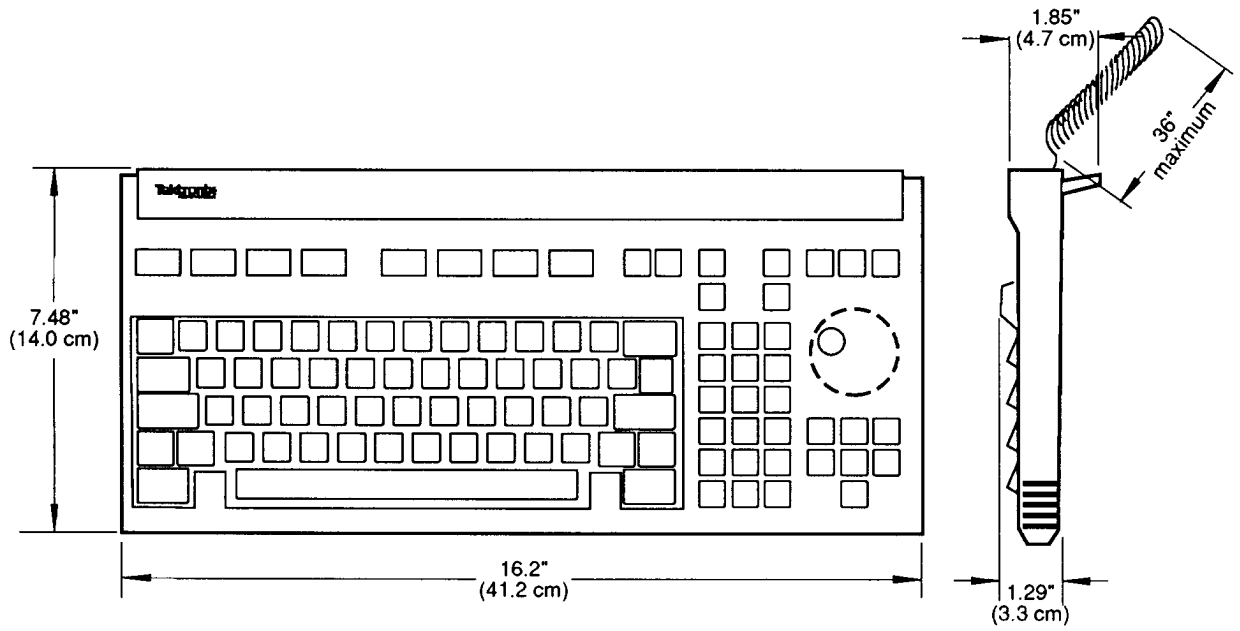

Figure 2-2. Optional Keyboard physical dimensions.

**Table 2-2A
Environmental Specifications Without Hard Disk**

Characteristic	Description
Temperature	
operating	+5°C to +50°C
non-operating	-22°C to +60°C
Humidity	
max wet bulb	29°C
operating (relative humidity)	20% to 80%
non-operating (non-condensing)	10% to 90%
Altitude	
operating	10 000 ft (3 km)
non-operating	30 000 ft (9 km)
Vibration	
operating	0.25 in p-p @ 10-34 Hz 1.5 G @ 34-55 Hz
non-operating	0.25 in p-p @ 10-49 Hz 3.0 G @ 49-55 Hz
Shock	
operating	3 G
non-operating	50 G (11 ms duration)
Electrostatic Discharge	No permanent damage from a discharge of 20 kV through a 1 kΩ resistor in series with a 500 pF capacitor.
Electromagnetic Susceptibility	RS01, RS02, RS03 CS01, CS02, CS06

Specifications

**Table 2-2B
Environmental Specifications With Hard Disk**

Characteristic	Description	Supplemental Information
Temperature operating	+5°C to +50°C	
non-operating	-22°C to +60°C	
Humidity operating	20% to 80% (26°C max. wet bulb temp.)	limit is hard disk
non-operating	10% to 90% (non-condensing) (26°C max. wet bulb temp.)	limit is hard disk
Altitude operating	10 000 ft (3 km) (decrease operating temperature 1°C for each 1000 ft above 5000 ft)	
non-operating	30 000 ft (9 km)	
Vibration operating	0.015 in p-p (5 Hz - 22 Hz) 0.5 G (22 Hz - 55 Hz)	limit is hard disk
non-operating	0.162 in p-p (10 Hz - 22 Hz) 4.0 G (22 Hz - 55 Hz)	limit is hard disk
Shock operating	2 G @ 11 ms	limit is hard disk
non-operating	50 G @ 11 ms	limit is hard disk
Electrostatic Discharge	No permanent damage from a discharge of 20 kV through a 1 kΩ resistor in series with a 250 pF capacitor	
Electromagnetic Susceptibility	RS01, RS02, RS03 CS01, CS02, CS06	

**Table 2-3
ENVIRONMENTAL REQUIREMENTS (IEC)**

Characteristic	Description
IEC Requirement	IEC Installation Category II IEC Pollution Degree 2 IEC Safety Class I

**Table 2-4
Reliability**

Characteristic	Description
Mean Time Between Failures (MTBF)	2500 hours. (Includes MPU board, display unit, power supply, floppy disk, and hex keypad or optional keyboard.)

**Table 2-5
Installation Requirements**

Characteristic	Description
Heat Dissipation Typical Max. Load	637 BTU/hr 774 BTU/hr
Surge Current	15 A @ 115 VAC first half cycle 30 A @ 230 VAC first half cycle
Cooling Clearance With Wrap-around removed	6 inches on left and right sides When operating instrument with wrap-around removed, the internal fan does not supply adequate cooling for the circuit boards. When operating instrument with wrap-around removed, use an external fan to blow air across the boards.

Specifications

**Table 2-6
Power Supply Performance Requirements**

Characteristic	Performance Requirement	Supplemental Information
Description		A 140 watt, switching power power supply with outputs for +5, +12 and -12 VDC.
AC Power Input		
Voltage	95-132 VAC 180-250 VAC	switch selectable switch selectable
Frequency	48-63 Hz	
Line Fuse	115 VAC 230 VAC	3 A fast-blow fuse 2 A fast-blow fuse
Holding Time		≥16 ms at full-rated load and nominal input voltage
DC Power Output (general information)		
Power Output		140 watts continuous
Ground Return		
+5 V (main output)	+5 VDC nominal	±5% adjustment (minimum)
Regulation	+5 VDC +5%/-2.5%	
Ripple	<100 mV p-p	Measured differentially

Table 2-6(cont.)
Power Supply Performance Requirements

Characteristic	Performance Requirement	Supplemental Information
Output Current		20 A max MPU Board
Current Limit		Prolonged overload results in system shutdown. System is reset by disconnecting and reconnecting the power cable.
Over-voltage		+6.0 to 6.5 VDC. Over-voltage condition protection shuts down supply. Reset supply by disconnecting and reconnecting the power cable.
+12 V (Aux output #1)		
Regulation	±5%	
Ripple	120 mV p-p	
Output Current		5 A
Output overload/ short circuit protection		Prolonged overload condition results in system shut-down. System is reset by disconnecting and reconnecting the power cable.
-12 VDC (Aux outputs #2 and #3)		
Regulation	±5%	
Ripple	100 mV p-p	
Output Current		3.0 A
Current Limit		Outputs are individually foldback current limited at 4 A and short circuit protected. System recovery is automatic when load is reduced.

Specifications

Table 2-7
Floppy Disk Drive Functional Specifications

Characteristic	Description
Description	Half-height, 3.5 inch, 1.0 Mbyte (unformatted), double sided.
Unformatted Capacity	
Per Disk	1 Mbyte
Per Surface	512 Kbyte
Per Track	6.25 Kbyte
Formatted Capacity	
Per Disk	720 Kbyte
Per Track	4.096 Kbyte
Per Sector	0.256 Kbyte
Transfer Rate	250 Kbit/s
Access Time	
Track-to-track	3 ms maximum
Average	100 ms maximum
Settling Time	15 ms maximum
Input Power	
DC Voltage	+5 V +5%
Input Current	0.32 A typical (1.1 A maximum)
Ripple	100 mV
Standby	9 mA

**Table 2-8
HEX Keypad Performance Specifications**

Characteristic	Performance Requirement	Supplemental Information
Description		A general purpose control panel that consists of a hex pad and menu, cursor, execute, select, return, shift , and print keys. Eight special functions keys connect to control panel.
Clock		19.2 kHz \pm 3%
Serial Data Protocol		19.2 Kbaud, synchronous One start bit, 8 data bits, one stop bit, no parity.
Programmable parameters		
Clock Rate		The number of degrees the knob is rotated before the panel signals the MPU that the knob has been turned.
Period		The time period over which the clicks are accumulated.
Mode		Forces control panel into normal mode as opposed to knob mode.
Repeat Key Lag		0.5 seconds.
Repeat Key Rate		10 per second
Function Key Codes		See Table 2-10 (codes are shown in hexadecimal)
Input Power		
DC Voltage	+5 V \pm 5%	Regulation occurs within the control panel circuitry.
DC Current		1 A maximum

Specifications

**Table 2-9
HEX Keypad Key Codes
(for PRISM and TestLab keypads)**

Key Label		Unshifted	Shifted
PRISM	TestLab		
0	0	80	D3
1	1	81	D4
2	2	82	D5
3	3	83	D6
4	4	84	D7
5	5	85	D8
6	6	86	D9
7	7	87	DA
8	8	88	DB
9	9	89	DC
A	m	8A	DD
B	μ	8B	DE
C	n	8C	DF
D	HELP	8D	E0
E	AUTOSET	8E	E1
F	HOME MENU	8F	E2
X	X	E3	E4
HELP NOTES	.	EE	ED
SELECT (KNOB)	SELECT (KNOB)	EE	ED
START/STOP	STOP	EC	E8
AUTO	SINGLE	EB	E7
CONT	ROLL	EA	E6
PRINT	PRINT	E9	E5
NEXT	NEXT	C4	BD
PREV	PREV	C3	BC
HOME	HOME	C2	BB
UP-ARROW	UP-ARROW	C1	BA
DOWN-ARROW	DOWN-ARROW	C0	B9
LEFT-ARROW	LEFT-ARROW	BF	B8
RIGHT-ARROW	RIGHT ARROW	BE	B7
SETUP	SETUP	B0	AC
DSPL	DISPLAY	AF	AB
EDIT	CONFIG	AE	AA
UTIL	UTILITY	AD	A9
SELECT (up arrow)	UP	A6	A4
SELECT (down arrow)	DOWN	A5	A3

Table 2-10
Function Key Codes

Key Label	Unshifted	Shifted
F8	90	F6
F7	91	F5
F6	92	F4
F5	93	F3
F4	94	F2
F3	95	F1
F2	96	F0
F1	97	EF

Specifications

Table 2-11
Keyboard Performance Specifications
(for PRISM and TestLab keyboard)

Characteristic	Performance Requirement	Supplemental Information
Description		QWERTY typing keyset with HEX pad and function keys
Clock		19.2 kHz \pm 3%
Serial Data Protocol		19.2 Kbaud, synchronous One start bit, 8 data bits, one stop bit, no parity.
Programmable parameters		
Clock Rate		The number of degrees the knob is rotated before the keyboard signals the MPU that the knob has been turned.
Period		The time period over which the clicks are accumulated.
Mode		Forces keyboard into normal keyboard mode as opposed to knob mode.
Repeat Key Lag		0.5 s
Repeat Key Rate		10 per second
QWERTY Key Codes		See Table 2-12
Function Key Codes		Hexadecimal. See Table 2-13
Keypad Key Codes		Hexadecimal. See Table 2-14
Input Power		
DC Voltage	+5 V \pm 5%	Regulation occurs within the keyboard circuitry.
DC Current		1 A maximum

Table 2-12
Optional Keyboard Key Codes
(for PRISM and TestLab keyboard)

Key	Unshifted	Shifted	Control	Control-Shift	Caps Lock
BACKSPACE	08	08	08	08	08
TAB	09	D2	09	D2	09
RETURN	0D	0D	0D	0D	0D
ESC	1B	1B	1B	1B	1B
SPACE	20	20	20	20	20
'(apostrophe)	27	22	98	99	9A
, (comma)	2C	3C	9B	9C	2C
- (dash)	2D	5F	9D	1F	2D
. (period)	2E	3E	9E	9F	2E
/	2F	3F	A0	A1	2F
0	30	29	A2	29	30
1	31	21	A7	A8	31
2	32	40	B1	00	32
3	33	23	B2	B3	33
4	34	24	B4	B5	34
5	35	25	B6	C5	35
6	36	5E	C6	1E	36
7	37	26	C7	26	37
8	38	2A	C8	2A	38
9	39	28	C9	28	39
;	3B	3A	CA	CB	CC
=	3D	2B	CD	CE	3D
[5B	7B	CF	D0	D1
\	5C	60	F7	1C	5C
]	5D	7D	F8	1D	5D
A	61	41	01	01	41
B	62	42	02	02	42
C	63	43	03	03	43
D	64	44	04	04	44
E	65	45	05	05	45
F	66	46	06	06	46
G	67	47	07	07	47
H	68	48	08	08	48
I	69	49	09	09	49
J	6A	4A	0A	0A	4A
K	6B	4B	0B	0B	4B
L	6C	4C	0C	0C	4C
M	6D	4D	F9	FA	FB
N	6E	4E	0E	0E	4E

Specifications

**Table 2-12 (cont.)
Optional Keyboard Key Codes
(for PRISM and TestLab keyboard)**

Key	Unshifted	Shifted	Control	Control-Shift	Caps Lock
O	6F	4F	0F	0F	4F
P	70	50	10	10	50
Q	71	51	11	11	51
R	72	52	12	12	52
S	73	53	13	13	53
T	74	54	14	14	54
U	75	55	15	15	55
V	76	56	16	16	56
W	77	57	17	17	57
X	78	58	18	18	58
Y	79	59	19	19	59
Z	7A	5A	1A	1A	5A
	7C	7E	FC	FD	7C
RUBOUT (DEL)	7F	7F	7F	7F	7F
PRINT	E9	E5	E9	E5	E9

Table 2-13
Keyboard Function Key Codes

Key Label		Unshifted	Shifted	Control	Control-Shift
PRISM	TestLab				
F8	F8	90	F6	90	F6
F7	F7	91	F5	91	F5
F6	F6	92	F4	92	F4
F5	F5	93	F3	93	F3
F4	F4	94	F2	94	F2
F3	F3	95	F1	95	F1
F2	F2	96	F0	96	F0
F1	F1	97	EF	97	EF
SELECT (KNOB)	SELECT (KNOB)	EE	ED	EE	ED
START/STOP	STOP	EC	E8	EC	E8
AUTO	SINGLE	EB	E7	EB	E7
CONT	ROLL	EA	E6	EA	E6
PRINT SCREEN	PRINT SCREEN	E9	E5	E9	E5
NEXT	NEXT	C4	BD	C4	BD
PREV	PREV	C3	BC	C3	BC
HOME	HOME	C2	BB	C2	BB
UP-ARROW	UP-ARROW	C1	BA	C1	BA
DOWN-ARROW	DOWN-ARROW	C0	B9	C0	B9
LEFT-ARROW	LEFT-ARROW	BF	B8	BF	B8
RIGHT-ARROW	RIGHT ARROW	BE	B7	BE	B7
SETUP	SETUP	B0	AC	B0	AC
DSPL	DISPLAY	AF	AB	AF	AB
EDIT	CONFIG	AE	AA	AE	AA
UTIL	UTILITY	AD	A9	AD	A9
UP	UP	A6	A4	A6	A4
DOWN	DOWN	A5	A3	A5	A3

Specifications

Table 2-14
Keypad Key Codes (HEX)
(for PRISM and TestLab keyboards)

Key Label		Unshifted	Shifted	Control	Control-Shift
PRISM	TestLab				
0	0	80	D3	80	D3
1	1	81	D4	81	D4
2	2	82	D5	82	D5
3	3	83	D6	83	D6
4	4	84	D7	84	D7
5	5	85	D8	85	D8
6	6	86	D9	86	D9
7	7	87	DA	87	DA
8	8	88	DB	88	DB
9	9	89	DC	89	DC
A	m	8A	DD	8A	DD
B	μ	8B	DE	8B	DE
C	n	8C	DF	8C	DF
D	HELP	8D	E0	8D	E0
E	AUTOSET	8E	E1	8E	E1
F	HOME MENU	8F	E2	8F	E2
X	X	E3	E4	E3	E4
HELP NOTES	.	EE	ED	EE	ED

Table 2-15
Hard Disk Functional Specifications

Characteristic	Description
Description	2.5 in IDE hard drive, Winchester technology*
Formatted Capacity	64 Mbyte (TestLab standard/3001 option) 127 Mbyte (TestLab option)
I/O Transfer Rate	Up to 4.0 Megabits/second
Access Time	
Average Latency	8.7 ms
Seek Time (typical)	
Single Track	5 ms
Average	16 ms
Maximum	27 ms
Data Reliability	
Nonrecoverable Error	1 in 10 ¹³ bits read
Power Requirements	
+5 V Input	1.0 A for 3 seconds during spin up .42 A during seeking/read/write .23 A when idle

* Older mainframes may have a 20- or 40 Mbyte, ST506/412-family hard drive.

Table 2-16
CRT Monitor Functional Specifications

Characteristic	Description
Description	A 9 inch (diagonal) monochrome CRT monitor with P-31 phosphor.
Display Image Size	6.70 in X 5.00 in (17.17 cm X 12.82 cm)
Video Centering	Active video to be centered in physical center of CRT ± 0.125 inches
Video Input Signals	Std TTL level, white positive (See Figure 2-3)
DC Input Power	12.0 VDC ± 0.2 VDC
Input Current	1.5 A typical

Specifications

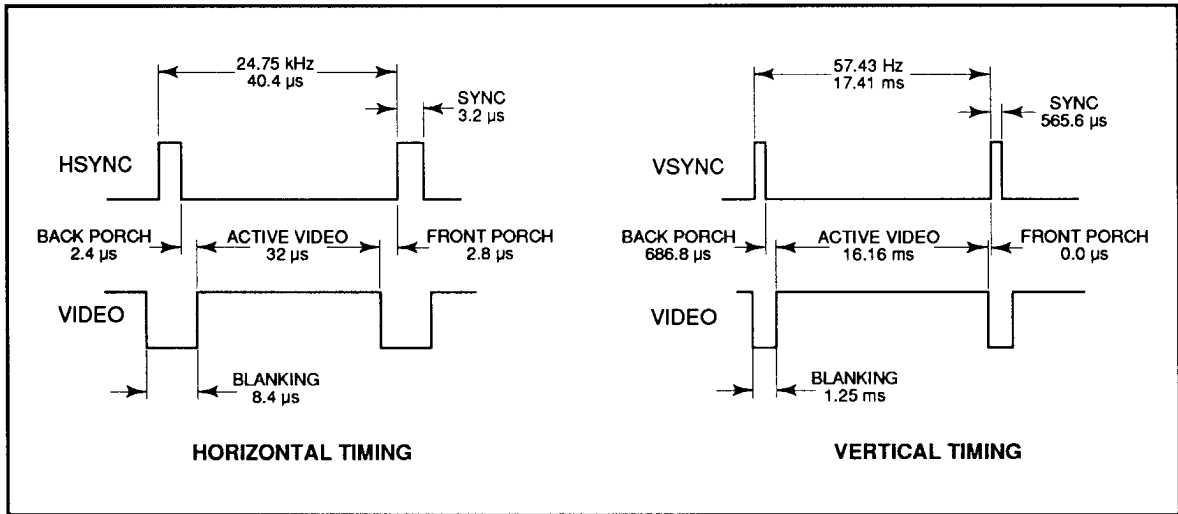

Figure 2-3. Video timing.

Section 3

CONNECTORS AND CABLING

This section describes the signal interconnections for the mainframe components and modules. Use this information to trace signal flow between the various electrical modules. References are made to the Signal Interconnect Diagrams in the *Diagrams* section as appropriate.

A description of interconnect signals is provided in *Section 13: Glossary of the MPU Board Service* manual.

CONNECTORS

Signal and connector information is provided as follows:

- MPU Assembly
- Power Supply and Power Distribution Board
- Application Module
- CRT Display Monitor
- Floppy Disk Drive
- Hard Disk Drive

MPU Assembly

The MPU assembly includes the MPU board, the Connector Adapter board (for CRT Monitor and internal TekLink signal routing) and the Keyboard Filter board.

Figure 3-1 shows the location of each connector on the MPU board, with the board viewed component side up. Note that the pin-numbering convention is provided for each MPU board connector. Refer to the Signal Interconnect Diagrams in Section 10 for detailed cabling information.

Connectors and Cabling

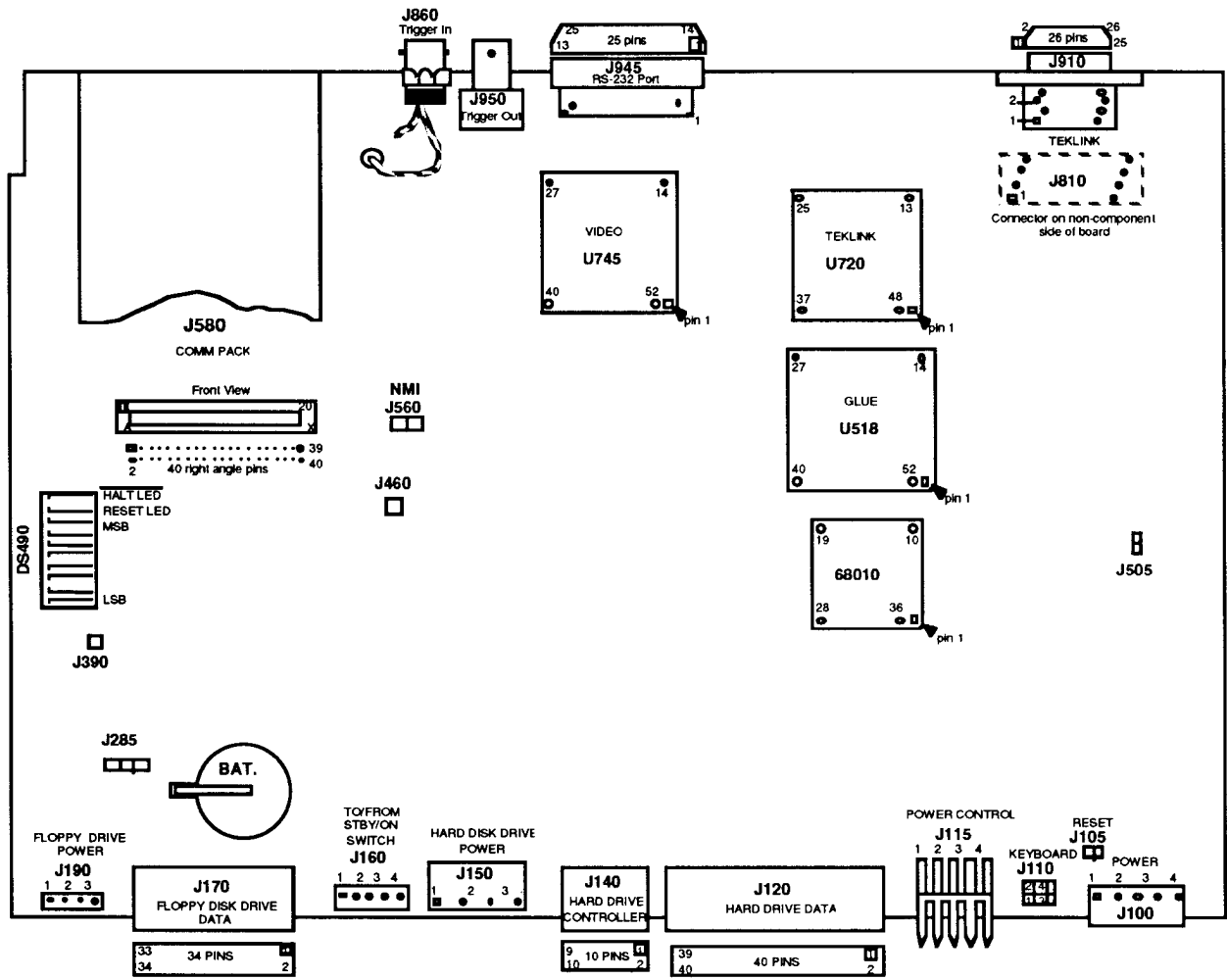

Figure 3-1. MPU connectors and pin keying.

Figure 3-2 shows the Connector Adapter board that connects to the back side of the MPU board. Connector pin assignments are as shown. A single wire from the MPU board provides +5 VDC at TP260. This voltage is used by arc suppression circuitry on the Connector Adapter board. Refer to the Signal Interconnect diagrams in Section 10 for detailed cabling information.

CAUTION

The interconnect pins between the MPU board and the Connector Adapter board are fragile and can be easily broken. Therefore, use care when removing the Connector Adapter board so as not to bend any interconnect pins.

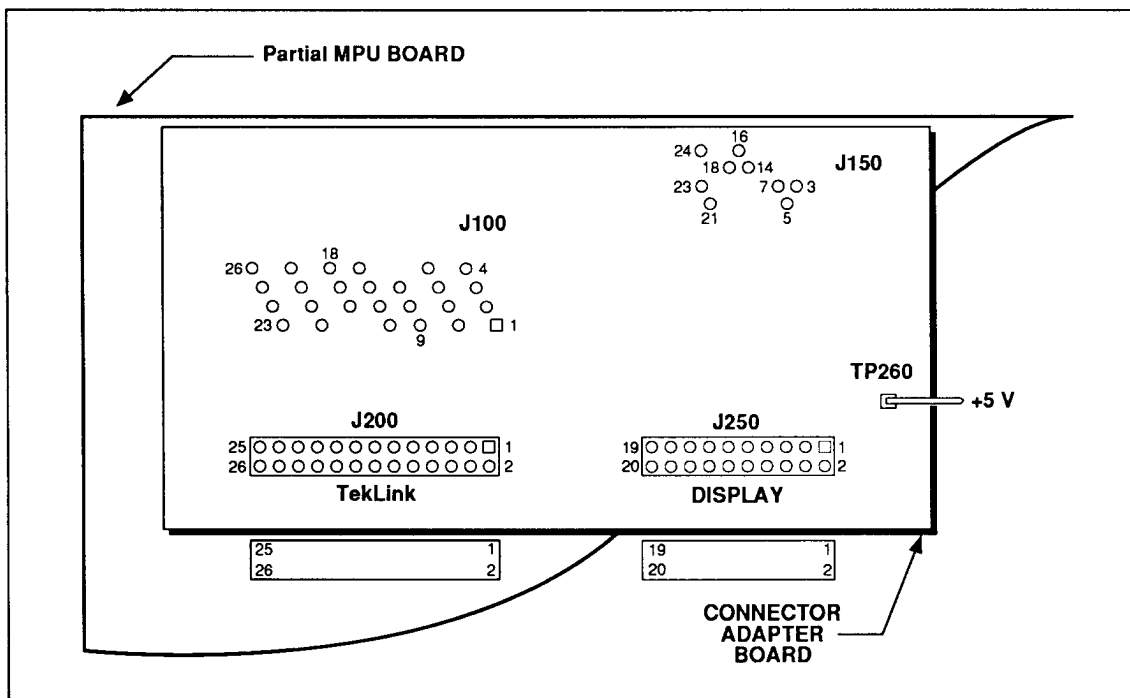

Figure 3-2. Connector Adapter board for the MPU board.

Connectors and Cabling

Figure 3-3 shows the connectors and pin configuration for the Keyboard Filter board. The Keyboard Filter board connects the Control Panel or the optional keyboard to the MPU board. If both the Control Panel and optional keyboard are installed, only the keyboard is energized. Refer to the Signal Interconnect diagrams in Section 10 for detailed cabling information.

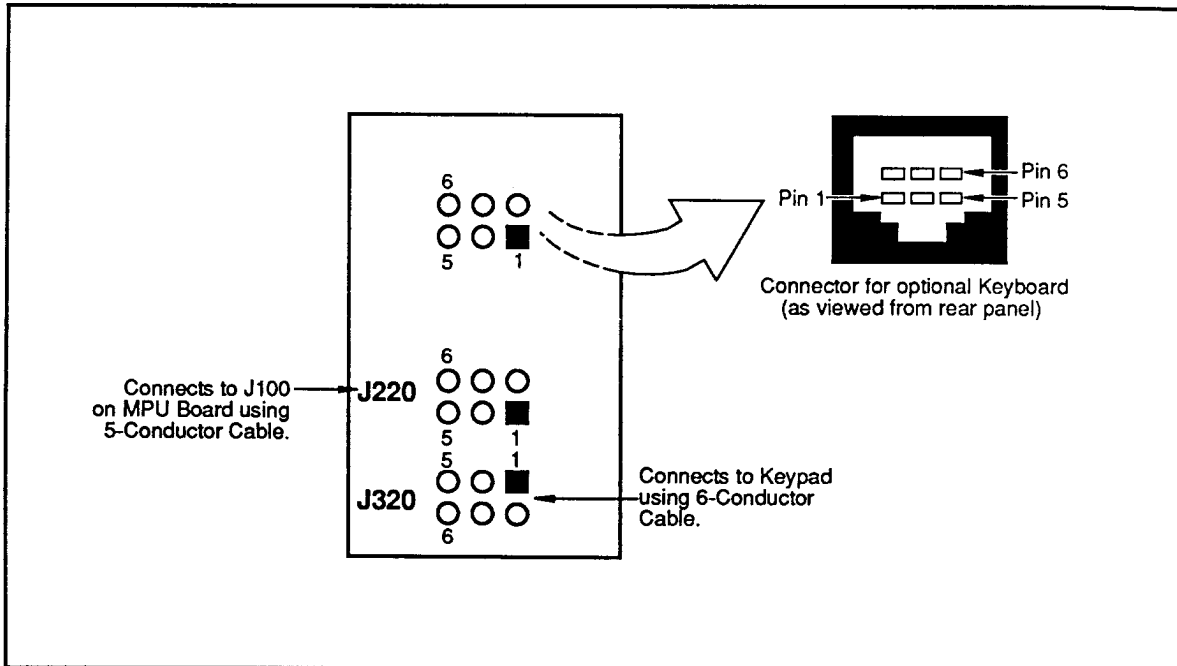

Figure 3-3. Keyboard Filter board connector and pin configuration (viewed from component side). Blow-up shows optional keyboard connector as viewed from rear.

Power Supply and Power Distribution Board

The Power Supply provides +5 VDC, +12 VDC, and -12 VDC to the MPU board and to the application module via the Power Distribution board. The Power Distribution board also routes power to the fan. Power for the Floppy Disk Drive, the Hex Keypad (or optional keyboard), and the CRT module is distributed by the MPU board.

The AC and DC Power Interconnect diagram in Section 10 shows the DC power distribution points on the Power Supply and Power Distribution boards. The Power Distribution board receives DC power from the Power Supply at J150. The Power Distribution board distributes DC power to the MPU board (J130), the application module (J530), and the fan (J540 or J550).

The AC and DC Power Interconnect diagram also shows how the AC line voltage is routed to chassis-mounted components for filtering, fusing, and 115/230 VAC line selection. It also shows the wiring for the STANDBY/ON switch and the REMOTE_ON_OFF signal from the MPU board.

Refer to other signal interconnect diagrams in Section 10 for additional power cabling information, such as, power distribution from the Power Interconnect board to the MPU board, and to various modules.

Power ON/OFF Control

WARNING

Line voltage is always present at the Power Distribution board even when the STANDBY/ON switch is set to STANDBY. Be sure to disconnect the power cord from the rear panel of the mainframe before servicing either the power supply or the Power Distribution board in order to avoid death or injury due to electrical shock.

The on/off state of the power supply is controlled by remote power control circuits on the MPU board and on the Power Distribution board. The power on/off signal path is from the STANDBY/ON switch to the MPU board, to the Power Distribution board, to the Power Supply. Refer to *Section 4: Theory of Operation*, for a detailed explanation of the power control circuits.

Refer to the Signal Interconnect diagrams in Section 10 for cabling information.

Application Module

Signal interconnect for the internal application module is via a TekLink cable connected to J200 on the Connector Adapter board. External application modules connect to J910, which is mounted directly to the MPU board.

NOTE

External application modules reside in an expansion mainframe.

An internal application module receives power from the power supply via the Power Distribution board. Refer to *Power Supply and Power Distribution Board* description earlier in this section for details regarding power distribution within the mainframe.

Refer to the Internal TekLink and Power Interconnect diagrams in Section 10 for detailed cabling information.

Connectors and Cabling

CRT Monitor

The CRT monitor circuit board connects to J250 on the Connector Adapter board mounted to the backside of the MPU board. This connector routes all control, video signals and power to the monitor's circuit board. Refer to the Display Signal Interconnect diagram in Section 10 for signal and connector pin assignments.

Floppy Disk Drive

The Floppy Disk Drive Signal Interconnect diagram in the Section 10 shows the interconnect cabling and connector pin assignments for the Floppy Disk Drive.

Hard Disk Drive

The Hard Drive Interconnect diagram in the *Diagrams* section shows the cabling and connector pin assignments for the control and data connectors (P1 and P2) and the cabling connector configuration for the power connector, P3.

Section 4

THEORY OF OPERATION

This section describes the electrical operation of the mainframe. The discussion goes from the general to the specific. These descriptions, together with the troubleshooting information in Section 8 and appropriate test equipment, will help you isolate a problem to the faulty module.

This section contains the following:

- *Logic Conventions* describe how logic functions are performed and represented in this manual.
- *Mainframe Component Descriptions* provides functional explanations of the major mainframe components.

Refer to *Module Description* in Section 1 for an overview of the mainframe components. Section 1 also provides an overview of the functional components associated with a mainframe.

NOTE

Service information for the MPU board and application modules is explained in separate service manuals.

LOGIC CONVENTIONS

Digital logic techniques are used to perform logic functions within electrical circuits. The functions and operations of the logic circuits are represented by standard logic symbols and terms. Logic functions are described using the positive logic convention. (Where voltages above the logic threshold voltage are the true, or 1 state, and the voltages below the threshold are the false, or 0 state.)

In logic descriptions, the logic true state voltages are referred to as high; whereas, the logic false states are referred to as low.

NOTE

The specific voltages that constitute a high or low state vary between families of electronic devices (e.g., ECL, CMOS, and TTL logic).

Active-low signals are indicated by either an (L), a slash (/), or a tilde (~) following the signal name. Signal names without indicators are considered to be either active-high or to have both active-high and active-low states.

MAINFRAME COMPONENT DESCRIPTIONS

The remainder of this section provides functional descriptions for each mainframe component. Components are described in the following order:

- Keyboard Filter board
- Keypad and Function Keys
- Optional Keyboard
- Keypad/Optional Keyboard Communications
- Connector Adapter board
- CRT Display Module
- Power Supply Module
- Power Distribution board
- Floppy Disk Drive
- Hard Disk Drive
- Hard Drive IDE Interface Board (IDE Interface Family)
- Hard Disk Controller Board (ST506/412 Interface Family)

Keyboard Filter Board

This small circuit board is mounted on the rear panel bracket of the MPU board assembly. It connects to the MPU board via a five-conductor cable. It serves two purposes:

1. It senses whether the optional keyboard is attached and selects the appropriate RS-232C communications path. See Figure 4-1.
2. It provides circuitry to reduce electro-magnetic interference associated with keyboard cabling.

The Keyboard/Control Panel "multiplexing" circuits function as follows: When no optional keyboard is connected, pin 1 of U235 is at +5 V, causing communication to occur between the MPU board and the Keypad. When an optional keyboard is connected, pin 1 of U235 is grounded causing communication to occur between the MPU board and the optional keyboard.

Power for the keypad and the optional keyboard is routed from the MPU board through the Keyboard Filter board. The optional keyboard may be connected or disconnected from the mainframe while power is applied without damage to either the keyboard or the MPU board.

Both the keypad and the optional keyboard communicate using RS-232C protocol. Tables 2-8 through 2-14 in *Section 2: Specifications* list the functional and performance characteristics for both the keypad and the optional keyboard.

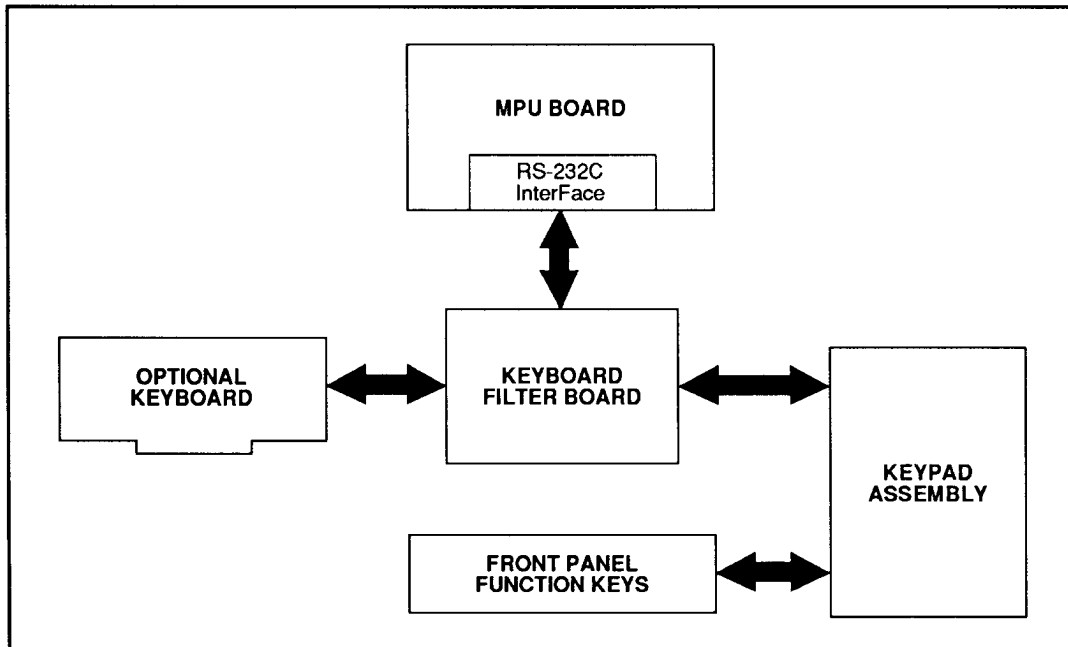

Figure 4-1. Keypad and optional keyboard communications block diagram.

Keypad

Refer to Figure 4-1.

The keypad consists of a keypad, cursor-control keys, special purpose keys, select keys, and a select knob. A row of eight special function keys are located directly under the below the CRT.

Theory of Operation

Refer to Section 10 for a signal interconnect diagram that shows the interconnect signal lines for the keypad, the function keys, and the optional keyboard.

Refer to the *Keypad/Optional Keyboard Communications* description later in this section for a description of communications protocol.

Refer to *Section 8: Troubleshooting*, for additional information about the keypad.

Optional Keyboard Module

Refer to Figure 4-1.

The optional keyboard includes a standard QWERTY typing keyset, a hexadecimal keypad, dedicated function keys, and a row of menu-dependent function keys. It also includes four cursor movement keys and a scroll knob.

The names of several keyboard keys are different for the PRISM and TestLab keyboards. Though some keycap names are different, the keycodes are identical for both keyboards.

The keyboard is connected to the mainframe by a shielded six-wire, coiled cable with a 6-pin, 2 X 3 Dupont Latch-n-Lock connector. Power to run the keyboard is distributed by the MPU board through the Keyboard Filter board. The keyboard interface circuitry is designed so that the keyboard may be connected or disconnected from the mainframe while power is applied without damage to either the keyboard or to the MPU board.

The Keyboard contains a power-on detection reset circuit.

Refer to Section 10 for an interconnect diagram that shows the interconnect signal lines for the keypad, the function keys, and the optional keyboard.

Refer to the *Keypad/Optional Keyboard Communications* description later in this section for a description of communications protocol.

Refer to *Section 8: Troubleshooting*, for additional information about the Optional Keyboard.

Keypad/Optional Keyboard Communications

Both the keypad and the optional keyboard communicate with the MPU board using TTL components and one half (channel A) of a UART. (Refer to Section 4 in the *671-0058-XX MPU Board Service* manual for a detailed description of the keyboard interface circuitry.) Communications is with either the keypad or the optional keyboard. The keypad is disabled when a keyboard is connected to the mainframe.

RS-232C communication with the MPU board is bi-directional. The sustained transfer rate is 19,200 baud. Both the keypad and the optional keyboard generate a clock frequency of 19.2 kHz \pm 3.0%. Either device is able to accept reprogramming of its programmable parameters (such as click rate, period, and operating mode) at any time.

The following is a brief description of communications to and from the MPU board.

To MPU Board

The serial data protocol is 19,200 baud, synchronous, with a sequence of one start bit, eight data bits, one stop bit and no parity.

The keypad or the optional keyboard sends the following information to the MPU board:

- Standard ASCII key codes for the QWERTY keyboard, function keys, hex key pad and dedicated function keys. If a key remains depressed more than 0.5 second, the QWERTY, hex key pad and cursor movement keys repeat at a rate of 10 characters per second, as long as the key remains pressed.
- A special notification byte to the MPU board indicating that the data transfer mode is about to change. This occurs whenever the user changes from using keys to using the knob, or vice versa. Valid values for key codes and knob values range from 0 to 250 to allow for command bytes.
- The knob value is sent to the MPU board as an 8-bit number. Bit 7 identifies the direction the knob is rotated. If bit 7 is set to one (logic high), then the knob is being rotated counterclockwise. If Bit 7 is set to zero (logic low), then the direction of rotation is clockwise.

From MPU Board

The data protocol is 19,200 baud synchronous with one start bit, eight data bits, one stop bit, and no parity.

The MPU board sends the following information to the keypad or the optional keyboard (this information is programmable depending on the user interface):

- A click rate. The click rate is a programmable parameter that the MPU board sends to the keypad or the optional keyboard. A click rate is the number of degrees the knob is rotated before the keypad or keyboard signals the MPU board that the knob has been turned. The click rate is the number of basic resolutions (tics) that make up each click. There are at least 100 tics (equal arcs) provided for one knob revolution.

NOTE

The size of a tic is a hardware constant and is not programmable.

- **Period.** The time period over which clicks are accumulated is a programmable parameter. The keypad or keyboard accumulates clicks over a period of time, then transmits the knob value to the MPU. The period of time can range from 8 ms to 40 ms, in 1 ms increments.
- **Mode Change.** Here, the MPU sends a command to the keypad or keyboard to force it into normal data mode, as opposed to knob mode.

Connector Adapter Board

The Connector Adapter circuit board is mounted to the backside of the MPU board and is used to connect data and control signal cables for the Display Driver board and the application module. The +5 VDC is used to bias arc-suppression diodes on the Connector Adapter board.

CRT Display Module

The CRT Display Module consists of a nine inch high-resolution monochrome CRT with a Display Driver board.

Figure 4-2 shows the circuitry and signal interconnections associated with the CRT module.

Video signals, VID0, VID1, VID2, VID3, HSYNC, and VSYNC, are generated by the Video Controller circuit on the MPU board. (Refer to Section 4 in the *MPU Board Service* manual for a detailed description of how the MPU board generates these display signals.) These signals, along with +12 VDC power are routed through the connector Adapter board (mounted on the back side of the MPU board) to the Video Driver board. The Video Driver board uses these signals to develop deflection and display voltages which drive the CRT. High voltage for the high voltage anode is also generated by the Video Driver board.

WARNING

Serious shock hazards exist on and around the CRT Monitor and the display circuit board. Refer all servicing to qualified service personnel.

Section 10: Diagrams, contains a Display Signal Interconnect diagram. This diagram shows the connector pin assignments for each interconnect signal.

Refer to *Section 8: Troubleshooting*, for additional troubleshooting information. This additional information can help you determine whether the CRT Display Module or other mainframe electrical modules are causing/contributing to a Display Monitor problem.

The Video Driver board provides adjustments for horizontal and vertical deflection as well as adjustments for brightness and focus. A back panel BRIGHTNESS control is also provided for user control of CRT intensity.

Power Supply Module

WARNING

Line voltage is always present at the Power Distribution board even when the STANDBY/ON switch is set to STANDBY. Be sure to disconnect the power cord from the rear panel of the mainframe before servicing either the power supply or the Power Distribution board in order to avoid death or injury due to electrical shock.

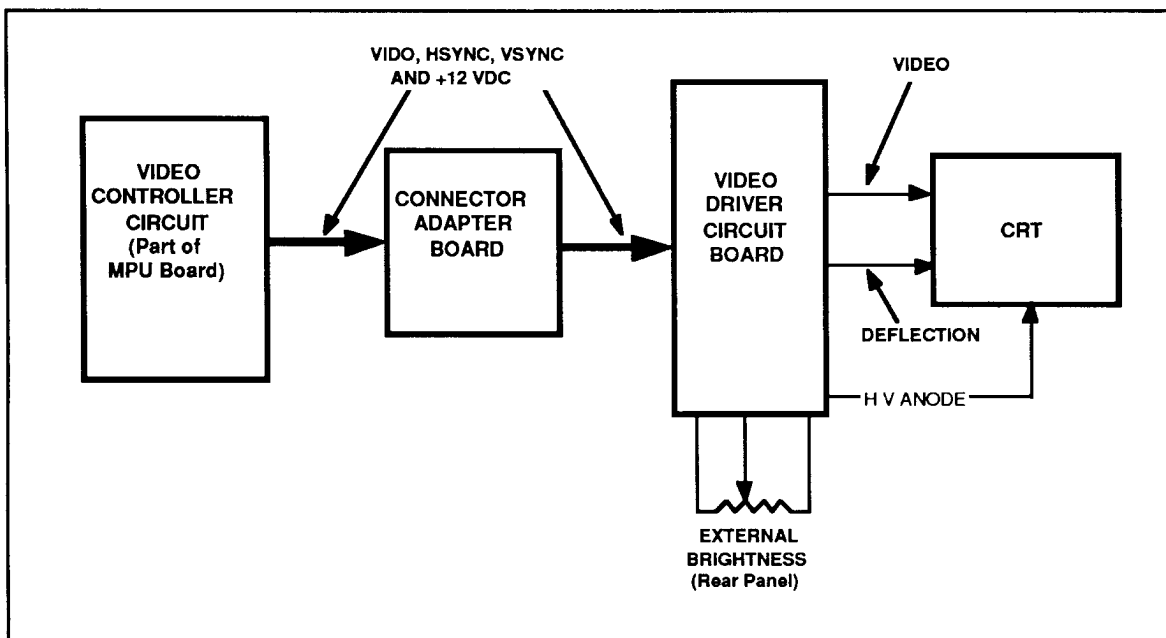

Figure 4-2. Video block diagram.

Theory of Operation

CAUTION

Do not attempt to operate the instrument from a 230 VAC voltage with the VOLTAGE SELECTOR switch (rear panel) in the 115 VAC position, or vice versa; otherwise, your power supply will be damaged.

General Description

The mainframe's power supply is a 140 watt switching supply that generates +5.0, +12 and -12 VDC voltages. The power on/off state and DC power distribution is done using the Power Distribution circuit board.

The power supply also has a +5 VDC current limit feature. In the event a current limit occurs, you must reset the supply by disconnecting and reconnecting the power cord.

Power Distribution

Figure 4-3 shows the basic AC and DC power distribution paths.

The Power Supply receives line voltage via "soft power on/off" circuitry on the Power Distribution board. The power supply is set for either 115 VAC or 230 VAC line voltage using the Line Voltage Selector switch on the rear panel of the mainframe.

The MPU board, application module, and fan receive power from the supply via the Power Distribution board. The + 5 VDC to the MPU board and the +12 VDC to the MPU board and fan(s) are fused at 5 A on the Power Distribution circuit board. Power Distribution paths are shown in detail by the Power Supply Interconnect drawings in Section 10.

All other mainframe modules receive power from the supply distributed by the MPU board. Refer to the *MPU Board Service* manual for DC power fuses that are located on the MPU board.

Refer to the following description of the Power Distribution Circuit Board for additional information on Power Supply operation.

Power Distribution Circuit Board

The Power distribution Circuit board serves two functions:

1. It provides "soft power" on/off control for the power supply.
2. It distributes AC and DC power.

Soft Power Control

Refer to Figure 4-3, which shows circuitry and interconnections associated with power supply operation. As needed, refer to the Power Distribution Board Schematic in the *Diagrams* section. Note that the AC line voltage must pass through a relay before it can be applied to the Power Supply. This relay is controlled by soft start circuitry on the MPU and Power Distribution boards as follows:

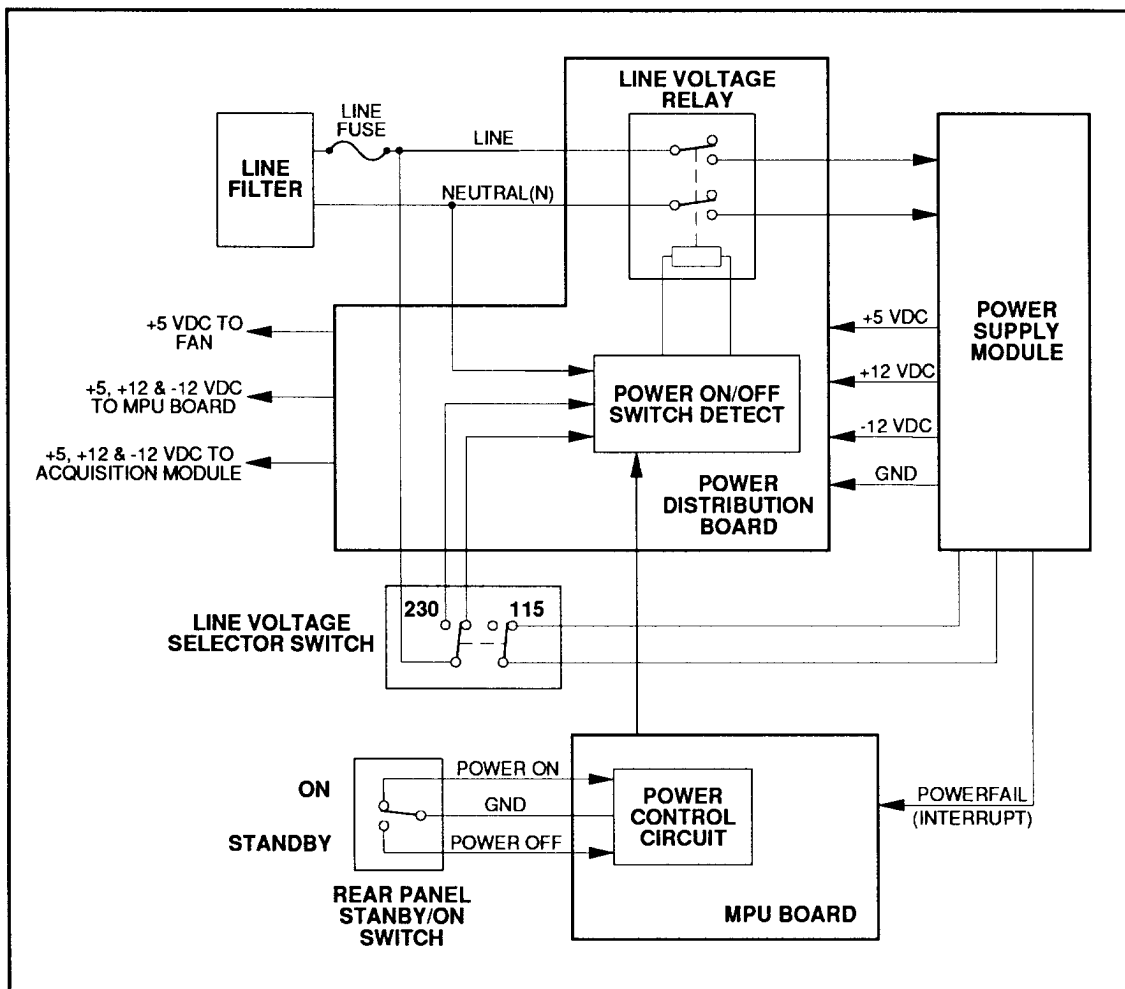

Figure 4-3. Power Supply control circuitry.

Theory of Operation

Line voltage is present at the Power Distribution board whenever the power cord is connected to the line voltage. This AC voltage is used to provide power to a small DC supply on the Power Distribution board. This keeps the AC Line Relay (also part of the Power Distribution board) open, thus keeping line voltage from the Power Supply module.

When the STANDBY/ON switch is set to ON, the POWER ON line to the MPU board is grounded. This in turn causes REMOTE_ON_OFF to be set to ground potential. A grounded REMOTE_ON_OFF line causes a transistor in the Power On Switcher supply to turn off, thus closing the AC Line Relay and routing AC line voltage to the Power Supply module. The DC voltages are routed to mainframe modules via the Power Distribution board.

The Power Supply is turned off when the rear panel STANDBY/ON switch is set to STANDBY. After a designated time, determined by the MPU board power control circuit, the REMOTE_ON_OFF signal line goes high. The Power On Switcher transistor is turned on, opening the line voltage path to the Power Supply module.

Floppy Disk Drive

The Floppy Disk Drive is a 3.5 inch, micro-floppy disk drive that has a storage capacity of 1 Mbyte unformatted data and 720 Kbyte formatted. It uses diskettes prepared according to ANSI X3B8 draft, double-sided, 135 TPI, and certified up to track 79.

The unit is connected to the MPU board using two cables: a 34-conductor ribbon cable for data input/output and a 4-conductor ribbon cable for power input.

HARD DISK DRIVE

There are various hard drives, of different sizes and vendors, used in PRISM and TestLab mainframes. These hard drives can be grouped into two families: the IDE interface drives and the ST506/412 interface drives. (Current PRISM and TestLab mainframes use the IDE interface drives; older models use the ST506/412 drives.)

Diagnostics may be used to isolate a failed hard drive module. The hard drive can then be replaced as a unit.

HARD DRIVE IDE INTERFACE BOARD (IDE INTERFACE FAMILY)

The IDE Interface board contains the circuitry to interface the hard drive to the MPU circuit board.

NOTE

The MPU board has been modified several times. To ensure compatibility with the IDE-interface hard drive, the Tektronix part number of the MPU board in your mainframe must be 671-0058-04 or greater.

The 16V8 integrated circuit performs the following functions:

- Determines which chip select line of the hard drive to use with the given command
- Decodes the R/W (read/write) line into the appropriate IOR or IOW line needed for the hard drive
- Generates the needed BTACK signal for the MPU 68010

Together, address line BBA4 and the signal _HDC determine which chip select line of the IDE drive to activate. If BBA4 and _HDC are both low, then CS0 is active low. If BBA4 is high when _HDC is low, then CS1 is active low.

Signals _HDC, _BBLDS, and BBRW are decoded to determine whether the activity is to read from (_IOR) or write to (_IOW) the hard drive. In either case, both _HDC and _BBLDS must be active low. If BBRW is high, a read operation is performed; if BBRW is low, a write operation is performed.

BTACK is generated by the 16V8 integrated circuit. BTACK is asserted at the time of the second positive edge of the B10MHZ clock after _HDC changes to an active low. The BTACK signal is then sent back to the 68010 microprocessor, signaling permission to complete the data transfer.

The 16V8 integrated circuit is also used to invert the IDE hard drive interrupt signal, making the signal compatible with the MPU hardware interrupt handling circuitry.

HARD DISK CONTROLLER BOARD (ST506/412 INTERFACE FAMILY)

The Hard Disk Controller manages the transfer of data between the MPU board and the Hard Disk Drive. It consists of functional circuitry as shown in Figure 4-4. The three basic functional areas are:

- **WD2010 Hard Disk Controller.** The Western Digital WD2010-05 Hard Disk Controller/Formatter is the central component on the board. It manages data transfer between the Hard Disk Drive and the MPU board.

Theory of Operation

- **MPU Board Interface.** The MPU side of the WD2010 consists of decode and timing PALS, RAM, and several read/write control circuits.
- **Hard Disk Drive Interface.** The Hard Disk Interface side of the WD2010 includes the write and read control line buffers, a write compensator, and a data (read) separator.

The basic operation of the hard disk controller is as follows:

The Hard Disk Controller is a memory-mapped I/O device that uses the MPU board's buffered data bus, BD [00-15], to read and write data to/from the WD2010 and/or the sector RAM. The sector RAM consists of a static RAM and address counter. Since the WD2010 makes the bus active when accessing the sector RAM, data bus transceivers are used to isolate the MPU during this time.

Whenever the WD2010 is not using the sector RAM, it turns control of the sector RAM and data bus over to the MPU. This causes the decode and timing PALS to deselect the sector RAM and switch the data transceivers.

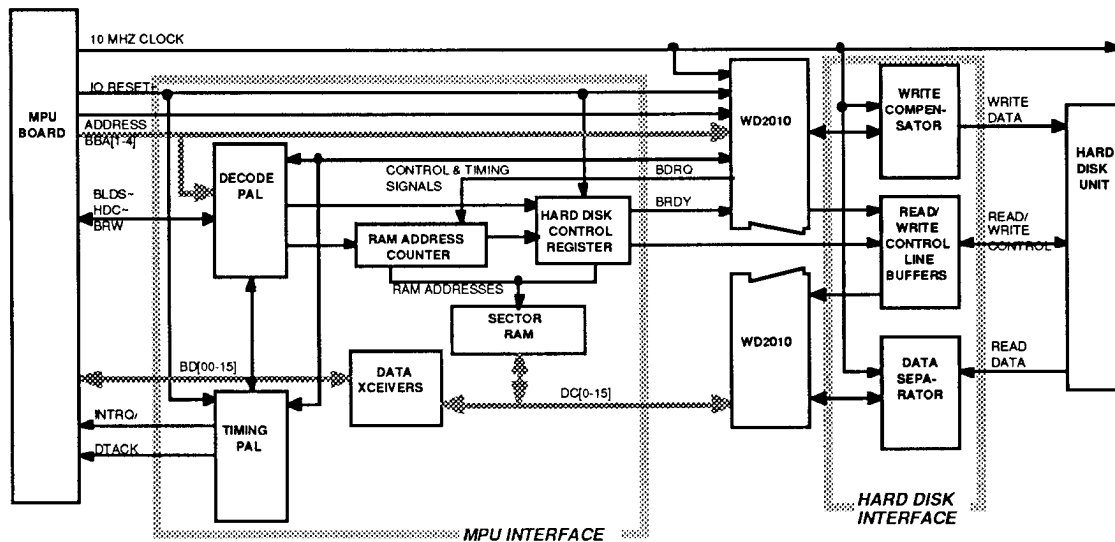

Figure 4-4. Hard Disk Controller basic block diagram.

When the MPU wants to access the sector RAM it sets BBA 1, 2, and 3 to 0 (logic low). The timing PAL then asserts timing and control signals corresponding to the requested read, write, or format command as explained in the following paragraphs.

During write sector commands, the MPU sets up task-related instructions in a "Task File" within the WD2010. The MPU then asserts a write sector command and the WD2010 asserts BCR/. This causes control signals from the decode PAL to zero the RAM address counter. The WD2010 then generates a status byte to inform the MPU that it can load the sector RAM with the data to be written.

When the RAM address counter reaches its maximum count, it asserts BRDY, informing the WD2010 that the sector RAM is full. The WD2010 then asserts BCS/ causing the MPU bus to be disconnected from the data transceivers. The WD2010 outputs read or write control signals to allow it access to the sector RAM. When the WD2010 is done using the sector RAM, it removes BCS/, again allowing the MPU to access the dc [0-15] bus.

The read sector command operates in a manner similar to write sector, except that the sector RAM is loaded by the WD2010 instead of the MPU.

Theory of Operation

- **MPU Board Interface.** The MPU side of the WD2010 consists of decode and timing PALS, RAM, and several read/write control circuits.
- **Hard Disk Drive Interface.** The Hard Disk Interface side of the WD2010 includes the write and read control line buffers, a write compensator, and a data (read) separator.

The basic operation of the hard disk controller is as follows:

The Hard Disk Controller is a memory-mapped I/O device that uses the MPU board's buffered data bus, BD [00-15], to read and write data to/from the WD2010 and/or the sector RAM. The sector RAM consists of a static RAM and address counter. Since the WD2010 makes the bus active when accessing the sector RAM, data bus transceivers are used to isolate the MPU during this time.

Whenever the WD2010 is not using the sector RAM, it turns control of the sector RAM and data bus over to the MPU. This causes the decode and timing PALS to deselect the sector RAM and switch the data transceivers.

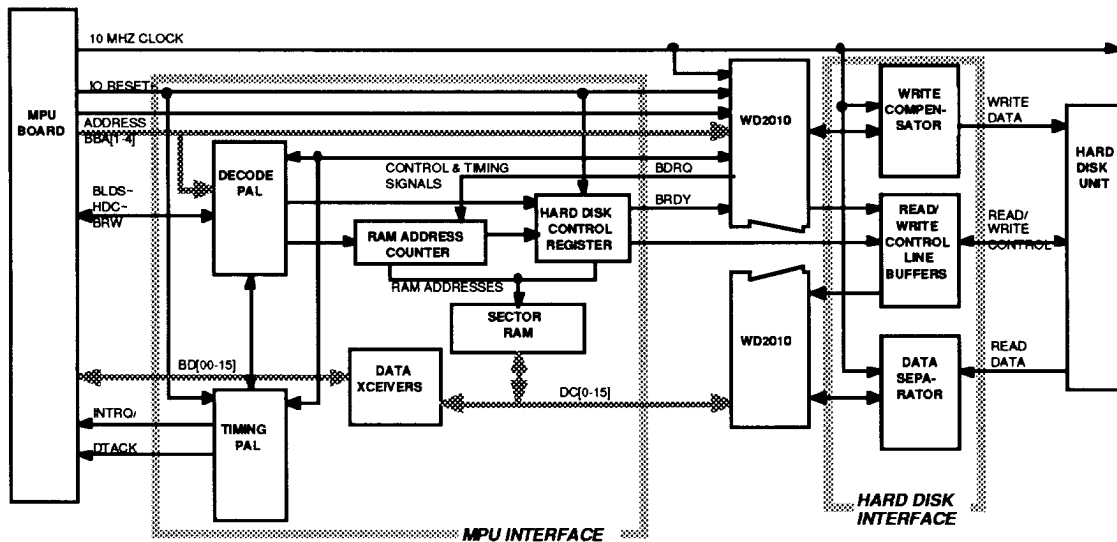

Figure 4-7. Hard Disk Controller basic block diagram.

When the MPU wants to access the sector RAM it sets BBA 1, 2, and 3 to 0 (logic low). The timing PAL then asserts timing and control signals corresponding to the requested read, write, or format command as explained in the following paragraphs.

During write sector commands, the MPU sets up task-related instructions in a "Task File" within the WD2010. The MPU then asserts a write sector command and the WD2010 asserts BCR/. This causes control signals from the decode PAL to zero the RAM address counter. The WD2010 then generates a status byte to inform the MPU that it can load the sector RAM with the data to be written.

When the RAM address counter reaches its maximum count, it asserts BRDY, informing the WD2010 that the sector RAM is full. The WD2010 then asserts BCS/ causing the MPU bus to be disconnected from the data transceivers. The WD2010 outputs read or write control signals to allow it access to the sector RAM. When the WD2010 is done using the sector RAM, it removes BCS/, again allowing the MPU to access the dc [0-15] bus.

The read sector command operates in a manner similar to write sector, except that the sector RAM is loaded by the WD2010 instead of the MPU.

Section 5

VERIFICATION AND ADJUSTMENT PROCEDURES

This section contains three parts: Functional Check Procedures, Performance Verification Procedures, and Adjustment Procedures. This information allows a qualified service technician to verify module operation and to perform selected module adjustments.

NOTE

The verification procedures in this manual do not provide a detailed verification for the MPU board and application module. Refer to their respective service manuals for related procedures.

The following provides a brief definition for each type of procedure:

- **Functional Check Procedure.** These procedures may be used as an incoming inspection to verify that a mainframe system is functioning properly.
- **Performance Verification Procedures.** These procedures provide a detailed check of the product specifications. Specifications listed in the performance requirements column of Specifications, Section 2, can be verified using these procedures. Under normal circumstances, the Functionality Checks within these Procedures provide an adequate test of product performance.
- **Adjustment Procedures.** These procedures describe how to adjust the selected mainframe modules to meet module specifications. If the Module cannot be adjusted to meet product specifications, then repair is necessary.

REQUIRED TEST EQUIPMENT

Table 5-1 shows the test equipment required to perform the procedures listed in this section. Specifications given for the test equipment are the minimum necessary for accurate verification and adjustment of this module. All test equipment must be accurately calibrated and operating within the given specifications. If equipment is substituted, it must meet or exceed the specifications of the recommended equipment.

Verification and Adjustment Procedures

Table 5-1
Required Test Equipment

Equipment	Specification	Equivalent Instrument
Oscilloscope, 2 channel	350 MHz bandwidth	Tektronix 2467 or equivalent
Probes, oscilloscope (2 ea)	10X, 350 MHz, 1.3 m long	Tektronix P6136
Digital multimeter	4½ digits, 0.1% DC accuracy	Tektronix DM 504A or equivalent
Frequency counter	1 part in 10 ⁶ accuracy	Tektronix DC 5010 or equivalent
Power module mainframe		Tektronix TM 5003 or TM 5006A
TekLink output test adapter		Tektronix part number 174-2829-00
System diagnostic disk		Tektronix part number 063-0165-XX (PRISM 3001) 062-9925-XX (2505 TestLab)

OPERATING A MAINFRAME IN THE SERVICE POSITION

In most cases, you must place the MPU board and application module in a "servicing position" to perform troubleshooting and servicing functions. You need to observe specific guidelines when operating an MPU board and/or application module in the service position. Refer to *Physical Placement of Modules for Troubleshooting* in Section 6 for instructions on how to place these modules in a service position.

WARNING

After removing the mainframe cover, the cooling fan blades are not completely shielded. Guard against injury by keeping fingers and loose objects away from the moving blades when operating the instrument in the service position.

CAUTION

When operating a mainframe in the service position, the fans do not provide adequate cooling for any installed /connected application module. To provide adequate cooling and to prevent damage due to excessive heat, raise the mainframe at least one half inch off the work surface, then position another fan to blow air across the application module.

FUNCTIONAL CHECK PROCEDURES

When powering on the mainframe, the system software automatically performs functional checks on the compute kernel hardware of the MPU board. For additional functional testing, use the System Diagnostic Disk.

NOTE

The diagnostics described above verifies the operation of the MPU board, hex keypad (or optional keyboard), floppy disk drive, and CRT display module. Application modules are not verified during the power-on sequence. Refer to applicable application module service manuals for descriptions of related diagnostic tests.

Refer to the *MPU Board Service* manual for a detailed description of how to verify your system using System Diagnostic Software.

TestLab Functional Verification Using System Diagnostics

Power-on diagnostics automatically perform a functional check on the compute kernel hardware of the MPU board. If you insert the diagnostic disk into the floppy disk drive prior to powering on the mainframe, additional functional tests are performed during the power-on sequence. The 2505 TestLab must pass all these diagnostics tests.

Complete the following to check that all the diagnostic tests pass.

1. Ensure the rear panel STANDBY/ON switch is in the STANDBY position.
2. Ensure the mainframe has completed the power-off sequence, then remove the COMM pack from the COMM Pack port at the rear of the mainframe.
3. Insert the diagnostic disk (Tektronix part number 062-9925-XX) into the floppy disk drive.
4. Power on the mainframe; check that all kernel diagnostic tests pass, and that the system starts to load additional software from the floppy disk drive.
5. The diagnostic software automatically performs additional tests on the system hardware and mainframe peripheral modules. Check that all tests pass.
6. To verify keyboard operation, select M Keyboard in the Area field. Optionally, move the cursor to the Area field and select M Keyboard and perform a manual check of the keyboard.
7. The diagnostic software continues to perform additional tests on the application module installed in the TestLab mainframe. Check that all tests pass. If desired, you can control these tests by pushing F6: Run All on the keyboard.

PERFORMANCE VERIFICATION PROCEDURES

Performance verification procedures check specifications listed in the performance requirements column of the Specifications section. (Items listed in the performance requirements columns are specifications that a mainframe must meet.) If verification of the listed electrical specifications is required for incoming inspection or other purposes, perform the appropriate procedures outlined in this part of the Verification and Adjustment section.

SCLK TekLink Clock Check

The TekLink system clock (SCLK) is used as the master clock in the time base sampling circuitry on the TestLab acquisition modules.

Table 5-2
TekLink Clock Frequency Specification

Characteristic	Performance Requirements	Supplemental Information
TekLink Clock (SCLK) Frequency	12.5 MHz \pm 0.005%	

Use a frequency counter and the special TekLink Output test adapter (Tektronix part number 174-2829-00) to check the frequency of the TekLink Clock (SCLK).

1. Set the trigger threshold level of the frequency counter for a TTL level (\pm 1.3 VDC).
2. Connect TekLink Output test adapter to the TekLink connector on the rear panel and to the frequency counter.
3. Power on the mainframe.
4. Verify that the measured frequency is 12.500 MHz \pm 625 Hz.
5. Disconnect the TekLink Output test adapter from the mainframe and from the frequency counter.

DC Voltage Power Supply Checks

The MPU board receives +5 VDC, +12 VDC, and -12 VDC from the power supply module to power the electronic circuitry. Voltage and ripple levels can be checked at test points on the MPU board.

Use a DMM and oscilloscope to check the DC voltages at the MPU board test points shown in Figure 5-1.

1. Set the DMM, or oscilloscope CH 1 Vertical Input, to 20 V and verify voltages according to the specifications listed in Table 5-3.

Table 5-3
Power Supply Tolerances

Power Supply	Voltage		Ripple
	Minimum	Maximum	
+5 V	+4.875	+5.025	100 mV p-p
+12 V	+11.4	+12.6	100 mV p-p
-12 V	-12.6	-11.4	100 mV p-p

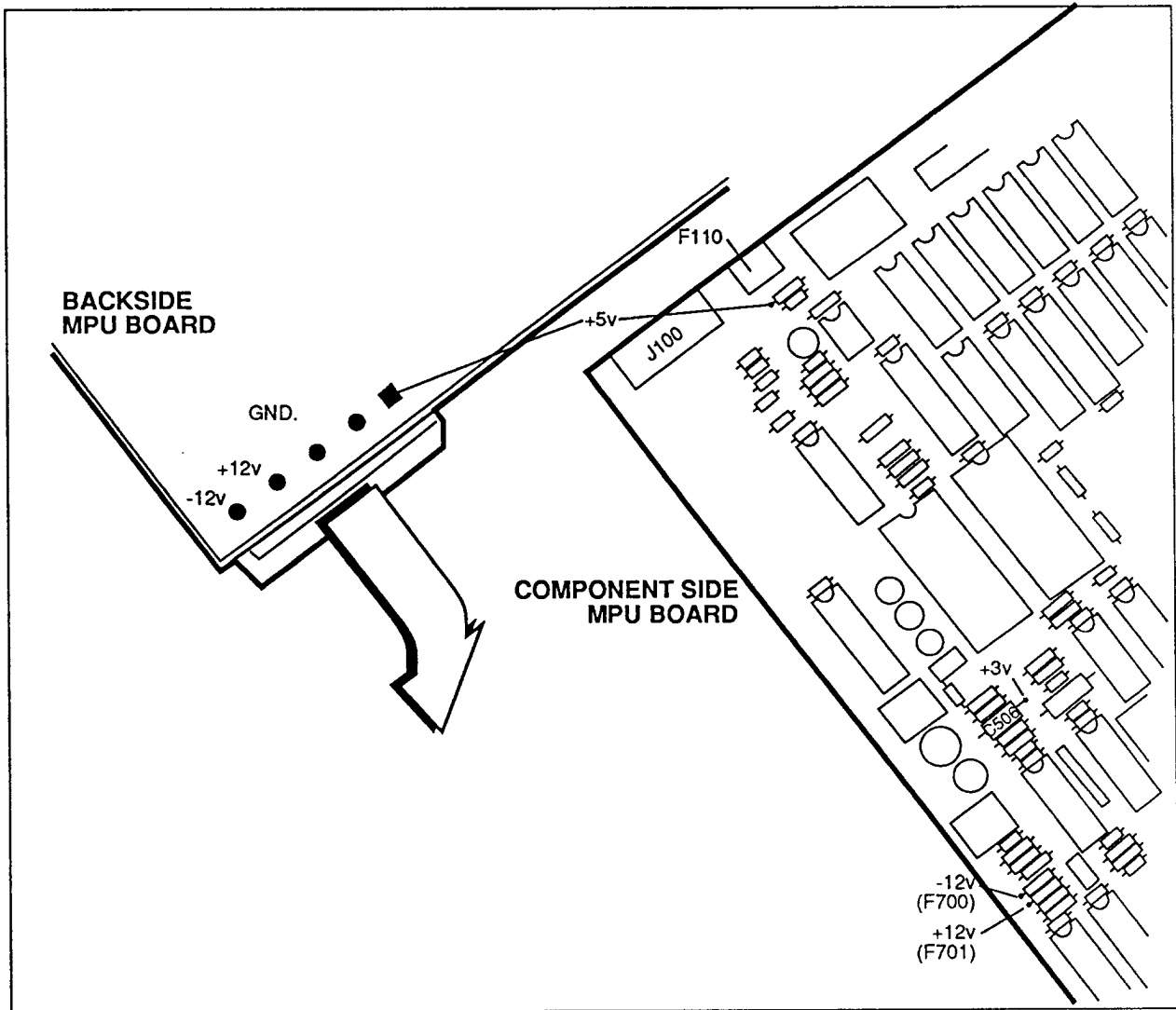

Figure 5-1. Power Supply test points on MPU board.

Verification and Adjustment Procedures

2. Check voltage ripple (noise) specification in the following manner:
 - a. Connect a 10X probe to the oscilloscope Channel 1 input connector and to the +5 V test point on the MPU board.
 - b. Connect a second 10X probe to the oscilloscope Channel 2 input connector and ground (metal strip down center of MPU board).
 - c. Connect the probe ground clips together.
 - d. Set the oscilloscope controls as follows:

Sweep Speed	5 ms/division
Volts	0.2 V/division
Coupling	
CH 1	AC
CH 2	AC
CH 2	
Invert	ON
Add Mode	ON
Bandwidth Limiter	ON
Triggering	
Source	Line
Slope	+ (plus)
Mode	Automatic
Coupling	AC

- e. Check +5 V for an oscilloscope display within the ripple limits listed in Table 5-3.
- f. Repeat step e for +12 V and -12 V.
- g. Disconnect the oscilloscope.

ADJUSTMENT PROCEDURES

The MPU board and CRT Monitor contain adjustments. The MPU board has its own service manual that describes how to adjust its circuits. Refer to the following for instructions on how to adjust the CRT Monitor.

The Monitor contains adjustments a qualified technician can use to adjust the display image. Figure 5-2 shows how an "optimum" image is positioned on the CRT. This image area should be centered both horizontally and vertically on the display screen and be at optimum focus and brightness/contrast.

The following hand tools are required to perform the CRT monitor adjustments:

- $\frac{3}{32}$ -inch slotted adjustment tool (non-magnetic)
- $\frac{3}{32}$ -hex adjustment tool (non-magnetic)
- magnetic screwdriver ($\frac{1}{4}$ -inch drive)
- POZIDRIV-type bit #2

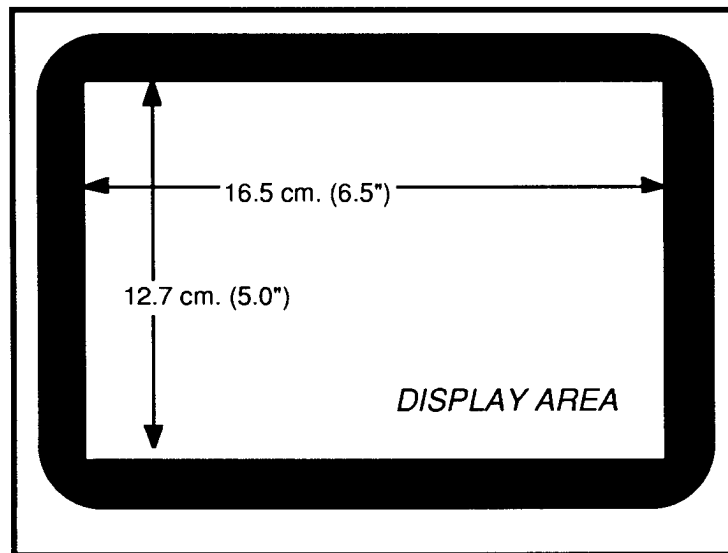

Figure 5-2. Optimum size and positioning for display area.

Verification and Adjustment Procedures

Be sure to observe the following warnings before and during any service work to, or in the area of, the CRT.

WARNING

Serious shock hazards exist within the mainframe when the cover panel is removed. Do not remove the mainframe cover unless qualified to do so.

WARNING

CRTs RETAIN HAZARDOUS VOLTAGES FOR LONG PERIODS OF TIME AFTER POWER DOWN. The CRT should be serviced only by qualified personnel familiar with CRT servicing procedures and precautions.

WARNING

TO AVOID SERIOUS SHOCK HAZARD, BEFORE ATTEMPTING ANY WORK ON THE CRT, discharge the CRT by simultaneously shorting the anode connection to chassis ground using a plastic-handle screwdriver. When discharging the CRT, place the metal blade of the screwdriver against the chassis, then slip the screwdriver tip under the CRT anode cup.

WARNING

USE EXTREME CARE WHEN HANDLING THE CRT. Rough handling may cause it to violently implode. Do not nick or scratch the glass, or subject it to undue pressures during removal or installation. When handling the CRT, wear safety goggles and heavy gloves for protection.

WARNING

If the DAG spring is not present to ground the CRT, hazardous voltages may exist on the outside of the CRT. The CRT anode forms a capacitor with the external CRT DAG coating. Always replace the DAG ground spring before powering up the instrument.

Equipment Set-up

Perform the following to prepare the mainframe for CRT Monitor adjustments.

NOTE

The displayed image can be affected by the orientation of the mainframe to the earth's gravitational pull. Thus, a CRT adjusted in one location may need re-alignment when repositioned or moved to another location.

1. Set the STANDBY/ON switch to STANDBY, and disconnect the line voltage power cord from the rear panel.
2. Remove the mainframe cover as described in the cover removal procedure in Section 6.
3. Remove the power cable from the installed application module to eliminate the need for an additional cooling fan.
4. Position the mainframe so that the horizontal axis (left-to-right) of the CRT is parallel with the earth's gravitational pull (North-to-South).
5. Re-attach the line voltage power cord, and set the STANDBY/ON switch to ON.

CRT Adjustments

Allow the mainframe to warm up at least 20 minutes before making any adjustment. Reference Figures 5-3 and 5-4 as necessary. Use non-magnetic adjustment tools when performing any of the following adjustments.

1. If necessary, adjust VERTICAL HOLD for a stable display.
2. Adjust brightness of displayed image as follows:
 - a. Set the rear panel BRIGHTNESS control full on (all the way clockwise).
 - b. Set the Display Driver board BRIGHTNESS control to a point where the horizontal raster lines are just visible.
 - c. Adjust rear panel BRIGHTNESS for optimum viewing.
3. Adjust FOCUS for optimum character focus over entire display image.

NOTE

Check focus at center and at each corner of the display. Set FOCUS control to achieve best over-all focus for entire display image.

Verification and Adjustment Procedures

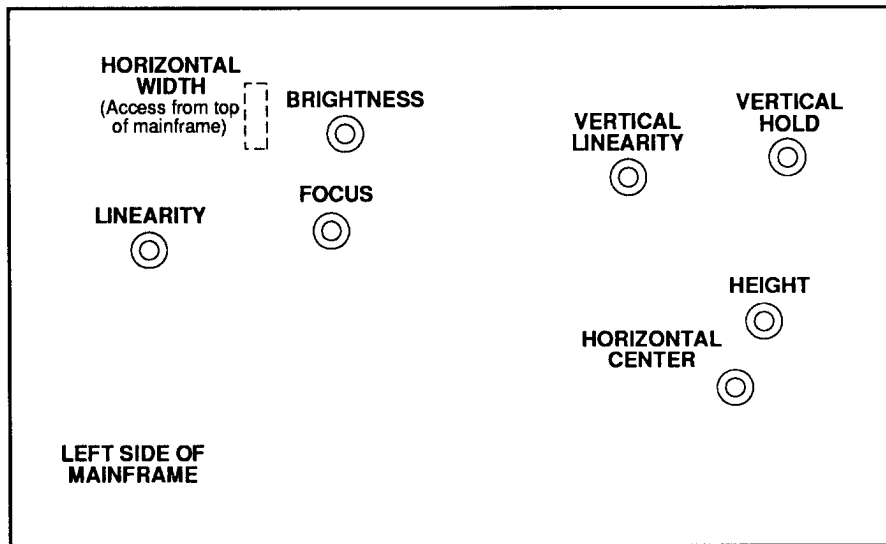

Figure 5-3. CRT display adjustment locations.

4. Check character height and line spacing at top and bottom of the display area. Adjust **VERTICAL LINEARITY** to obtain the same character size and line spacing at top and bottom of the display image.
5. Check character width and spacing at left and right edges of display area. Adjust **LINEARITY** to obtain same character width and spacing at left and right edges of the display area.
6. Obtain display test pattern as follows:
 - a. Insert the system diagnostic disk and load the diagnostics software.
 - b. Obtain Diagnostics menu and move cursor to **AREA** field.
 - c. Select **M** (manual) Display area and then move cursor to **ROUTINE** field.
 - d. Press function key **F2** to initiate Display test.
 - e. Press any key until the highlighted rectangular test pattern is displayed.
7. Adjust **HEIGHT** of test pattern for 5.0 inches (12.7 cm).
8. Adjust **HORIZONTAL WIDTH** of test pattern for 6.5 inches (16.5 cm).

9. Adjust vertical centering as follows:

NOTE

To adjust vertical centering, you must first remove the top of the CRT shield. If vertical centering is not objectionable (even though the test pattern may not be centered exactly), skip to Step 10. Otherwise proceed with the following to adjust vertical centering.

- a. Turn power off, and remove the line cord.
 - b. Remove the top of the CRT shield using procedures provided in Section 6 (Video Control board disassembly/assembly procedure).
 - c. Perform Steps 4-6 of *Equipment Set-up Procedure*.
 - d. Adjust Vertical Centering Ring-Tab on CRT deflection yoke (see Figure 5-4) to center test pattern vertically on display screen.
10. Adjust HORIZONTAL CENTER to center test pattern horizontally on display screen.
 11. If test pattern cannot be centered as described in Steps 9 and 10, adjust the Diagonal Positioning Ring-Tab (Figure 5-4) and repeat Steps 9 and 10.

NOTE

Steps 9, 10, and 11 interact. Therefore, you may have to perform this sequence several times to obtain optimum centering of the test pattern on the display screen.

12. This completes the CRT adjustment procedures. Perform the following:
 - a. Turn power off
 - b. Remove line cord
 - c. Reconnect the power connector for the application module
 - c. Install CRT shield (if removed)
 - d. Install mainframe cover

Your mainframe is now ready for use.

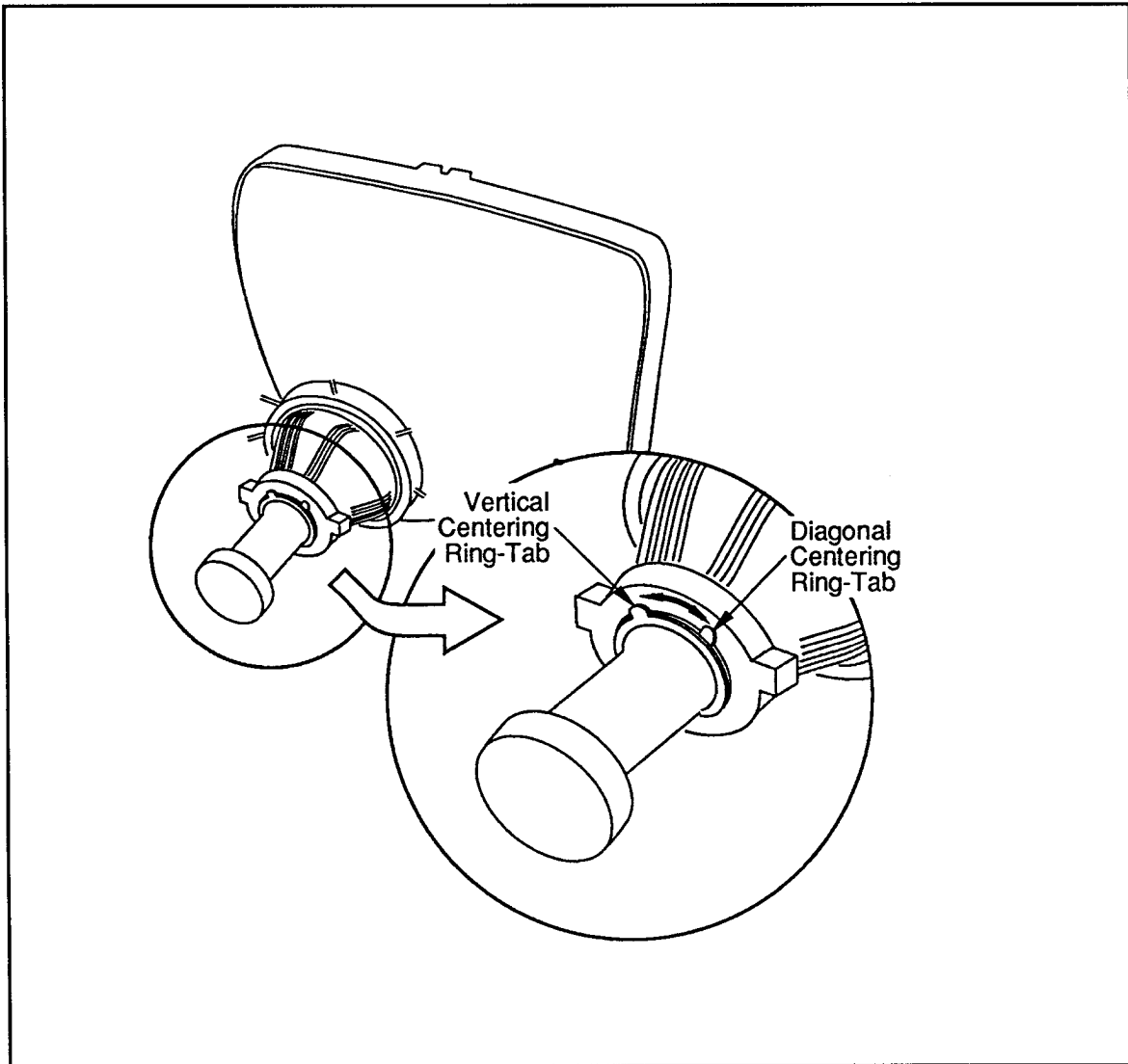

Figure 5-4. Centering ring locations on CRT yoke.

Section 6

DISASSEMBLY/ASSEMBLY

In the following procedures, directional terms (top, bottom, left, right, etc.) are based on the assumption that your instrument is in a normal, upright position and that you are facing the front of the instrument.

Installation or reassembly procedures are the reverse of the disassembly procedures unless otherwise noted. In some cases, installation hints are provided to aid in assembly procedures.

WARNING

Be sure the power cord is disconnected before removing the covers. Serious shock hazards are exposed when the covers of the Mainframe are removed. Disassembly procedures should only be attempted by qualified service personnel.

This section describes the following:

- General disassembly/installation precautions
- How to remove and install each Mainframe module
- How to disassemble/assemble selected modules
- How to position the MPU board and application module for troubleshooting

GENERAL DISASSEMBLY/INSTALLATION PRECAUTIONS

- DO NOT attempt any disassembly or installation procedures when the power cord is connected to the instrument.
- DO NOT operate the instrument with the cover removed unless additional instrument cooling is provided.

MAINFRAME DISASSEMBLY/ASSEMBLY

Disassembly/assembly information is provided for the following:

- Cabinet Cover
- Application module
- MPU Board and Interconnect Board
- Hard Disk Drive and Hard Disk Controller
- Floppy Disk Drive
- Power Supply Module and Power Distribution Board
- Front Panel and Keypad
- Video Control Board
- CRT
- Fan

Illustrations are provided in this section to aid the disassembly/assembly procedures. On occasion, you may find it helpful to refer to Cabling and Connector information in Section 3, signal interconnect diagrams in Section 10, and the detailed mechanical illustration in Section 11.

Procedure A. Mainframe Cover

To remove and install the Mainframe Cover, perform the following:

1. Switch STANDBY/ON switch to STANDBY and remove power cord from instrument.
2. Position instrument face down on soft pad as shown in Figure 6-1 and remove bezel.
3. Remove application module bezel screws and rear cabinet screws as shown in Figure 6-1.
4. Using both hands, grasp handle where handle connects to sides of cover and lift cover up and off the chassis. A gentle left-and-right rocking of cover may be necessary.
5. Set cover aside.
6. To install the cover, perform step 2 then 4 and 3. Observe the following precautionary guidelines when installing the cover.

CAUTION

When sliding the cover over the chassis, use care not to damage the video and TekLink cables by pinching them between the cover and chassis.

NOTE

When you install the cover, make sure the front edges of the cover slide over the EMI gasket material around the front edge of the Front Panel assembly. Make sure the cover slides between the front bezel and chassis before tightening the screws. Replace damaged EMI gaskets.

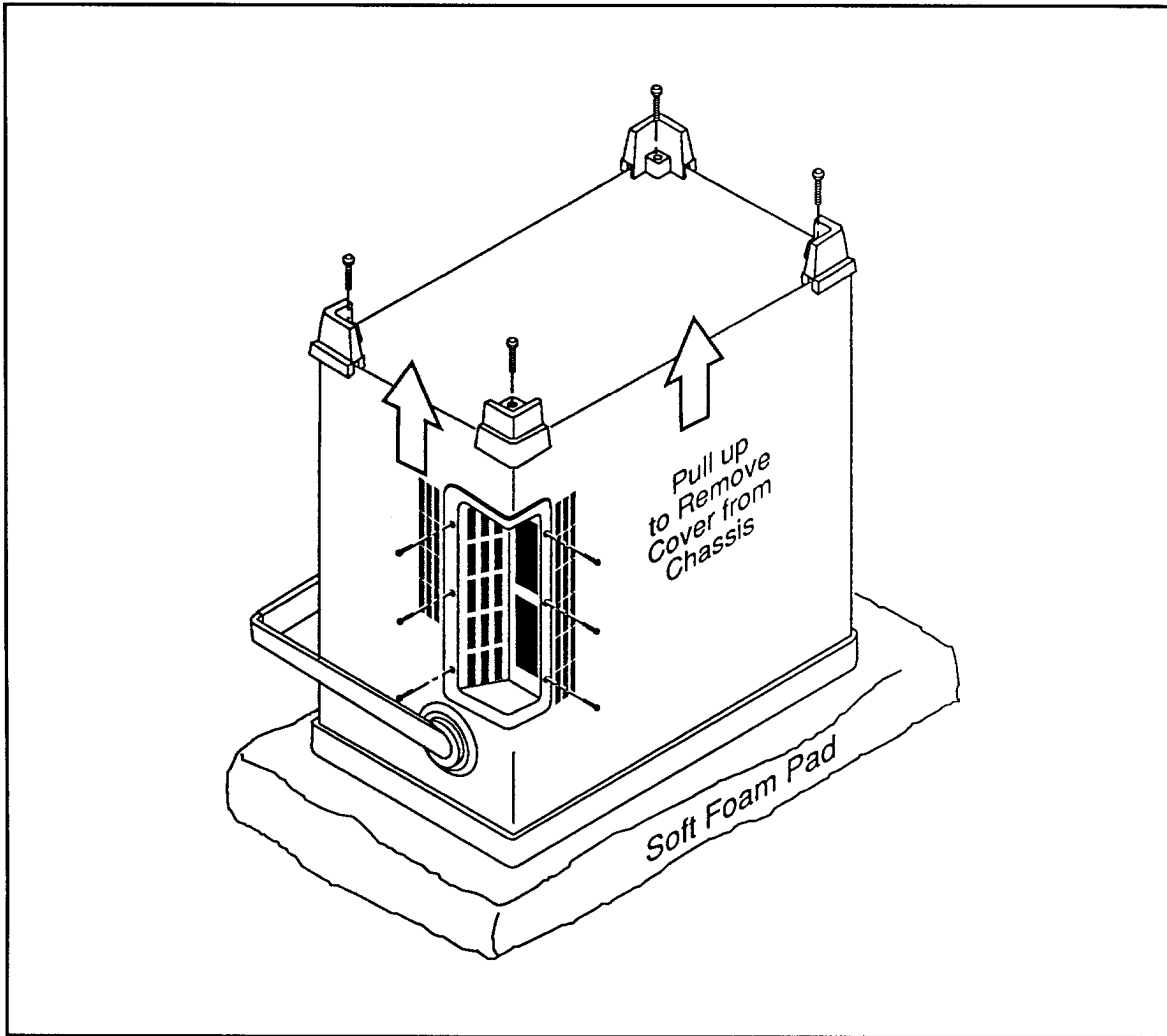

Figure 6-1. Removing the mainframe cover.

Procedure B. Application module

To remove and install an application module, perform the following:

1. Perform Procedure A.
2. Remove the 11 (eleven) acquisition board mounting screws shown in Figure 6-2.
3. Disconnect the TekLink and Power cables from the application module.
4. To install an application module, perform steps 1-3 in reverse order, beginning with step 3.

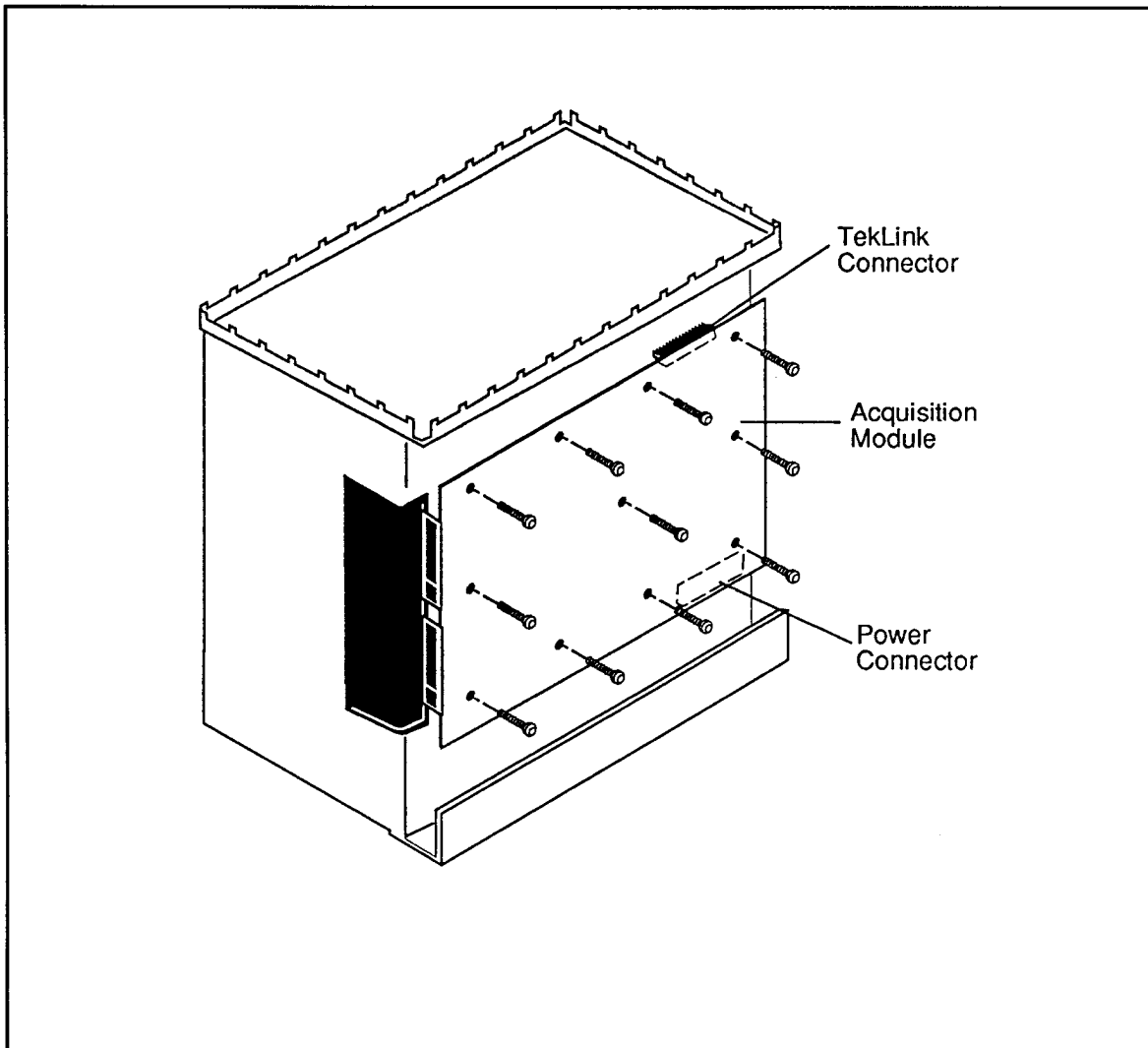

Figure 6-2. Removing the application module.

Procedure C. MPU Board and Connector Adapter Board

To remove and install an MPU board, perform the following:

1. Perform Procedure A.

CAUTION

If you are not going to remove the application module, do not place the instrument on tools or other raised items that could damage the module.

2. Place instrument on a static-free work surface as shown in Figure 6-3.
4. Remove all cables from the MPU board.
5. If you are removing the Connector Adapter board, perform the following; otherwise, continue with Step 6.

Disconnect the video, TekLink, and +5 VDC wire from Connector Adapter board (See Figure 6-3).

CAUTION

The interconnect pins between the MPU board and Connector Adapter board are fragile and can be easily broken. Therefore, use care when removing the Connector Adapter board so as not to bend any interconnect pins.

Remove the Connector Adapter board by grasping board between your thumb and forefinger. Pull board up and off the MPU board with a gentle rocking motion.

NOTE

Before reinstalling a Connector Adapter board, make sure the interconnect pins from the MPU board are not bent. Carefully straighten any bent pins.

6. Remove screws A, B, C, D, and E as shown in Figure 6-3.
7. Tilt the rear of MPU board up and out of cabinet.
8. To install the MPU board with Connector Adapter board, perform steps 7 through 1 in that order.

NOTE

If needed, refer to Figure 3-1 in Section 3 to ensure cables are reconnected properly to the MPU board.

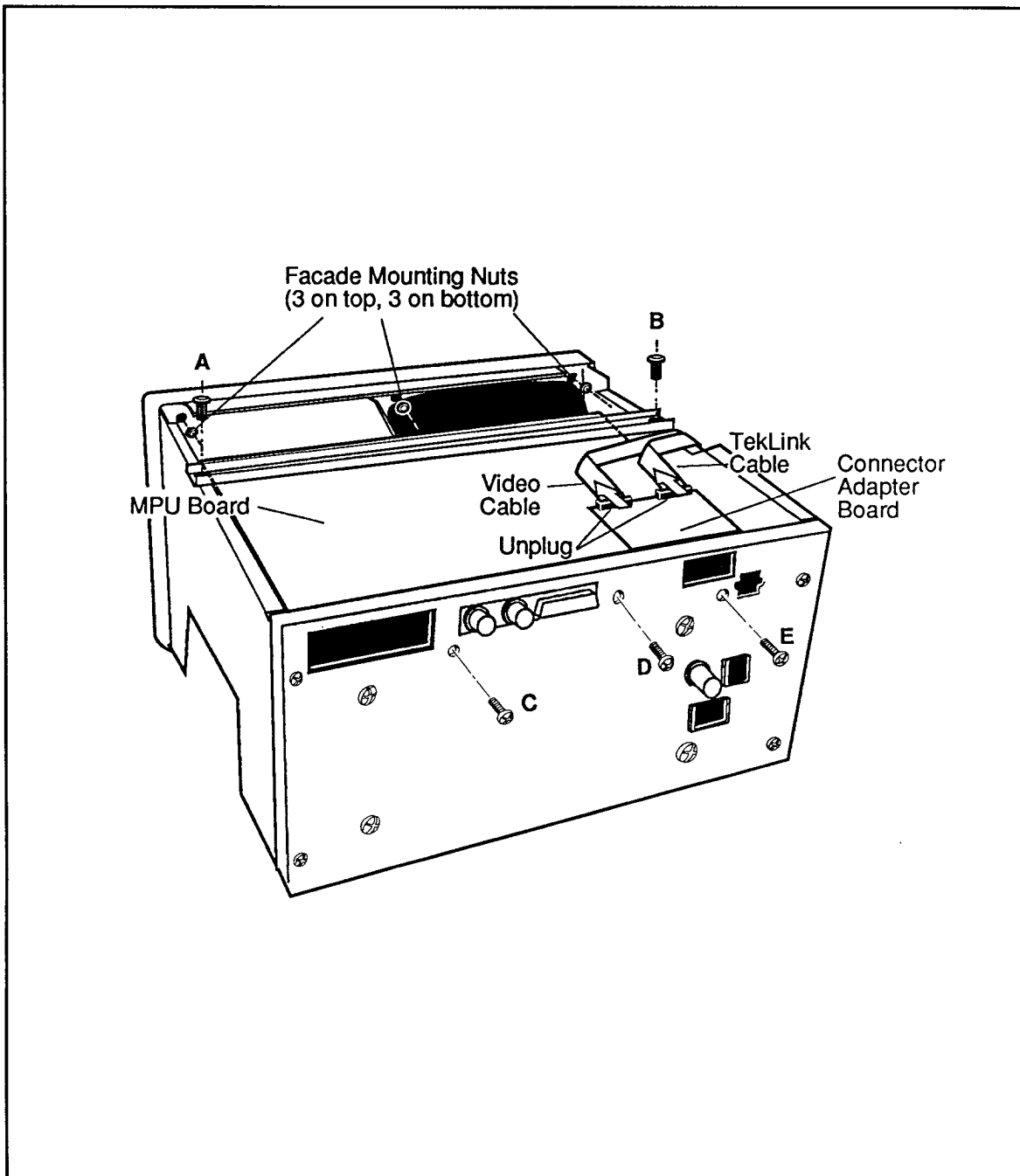

Figure 6-3. MPU and Connector Adapter board removal.

Procedure D. Hard Disk Drive Assembly

Use procedure D-1 if your instrument has an IDE interface hard drive. Use procedure D-2 if your instrument has an ST506/412 interface hard drive.

Procedure D-1. Hard Disk and IDE Interface Board (IDE Interface Family)

To remove and install the hard disk and IDE Interface board, perform the following procedures.

1. Perform Procedures A and C.
2. Refer to Figure 6-4 and remove the four screws holding the hard disk bracket to the chassis.

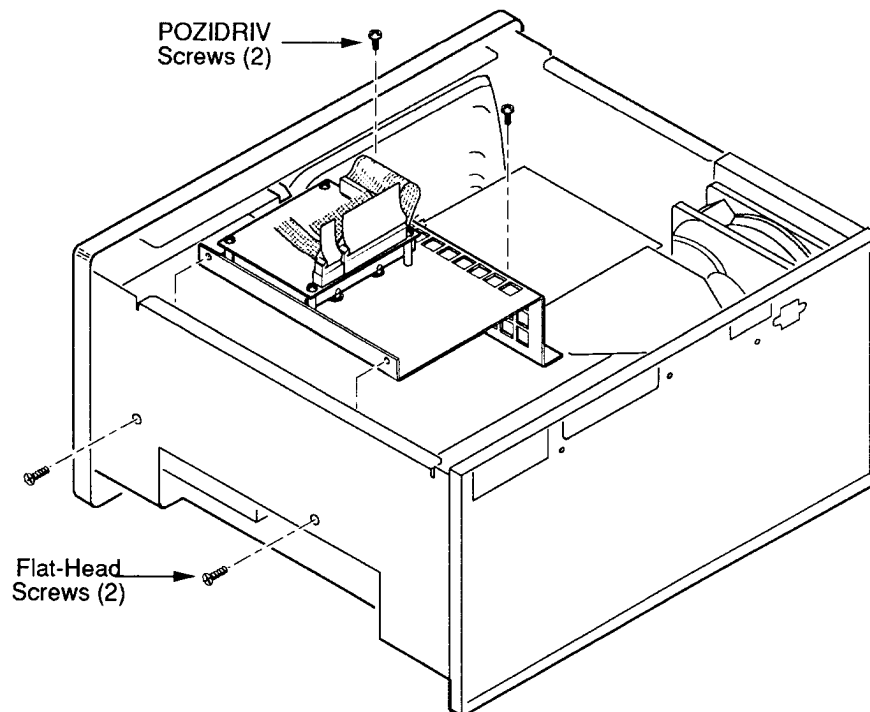

Figure 6-4. Removing the hard disk drive assembly.

3. Lift the hard disk bracket and the attached hard disk from the chassis.
4. To remove the IDE Interface board, refer to Figure 6-5 and remove the cable connectors from the drive. Then remove the four screws holding the board to the mounting studs on the hard disk drive assembly.

Disassembly/Assembly

5. To remove the drive from the hard disk drive assembly, refer to Figure 6-5 and carefully remove the four screws that hold the drive assembly to the bracket. (There are two shoulder washers for each screw.) Then slide the drive out of the assembly.

NOTE

Be careful not to damage or lose the fiber shoulder washers. These washers isolate the hard disk drive from chassis ground.

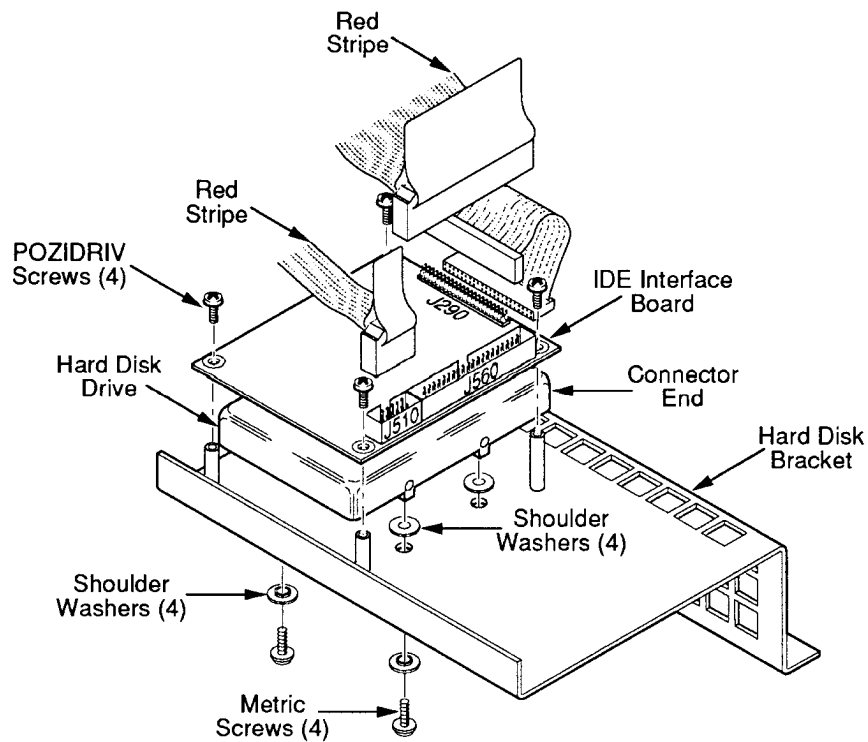

Figure 6-5. The hard disk drive assembly.

The remainder of the steps describe how to reinstall the hard disk drive assembly.

6. To replace the hard disk drive in the assembly, follow these steps:
 - a. Place the shouldered portion of four shoulder washers into the mounting holes for the hard disk drive on the top of the hard disk bracket.
 - b. Place the hard disk drive onto the hard disk bracket over the shoulder washers with the connector end as shown in Figure 6-5.
 - c. Hold the the hard disk drive in place and turn the hard disk bracket over to expose the underside of the bracket.
 - d. Place the shouldered portion of the remaining four shoulder washers into the four mounting holes for the hard disk drive on the underside of the hard disk bracket.
 - e. Attach the hard disk drive to the hard disk bracket with the four metric screws that you removed earlier.
7. To replace the IDE Interface board in the assembly, follow these steps:
 - a. Place the IDE Interface board over the mounting studs on the top of the hard disk bracket as shown in Figure 6-5.
 - b. Attach the IDE Interface board to the mounting studs with four POZIDRIV screws removed earlier.
 - c. Connect the 44-conductor ribbon cable to the hard disk drive first and then to J290 on the IDE Interface board. There is a plug or key in pin 20 of one of the cable connectors as shown in Figure 6-5a; connect this end to the hard disk drive.

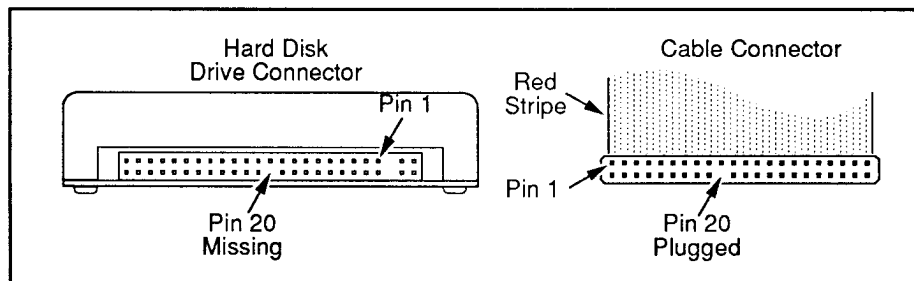

Figure 6-5a. Connecting the hard disk drive cable.

- d. Connect the 10-conductor ribbon cable to J510 on the IDE Interface board. Ensure that pin 1 of the cable (indicated by the red stripe) connects to pin 1 of connector J510 (indicated by the arrow on the connector housing).
- e. Connect the 40-conductor ribbon cable to J560 on the IDE Interface board. Again, ensure that pin 1 of the cable (indicated by the red stripe) connects to pin 1 of the connector J510 (indicated by the arrow on the connector housing).

Disassembly/Assembly

8. To replace the hard disk drive into the mainframe, follow these steps:
 - a. Place the IDE-interface hard disk drive assembly into the mainframe as shown in Figure 6-4. Ensure that no cabling is caught under the hard disk bracket.
 - b. Align the two holes in the disk mounting bracket with the two countersunk holes in the right side of the chassis.
 - c. Thread the two flat-head screws into the holes, but do not tighten them.
 - d. Align the two holes in the bottom lip of the disk mounting bracket with the two holes in the bottom of the chassis.
 - e. Attach the disk mounting bracket to the bottom chassis with the two remaining POZIDRIV screws.
 - f. Tighten the two flat-head screws that attach the hard disk bracket to the right side of the chassis.

Procedure D-2. Hard Disk and Hard Disk Controller (ST506/412 Interface Family)

To remove and install the hard disk and hard disk controller board, perform the following procedures.

1. Perform Procedures A and C.
2. Refer to Figure 6-5b and remove the four screws holding the hard disk bracket to the chassis.

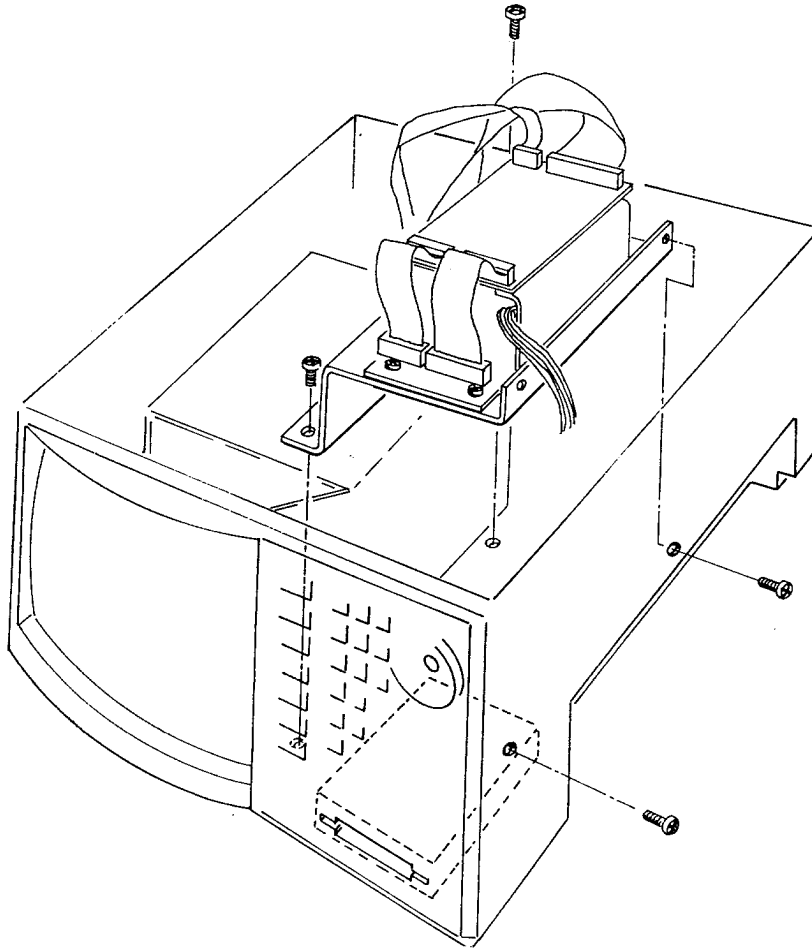

Figure 6-5b. Hard disk bracket screws.

3. Lift the hard disk bracket and the attached hard disk from the chassis.
4. To remove the Controller board, refer to Figure 6-5c and remove the edge card connectors from the drive. Then remove the four screws holding the board to the hard disk unit assembly.
5. To remove the drive from the hard disk unit assembly, refer to Figure 6-5c and perform the following:
 - a. Remove the four screws that hold the unit assembly to the bracket.
 - b. Remove the four screws that hold the drive to the unit assembly.
 - c. Slide the drive out of the unit assembly.

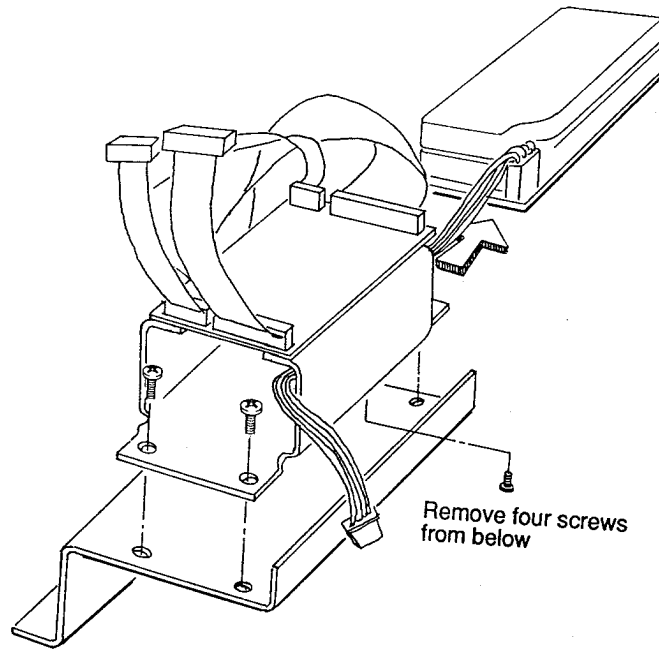

Figure 6-5c. Hard disk drive and controller.

6. To install the hard disk into the mainframe, do steps 5 through 1 in that order.

Procedure E. Floppy Disk Drive

To remove and install a Floppy Disk Drive module, perform the following:

1. Perform Procedures A, B, C, and D.
2. Place instrument on left side as shown in Figure 6-6.
3. Disconnect the power and data/control cables from rear of Floppy Drive module.
4. Remove three of the four metric screws that fasten the Floppy Drive module to the chassis.
5. Hold the Floppy Disk module with one hand while removing the fourth mounting screw.

NOTE

Keep these metric screws where they can be easily located when installing the floppy drive. These are the only metric screws used in the Mainframe.

6. Remove the Floppy Drive Module by sliding the unit through the front of the front panel.
7. To install the Floppy Drive module, perform steps 6 through 1 in that order.

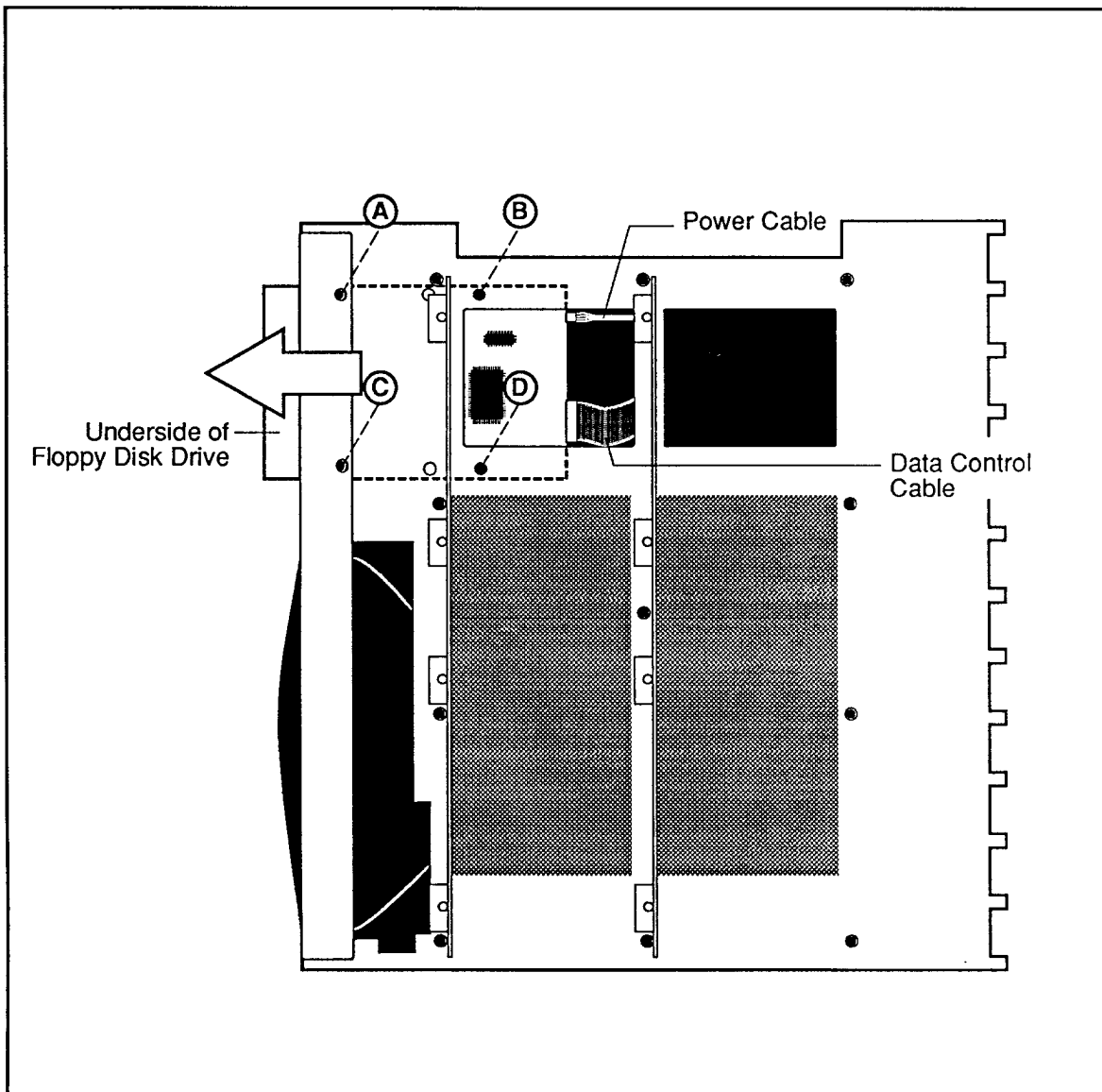

Figure 6-6. Removing the Floppy Disk Drive.

Procedure F. Power Supply Module and Power Distribution Board

To remove and install the Power Supply module and Power Distribution board, perform the following. Refer to the AC and DC Power Interconnect and Cabling diagram in Section 10 as an aid for disassembly and assembly.

1. Perform Procedures A and C.
2. Remove screws F, G, H, and I shown in Figure 6-3.
3. Remove fan connector(s) from Power Distribution board.
4. Note wire arrangement/sequence at J350, and then remove all wires to J350 (Application module power connectors).
5. Remove the AC line and neutral wires from AC Line Relay and Line and Neutral connections of same wires on Power Distribution board.
6. Remove the two 115/230 VAC selector wires for Power Supply module from the LINE VOLTAGE SELECTOR switch.
7. Using a 5/16 inch box-end wrench, remove the power supply ground wire from the chassis ground lug.
8. Pull Power Supply module from cabinet.
9. To remove the Power Distribution board from the Power Supply module, perform the following:
 - a. Disconnect all DC power wires from J150 on Power Distribution board.
 - b. Remove Line and Neutral wires at pins 7 and 9 on the AC Relay.
 - c. Remove 6 screws that fasten the Power Distribution board to the Power Supply module.
 - d. To install the Power Distribution board on the Power Supply module, perform Steps c through a in that order.
11. To install the Power Supply module with Power Distribution board, perform steps 9 through 1 in that order.

Procedure G. Front Panel Assembly and Keypad

You must remove the Front Panel Assembly to access the Keypad. Proceed as follows:

1. Perform Procedures A and B.
2. Disconnect cables at rear of Keypad.
3. Using a 3/8 nut driver, remove the six nuts that hold Front Panel Assembly to chassis.
4. Gently pull the Front Panel away from the front of the chassis, feeding the function key signal cable from under the CRT.
5. If replacing the Front Panel Assembly (with Keypad), continue with step 8. If replacing the Keypad, proceed with step 6. If replacing the Keypad Circuit board, proceed with step 7.
6. To remove the Keypad from the Front Panel Assembly, perform the following:
 - a. Remove screws A and B shown in Figure 6-7.
 - b. Allow the Keypad to "fall" away from the Front Panel Assembly.

NOTE

When installing the Keypad, ensure that the hinge tabs are positioned as shown in Figure 6-7.

- c. To install the Keypad in the Front Panel Assembly, perform step b then a.
7. To remove the Keypad circuit board from the rear of the Keypad, perform the following steps:

NOTE

The Keypad circuit board can be removed with the Keypad either installed in or removed from the Front Panel Assembly.

- a. Remove the six plastic nuts shown in Figure 6-7.
 - b. Grasp the circuit board between your thumb and forefinger near the top of the board. Using a gentle rocking motion, pry the board off the keypad interconnect pins.

NOTE

Use care when moving the Keypad with the circuit board removed. The plastic standoffs on the mounting studs will fall off if panel is tipped.

When re-installing the Keypad circuit board on Keypad, make sure interconnect pins are aligned.

- c. To install the Keypad circuit board, perform steps a and b in reverse order, beginning with step b.

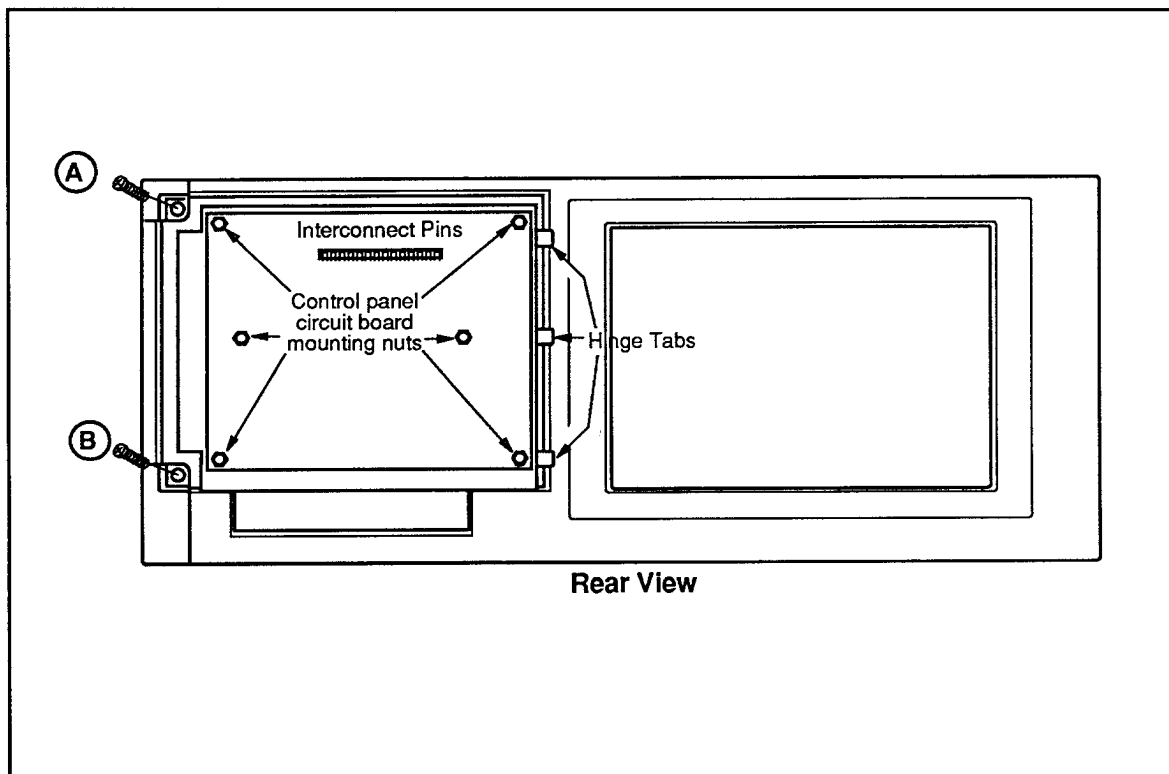

Figure 6-7. Removing Keypad circuit board from Front Panel Assembly.

8. To install the Front Panel Assembly, proceed as follows:
 - a. Feed the Function Key cable through the cable slot directly under the CRT.
 - b. Align and position the mounting studs through the six holes in the chassis.

CAUTION

When installing the front cover, do not excessively torque the mounting nuts, as the plastic studs can be damaged or broken.

- c. Install and gently tighten the nuts onto the six front panel studs.
- d. Route Function Key cable under CRT and through the cable access hole at bottom of the CRT shield. Connect cable to Keypad circuit board through access hole on back of Keypad shield.

NOTE

Pin 1 on the Keypad circuit board is the top pin on the board connector and is marked on the panel.

Disassembly/Assembly

- e. Connect the signal cable (from Keyboard Multiplexer/EMI Filter board) to Keypad circuit board through the access hole on back of the keypad shield.
9. Install application module by performing Procedure B in reverse order.
10. Install the Mainframe cover by performing Procedure A in reverse order.

Procedure H. Display Control Board

To remove and install the Display Control board, perform the following:

1. Perform Procedures A and C.

WARNING

USE EXTREME CARE WHEN WORKING NEAR OR HANDLING THE CRT. Do not nick or scratch the glass, or subject it to undue pressure during removal or installation. Rough handling may cause it to violently implode. When handling the CRT, wear safety goggles and heavy gloves for protection.

WARNING

The CRT anode forms a capacitor with the external CRT DAG coating. If the DAG spring is not present to ground the CRT, hazardous voltages may exist on the outside of the CRT. Always replace the CRT shield before powering up the instrument.

2. Remove the three screws from the top of the CRT shield and remove the top of the shield from the instrument.

WARNING

TO AVOID SERIOUS SHOCK HAZARD, BEFORE ATTEMPTING ANY WORK ON OR IN THE AREA OF THE CRT, discharge the CRT by simultaneously shorting the anode connection to chassis ground using a plastic-handle screwdriver. When discharging the CRT, place the metal blade of the screwdriver against the chassis, then slip the screwdriver tip under the CRT anode cup.

3. Remove the high voltage anode lead from the CRT, and remove the anode wire from the plastic clamp on the bottom the chassis.
4. Remove cables and the DAG ground lug from Display Control board.

5. Remove four board mounting screws, one at each corner of the board. (The top two screws are accessed from the inside of the chassis; the bottom two from the outside of the chassis.)
6. Pull the Display Control board from the chassis.
7. To install the Display Control board, perform steps 6 through 1 in that order.
8. Check CRT alignment and adjust as needed following adjustment procedures provided in Section 5.

Procedure I. CRT

To remove and install the CRT, perform the following:

WARNING

CRTs RETAIN HAZARDOUS VOLTAGES FOR LONG PERIODS OF TIME AFTER POWER DOWN. The CRT should be serviced only by qualified personnel familiar with CRT servicing procedures and precautions.

WARNING

TO AVOID SERIOUS SHOCK HAZARD, BEFORE ATTEMPTING ANY WORK ON THE CRT, discharge the CRT by simultaneously shorting the anode connection to chassis ground using a plastic-handle screwdriver. When discharging the CRT, place the metal blade of the screwdriver against the chassis, then slip the screwdriver tip under the CRT anode cup.

WARNING

USE EXTREME CARE WHEN WORKING NEAR OR HANDLING THE CRT. Do not nick or scratch the glass, or subject it to undue pressures during removal or installation. Rough handling may cause it to violently implode. When handling the CRT, wear safety goggles and heavy gloves for protection.

WARNING

The CRT anode forms a capacitor with the external CRT DAG coating. If the DAG spring is not present to ground the CRT, hazardous voltages may exist on the outside of the CRT. Always replace the DAG ground spring before powering up the instrument.

1. Perform Procedures A, C, and G.
2. Perform steps 2, 3, and 4 of Procedure H.
3. Remove three of the four CRT mounting screws from the front corner tabs of the CRT.
4. Hold the CRT at its rear while removing the fourth screw, then using both hands, gently slide the CRT through the opening in the front of the CRT.
5. Place the CRT face down on a soft clean surface.
6. To install a CRT, perform steps 4 through 1 in that order.

NOTE

Make sure CRT DAG ground spring is properly installed before installing CRT.

7. Check CRT alignment and adjust as needed using the CRT adjustment procedures provided in Section 5.

Procedure J. Fan

To remove and install the chassis fan, perform the following:

1. Perform Procedure A.
2. Remove the fan power and ground wires from the fan. Note and identify +5 VDC and ground wires for reassembly.
3. Remove four (4) fan mounting screws accessible through left rear of chassis.

CAUTION

When installing a fan, use minimal torque when tightening fan screws. Threads on the fan screws can be easily stripped.

4. Pull fan from chassis.
5. To install fan, performs steps 4 through 1 in that order.

OPTIONAL KEYBOARD DISASSEMBLY/ASSEMBLY

Use the following procedures to replace keycaps and the keyboard interconnect cable.

Replacing Keycaps

QWERTY Keys. All QWERTY keys can be removed without removing the back plate. See Figure 6-8 when performing the following procedures.

First, place a small flat-blade screwdriver behind the desired cap. Using another screwdriver, gently pry up on the front of the keycap. The keycap will pop off. If the retaining sleeve comes off with it, pry the sleeve off the cap and re-insert the sleeve into the keyboard. To install a new keycap, push it into place until it makes a gentle snap.

The space bar has two springs that fit on two posts. Be sure they are installed when replacing space bar. Also, be sure to properly connect the stabilizing bar to the two hooks on the keyboard.

NOTE

When removing the keyboard back plate, keep the keyboard face down or all of the keys will fall out.

Non-QWERTY Keys. To remove the non-QWERTY keys (including the SEL knob), you must turn the keyboard upside-down and remove the 11 POZIDRIV screws that secure the back plate. Next, remove the back plate, circuit board, and elastomer switch pad, noting their original position. To remove the non-QWERTY keys, push them out of their holes and lift them out the back of the keyboard.

CAUTION

When you replace the 11 POZIDRIV screws, be sure they are perfectly aligned. Non-aligned screws may result in stripped threads.

To remove the SEL knob, unscrew the POZIDRIV screw on the back of the SEL knob and pull the knob out the front of the board. When reinstalling the SELECT Knob, you may have to experiment with the correct screw torque in order obtain the best rotational feel.

NOTE

Be careful when positioning the keyboard with the assembly removed from its mechanical enclosure. The keycaps can easily fall from their assigned holes. If this happens, refer to Figure 6-9. This figure illustrates the assigned positions for each keycap.

Replacing the Keyboard Cable

Remove the back plate as described in the preceding paragraphs. The circuit board will be visible. Unsolder the old cable and solder the new one in. Pin keying is silk screened on the circuit board. Table 6-1 shows the cable pinout and color-code.

Table 6-1
Keyboard Cable Pinout and Color-code

Pin Number	Wire Color
1	orange
2	red
3	yellow
4	brown
5	white
6	black (shield)

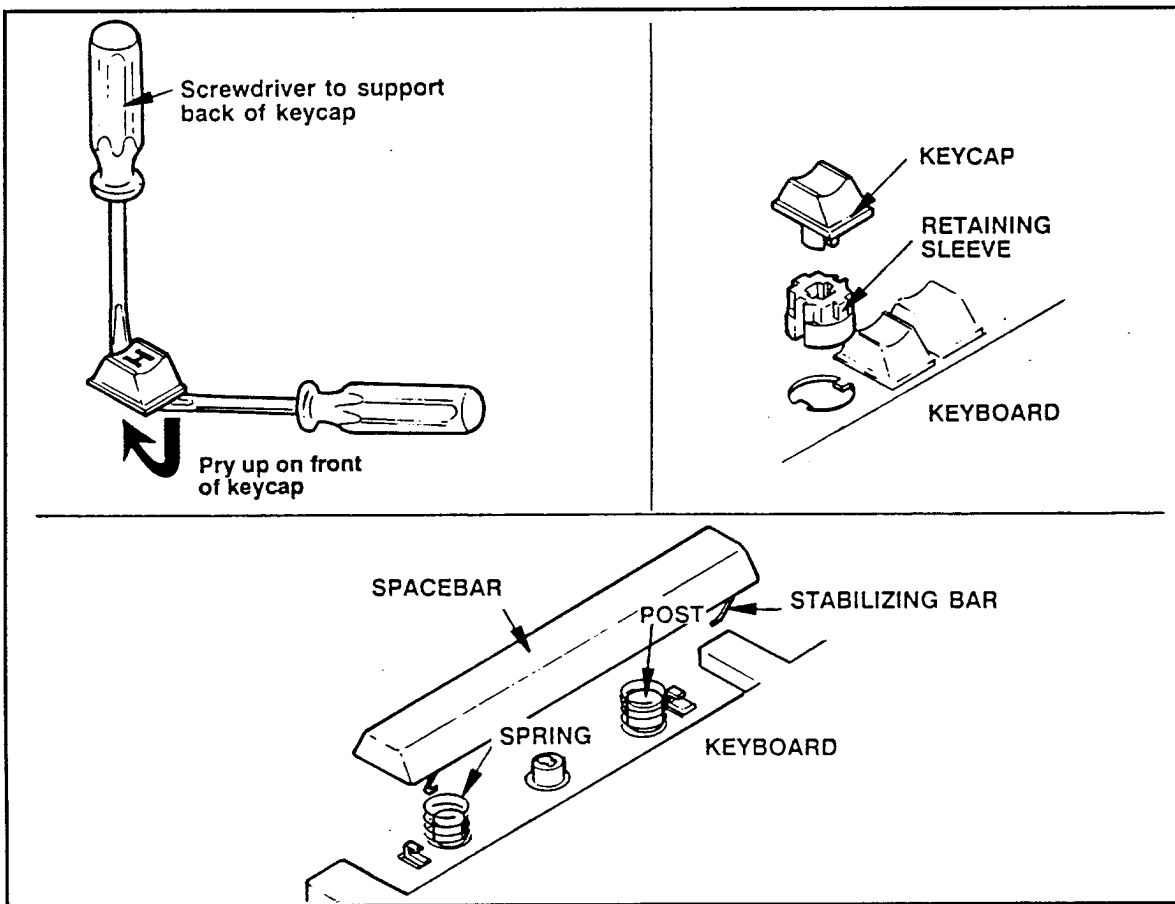
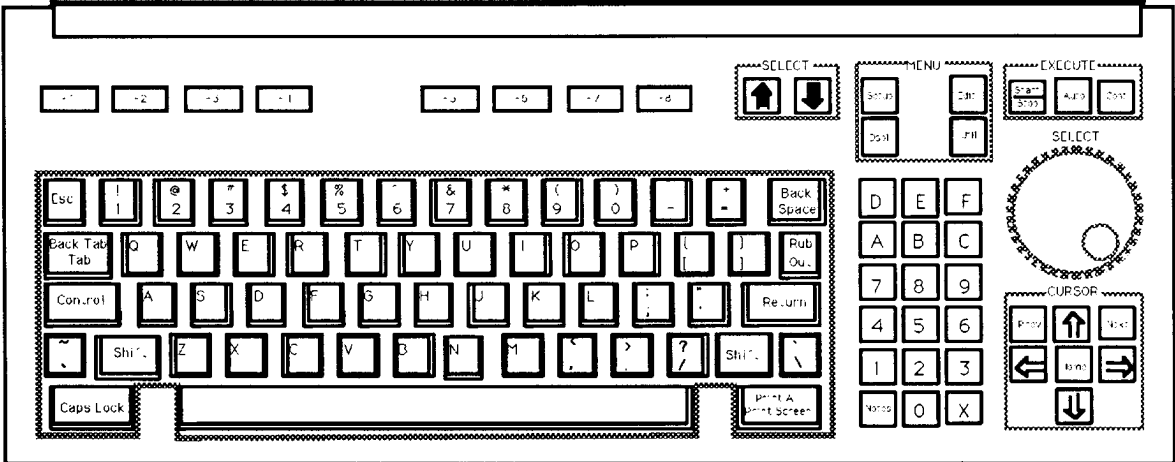
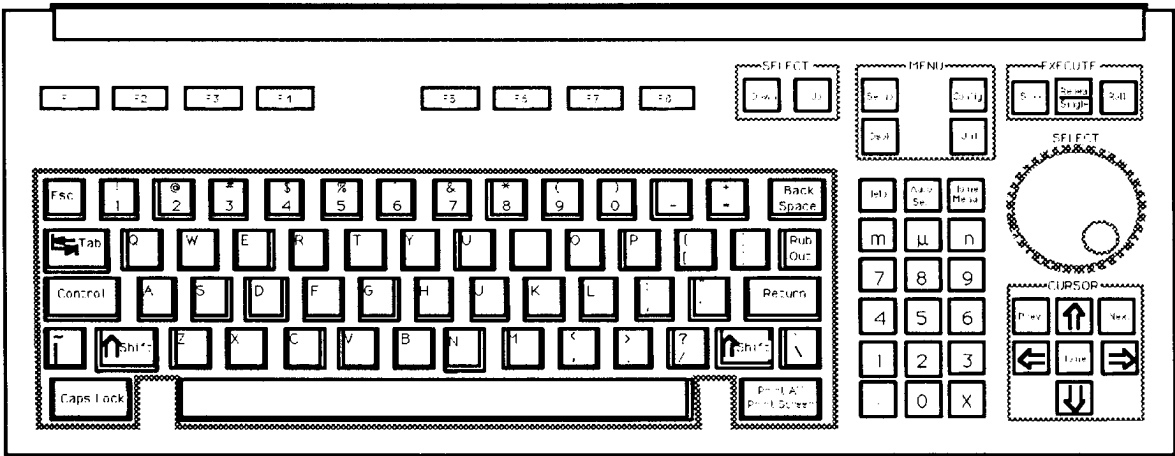

Figure 6-8. Replacing keycaps.



A. 3001 keyboard.



B. TestLab Keyboard.

Figure 6-9. Keycap templates.

PLACEMENT OF MODULES FOR TROUBLESHOOTING

As installed, the MPU board and application module permit limited access to their respective components for troubleshooting purposes. However, these modules can be positioned to allow full access to the component side of each module. You can access the component side of modules for troubleshooting as follows:

CAUTION

AN APPLICATION MODULE REQUIRES AIR MOVEMENT FOR COOLING. If you troubleshoot an application module outside the mainframe, position a cooling fan to blow air across the module. (With the mainframe cover removed, the Power Supply's fan cannot cool the module.)

1. Remove the instrument cover as described in Procedure A, this section.
2. Remove the application module as described in Procedure B, leaving its power cable connected.
3. Place the instrument and application module on a non-conductive work surface as shown in Figure 6-10.
4. Remove the MPU board as described in Procedure D. However, leave the MPU board cables connected, and placing a non-conductive pad between the MPU board and the chassis, position the board as shown in Figure 6-10.
5. Reroute the TekLink connector and connect it to the application module as shown in Figure 6-10.
6. To reassemble the instrument, perform steps 5 through 1 in that order.

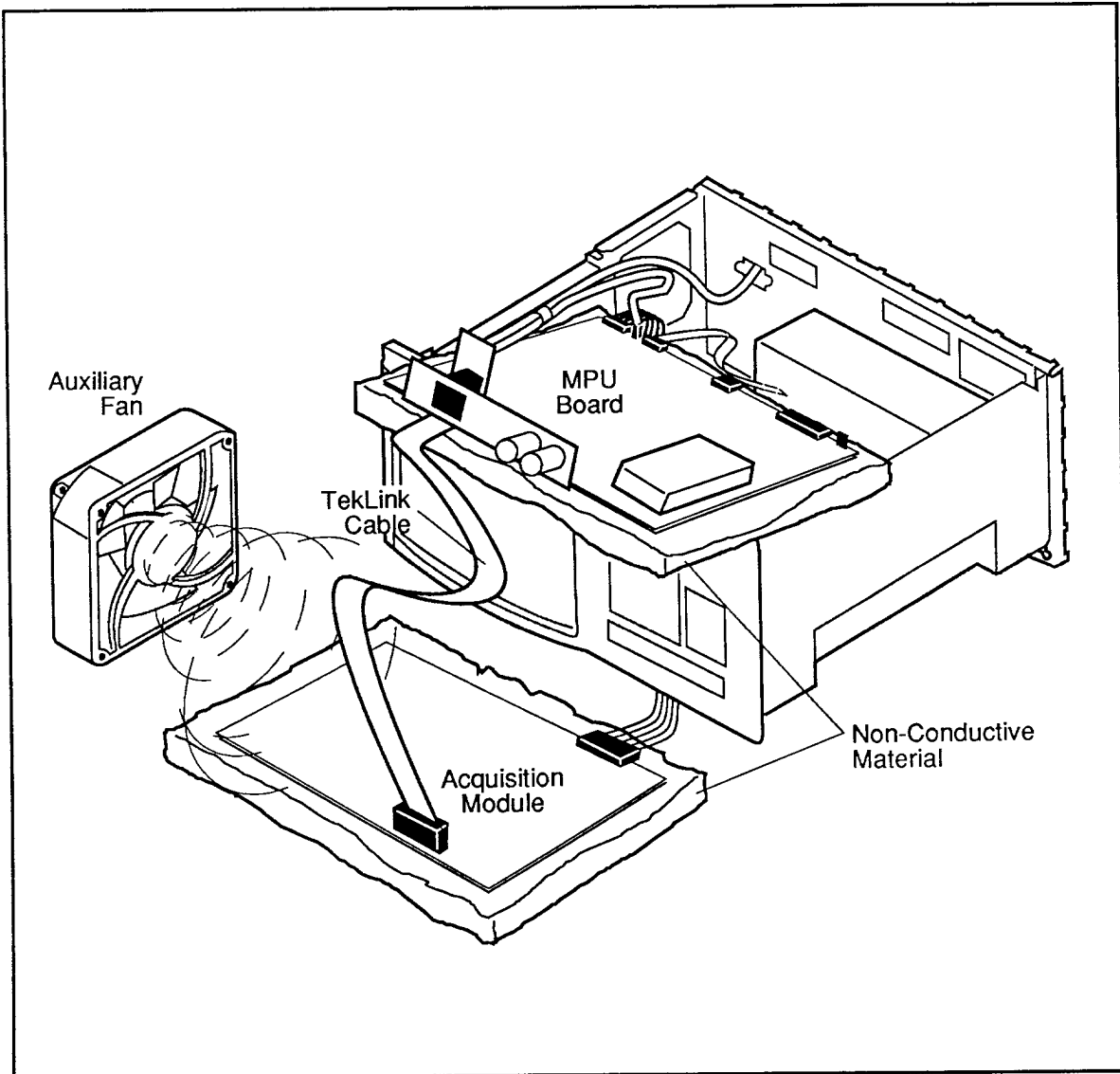

Figure 6-10. MPU board and Application module in troubleshooting position. Note auxiliary fan used to cool module.

Section 7 MAINTENANCE

This section contains the following information:

- Service Strategy
- Maintenance Tools
- General Maintenance Precautions
- Preventive Maintenance Information
- Corrective Maintenance Information

SERVICE STRATEGY

All modules can be ordered as replaceable assemblies to support timely, on-site repair. Modules can then be repaired at field service centers or at factory repair facilities.

Some Mainframe modules can only be repaired at the factory. The *Electrical and Mechanical Parts* lists (Sections 9 and 11, respectively), provide complete lists of all field-replaceable electrical and mechanical parts.

Three circuit boards, described in this manual, can be repaired to the component level. These circuit boards are:

1. Power Distribution board
2. Connector Adaptor board
3. Keyboard Filter board

Each board is supported with detailed schematic diagrams, component location illustrations, and parts lists.

Finally, many mechanical parts and chassis-mounted electrical parts and cables can be ordered as replaceable parts. Check the *Electrical and Mechanical Parts* lists for a complete listing of replaceable parts. Refer to *Obtaining Replaceable Parts* later in this section for additional information.

Maintenance

MAINTENANCE TOOLS

The following tools are those most often needed when servicing the Mainframe or a circuit board:

- Soldering iron (≤ 18 W)
- Rosin core solder (60/40)
- Isopropyl alcohol
- Lint-free cloth
- Soft-bristle brush
- IC extractor
- Desoldering tool
- Solder wick
- Slotted screwdriver
- Magnetic screwdriver ($\frac{1}{4}$ inch drive)
- POZIDRIV-type bits, #1 and #2, for magnetic screwdriver
- Phillips-type bit #0
- $\frac{1}{4}$, $\frac{5}{16}$, $\frac{1}{2}$ inch combination wrenches

MAINTENANCE PRECAUTIONS

WARNING

Serious shock hazards are exposed when the Mainframe cover is removed. Do not remove the mainframe cover unless qualified to do so.

WARNING

Be sure to observe standard electrical precautions if the MPU board is in the service position when connected to other modules (application module, power supply, disk drive, etc.). Dangerous electric-shock and mechanical hazards may be exposed when the mainframe cover is removed. The fan is also exposed. Section 6 describes how to place the MPU and application module in a service position.

Refer all servicing to qualified service personnel. Unplug the mainframe from the power outlet immediately and notify the service technician if:

- Liquid has been spilled into the mainframe
- The mainframe has been exposed to rain or water
- The mainframe has been dropped or the cabinet damaged
- Fuses continue to blow
- Power cord is frayed or damaged
- A distinct change from normal operation is apparent

CRT Display Monitor

Be sure to observe the following warnings before and during any service work to, or in the area of, the CRT.

WARNING

Serious shock hazards are exposed when the mainframe cover is removed. Do not remove the mainframe cover unless qualified to do so.

WARNING

CRTs RETAIN HAZARDOUS VOLTAGES FOR LONG PERIODS OF TIME AFTER POWER DOWN. The CRT should be serviced only by qualified personnel familiar with CRT servicing procedures and precautions.

WARNING

TO AVOID SERIOUS SHOCK HAZARD, BEFORE ATTEMPTING ANY WORK ON THE CRT, discharge the CRT by simultaneously shorting the anode connection to chassis ground using a plastic-handle screwdriver. When discharging the CRT, place the metal blade of the screwdriver against the chassis, then slip the screwdriver tip under the CRT anode cup.

WARNING

USE EXTREME CARE WHEN HANDLING THE CRT. Rough handling may cause it to violently implode. Do not nick or scratch the glass, or subject it to undue pressures during removal or installation. When handling the CRT, wear safety goggles and heavy gloves for protection.

Maintenance

WARNING

If the DAG spring is not present to ground the CRT, hazardous voltages may exist on the outside of the CRT. The CRT anode forms a capacitor with the external CRT DAG coating. Always replace the DAG ground spring before powering up the instrument.

Soldering

Most electrical components are soldered in place.

CAUTION

If it is necessary to replace a soldered part, use a ≤ 18 W soldering iron to prevent heat damage to the circuit board or components. Excessive heat will lift circuit runs on the circuit board.

Refer replacement of soldered, multi-pin gate arrays to a Tektronix Service center where appropriate desoldering tools are available.

The flux in solder may leave a residue on the circuit board that can provide a high-resistance leakage path and affect electrical operation. Be sure to clean off this residue. Isopropyl alcohol is recommended.

Static Precautions

CAUTION

Static discharge can damage any semiconductor on this circuit board.

Observe the following precautions to avoid damage:

- Minimize handling of static-sensitive components.
- Transport and store static-sensitive components in their original containers, on a metal rail, or on conductive foam. Label any package that contains static-sensitive components.
- Discharge static voltage from your body by wearing a wrist strap when handling these components. Servicing static-sensitive components should be performed only at a static-free workstation by qualified service personnel.
- Don't put anything capable of generating or holding a static charge on the workstation surface.
- Avoid handling components in areas that have a floor or work-surface covering capable of generating a static charge.

- Keep component leads shorted together whenever possible.
- Pick up components by the body, never by the leads.
- Do not slide components over any surface.
- Use a soldering iron that is connected to an earth ground.
- Use only special anti-static suction type or wick desoldering tools.

NOTE

Damage to electrical components may not be immediately apparent. Always follow the precautionary measures previously listed when handling static-sensitive components.

AC Voltage Select Switch

CAUTION

Be sure that the VOLTAGE SELECT switch is set for the AC voltage being used. If not, set it to match the AC voltage; otherwise, power supply circuits can be damaged.

PREVENTIVE MAINTENANCE

Preventive maintenance consists of periodic cleaning and inspection. Accumulation of dust on components acts as an insulating blanket and prevents efficient heat dissipation. This condition can cause overheating and component breakdown. Periodic cleaning and inspection reduces instrument breakdown and increases instrument reliability.

The mainframe and associated modules should be cleaned as often as the operating environment requires. A convenient time to perform these procedures is immediately prior to troubleshooting or other maintenance-related activity. Perform these procedures more often if required by the operating environment.

CAUTION

Do not wash the rear panel STANDBY/ON switch. Washing may corrode the contacts making the switch inoperable. Cover the STANDBY/ON switch during washing procedures.

Spray-wash dirty parts with a cleaning solution listed under Interior Cleaning, then use deionized water to THOROUGHLY WASH all parts. IMMEDIATELY DRY all parts with a low speed air blower.

Maintenance

DO NOT use fluorocarbon-based spray cleaners, or chlorinated hydrocarbon cleaners; they may damage the circuit board material or plastic parts, and they may leave a dust-collecting residue.

To prevent damage from electrical arcing, ensure that all circuit board connectors are completely dry. Do this by heating the board in an oven at 75° C (176° F) for 15 minutes before installing into a mainframe and applying power.

Exterior Cleaning

Dust the exterior surfaces with a dry, lint-free cloth or a soft-bristle brush. If hard dirt remains, use a cloth or swab dampened with 50% mild detergent and warm water solution. The swab is also useful for cleaning in narrow spaces around controls and keys. Use the detergent solution for cleaning the display screen also. Do not use abrasive compounds on any part of the mainframe.

CAUTION

To prevent water from getting inside the instrument during external cleaning, use only enough water to dampen the cloth or swab. Water in the interior of the instrument may cause electrical arcing and damage the circuitry.

DO NOT use chemical cleaning agents as they may damage the plastics used in the mainframes. In particular, avoid chemicals that contain benzene, toluene, xylene, acetone, or similar solvents.

Interior Cleaning

To gain access to internal parts of a mainframe, refer to the Disassembly/Assembly procedures in Section 6.

Internal cleaning should be done with a clean, dry, low-velocity stream of air; however, take care not to aim the air stream directly at any other electrical modules that may be part of the instrumentation mainframe. A soft-bristle brush is useful for cleaning around components. If a liquid must be used for minor cleaning, use isopropyl alcohol, denatured ethyl alcohol, or a solution of 1% mild detergent and 99% deionized water.

Inspection

Inspect internal modules for broken connections, poorly seated components, leaking capacitors, damaged hardware, and heat-damaged components.

Repair any obvious problems. However, take particular care if you find any heat-damaged parts. Overheating usually indicates other circuit problems. To prevent recurrence of the damage, find and correct the cause of the overheating. Note that replacement of CRT-related electrical components may require you to perform the CRT adjustments. Refer to the *Replaceable Electrical Parts* section for a list of part and component descriptions.

CORRECTIVE MAINTENANCE

Corrective maintenance describes the following:

- Obtaining Replacement Parts
- Repairing Connectors

Obtaining Replacement Parts

Electrical and mechanical parts for mainframe modules can be obtained through your Tektronix field office or representative. However, many of the standard electrical components can be obtained locally. Before purchasing an ordinary part, check the *Replaceable Electrical Parts* section for a listing of value, rating, and description.

NOTE

Check the parts lists before replacing electrical components. If the part is called out as screen or burned-in, the replacement part must also be screen or burned-in or the repair will not be effective.

When selecting replacement parts, remember that the size and shape of a component may affect its performance. All replaceable parts should be direct replacements.

Some of the mechanical and electrical parts are manufactured by Tektronix. Some parts are manufactured or selected by Tektronix to satisfy particular design requirements or are manufactured to certain specifications for Tektronix. To determine the manufacturer of a part, refer to the Parts List Cross Index of Code Number to Manufacturer. This information is found in the replaceable parts sections.

When ordering replacement parts from Tektronix, include the following information:

- Instrument type
- Instrument serial number
- Description of the part (if electrical, include the component number)
- Tektronix part number

Circuit Board Pin Replacement

On occasion, it may be necessary to repair a circuit board connector pin. A circuit-board pin replacement kit, including the necessary tools, instructions, and replacement pins with attached spare ferrules, is available from Tektronix. Contact your Tektronix service representative for ordering information.

CAUTION

Use extreme care when replacing circuit board pins. Most circuit boards have conductive paths between the top and bottom board layers. All soldering, removal, and re-insertion of pins must be done with care to prevent breaking any electrical paths on the board.

Refer to Figure 7-1 when performing the following pin replacement procedures:

1. Use a 15 W soldering iron to unsolder the pin while pushing it out of the board with a pair of pliers. If the pin is too short to use pliers, push it out with any round device not over 0.28 inches in diameter.
2. If the ferrule remained in the board, go to step 3. If the ferrule came out with the pin, go to step 4.
3. If the ferrule remained in the board, perform the following:
 - a. Carefully ream the solder out with a 0.31 inch drill.
 - b. Remove the ferrule from a new pin and insert the pin into the old ferrule in the same orientation as the old pin.
 - c. Go to step 5.
4. If the ferrule came out with the pin, do the following:
 - a. Clean the excess solder out of the hole with a solder-removing wick and a scribe.
 - b. Insert the new pin with ferrule in the same orientation as the old pin.
 - c. Go to step 5.
5. When the new pin is properly positioned, carefully solder it on both sides of the board.
6. Clean any remaining residue from the board according to the *Cleaning* instructions given earlier in this section.

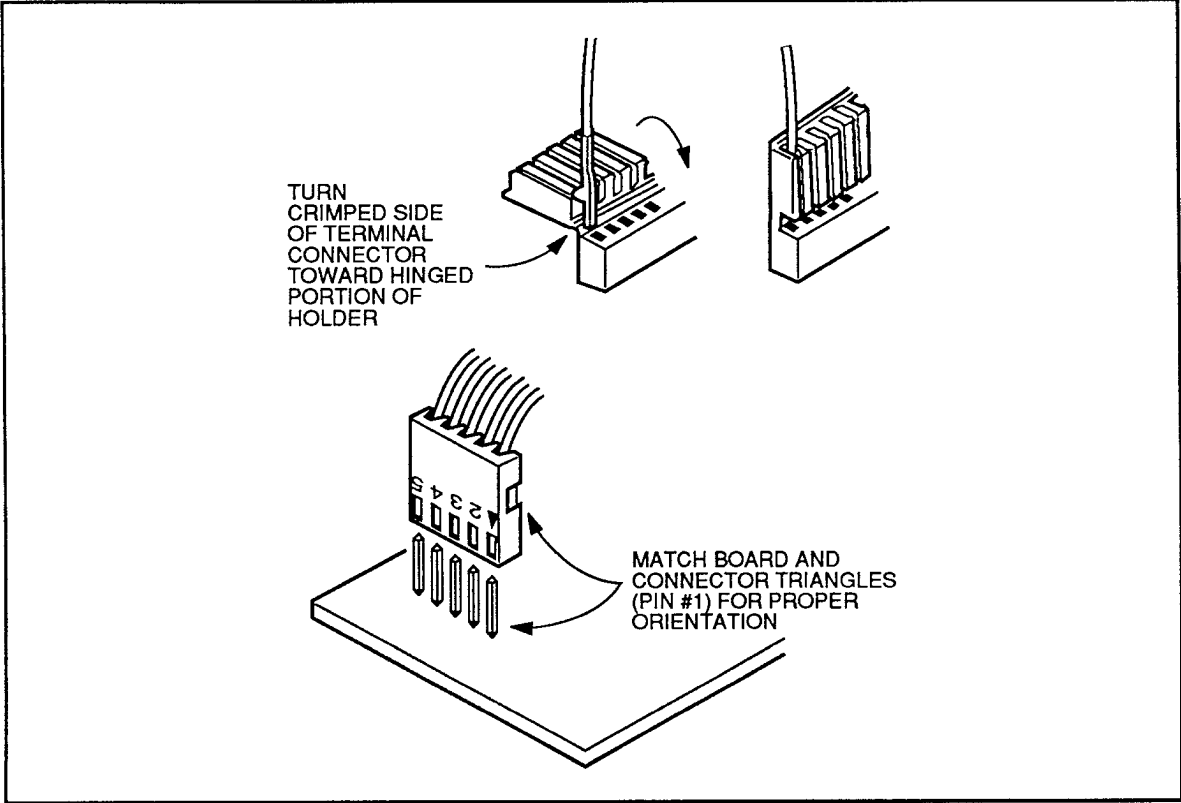

Figure 7-1. Circuit board pin replacement.

Section 8

TROUBLESHOOTING

Sophisticated diagnostics are included as part of the MPU board system firmware and software. These diagnostics verify the performance of the MPU board, Floppy Drive, CRT Display Module, Keypad, and optional keyboard. The application module is also supported with diagnostic software that exercises application module hardware.

Refer to the *MPU Board Service* manual and application module service manuals for descriptions of system diagnostic firmware and software. In most cases, the diagnostic tests identify the faulty mainframe module and aid troubleshooting to the component level.

In some cases, additional troubleshooting information may be needed. This section provides general troubleshooting guidelines for mainframe modules not supported with system diagnostics software.

Not all troubleshooting information is presented in this section. As required, references are made to other parts of this manual or to separate manuals.

Before you begin troubleshooting, read through this section to familiarize yourself with its contents. Topics covered in this section include:

1. Equipment List
2. Troubleshooting Precautions
3. Troubleshooting Positions for Mainframe Components
4. General Troubleshooting Information

TROUBLESHOOTING EQUIPMENT

Refer to Table 5-1 for recommended test equipment. Refer to *Section 7: Maintenance* for a list of tools required to service the mainframe.

TROUBLESHOOTING PRECAUTIONS

Review the following warnings and precautions before troubleshooting a mainframe.

Component Handling

If repair of the mainframe is to a lower level than board or module replacement, refer to *Section 7: Maintenance* of this manual for cautionary guidelines and recommended practices regarding the special handling required for static sensitive devices.

CAUTION

Static discharge can damage any semiconductor component in this instrument. Damage to electrical components may not be immediately apparent. Take standard anti-static precautions.

The CRT Display

Refer servicing of the monochrome monitor to qualified service personnel. Always observe the following precautions when working on the CRT.

WARNING

Serious shock hazards are exposed with the mainframe cover is removed. Do not remove the mainframe cover unless qualified to do so.

WARNING

CRTs RETAIN HAZARDOUS VOLTAGES FOR LONG PERIODS OF TIME AFTER POWER DOWN. The CRT should be serviced only by qualified personnel familiar with CRT servicing procedures and precautions.

WARNING

TO AVOID SERIOUS SHOCK HAZARD, BEFORE ATTEMPTING ANY WORK ON THE CRT, discharge the CRT by shorting the anode connection to chassis ground using a plastic-handle screwdriver. When discharging the CRT, place the metal blade of the screwdriver against the chassis, then slip the screwdriver tip under the CRT anode cup.

WARNING

USE EXTREME CARE WHEN HANDLING THE CRT. Rough handling may cause it to violently implode. Do not nick or scratch the glass, or subject it to undue pressures during removal or installation. When handling the CRT, wear safety goggles and heavy gloves for protection.

WARNING

If the DAG spring is not present to ground the CRT, hazardous voltages may exist on the outside of the CRT. The CRT anode forms a capacitor with the external CRT DAG coating. Always replace the DAG ground spring before powering up the instrument.

PLACEMENT OF MODULES FOR TROUBLESHOOTING

Refer to the *Disassembly/Assembly* section, for instructions on how to physically position the MPU board and application module for troubleshooting.

GENERAL TROUBLESHOOTING

The following provides general troubleshooting guidelines for circuitry and modules not supported with diagnostics firmware/software. Information presented here explains how to troubleshoot power supply problems and problems related to mainframe modules that are usually replaced as a unit (power supply, control panel, CRT display, optional keyboard, floppy drive and COMM Pack). Refer to the *MPU Board Service* manual for detailed system troubleshooting guidelines and System Diagnostics Software usage.

Troubleshooting System Power

There are several things to keep in mind when troubleshooting a system power problem.

First check the obvious:

- AC line cord properly installed
- Rear-panel STANDBY/ON switch in ON position
- Rear-panel AC line selector switched to proper position
- Rear-panel AC line fuse in good condition

If the obvious checks do not identify the problem, then the following information may prove helpful.

Troubleshooting

Power Distribution

The Power Distribution board distributes DC power to the MPU board and to the application module. The floppy drive, control panel, optional keyboard, CRT display module, and COMM Pack receive power via the MPU board. Refer to the interconnect diagrams in the Section 10 for power distribution. Refer also to Section 8 in the *MPU Board Service* manual for MPU board fuse locations and ratings.

Power Supply Troubleshooting Chart

When the system power troubleshooting items have been checked and the power supply refuses to come up, use the power supply troubleshooting chart in Figure 8-1. This chart will assist you in locating the problem area. Refer also to information immediately following titled *Troubleshooting Thermal Conditions*.

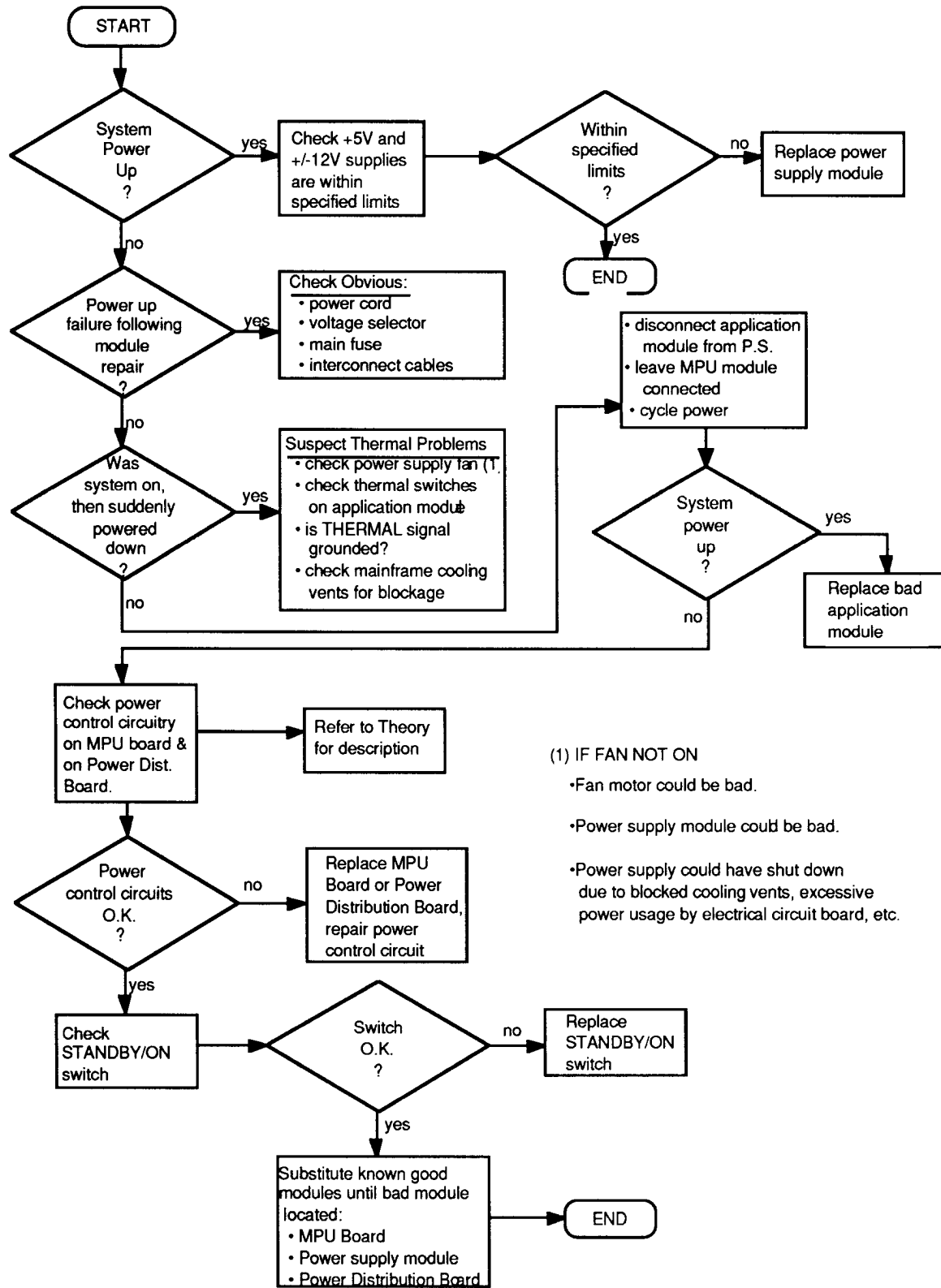

Figure 8-1. Power supply troubleshooting chart.

Troubleshooting Thermal Conditions

If air flow is insufficient, ambient temperature rises inside the mainframe enclosure. An over-temperature condition can be caused by any of the following:

- Cooling vent obstruction
- Fan failure
- Fan voltage too low
- Excessive drain on power supply

Some application modules use thermal switches to protect critical circuits on the module. If the ambient temperature exceeds the thermal rating of a switch, the switch will short to ground. This action grounds the THERM signal, shutting down the power supply via the power control circuit on the MPU board. Any application module connected to an MPU board can shut down the mainframe power supply in this manner. Figure 8-2 shows how a thermal switch is wire-ORed to the MPU's THERM signal line.

Refer to the applicable application module service manual for location of thermal switches. Once a suspected switch is located, cool it with cool spray and recycle power. If the system powers-up, then strongly suspect an excessive temperature problem. Check the problem further by ensuring that all cooling vents are cleared of obstructions before operating the instrument. If power supply fails again, suspect faulty circuitry. The thermal switch may be bad or circuitry in the area of the thermal switch may be using excessive power. Low-level troubleshooting is needed.

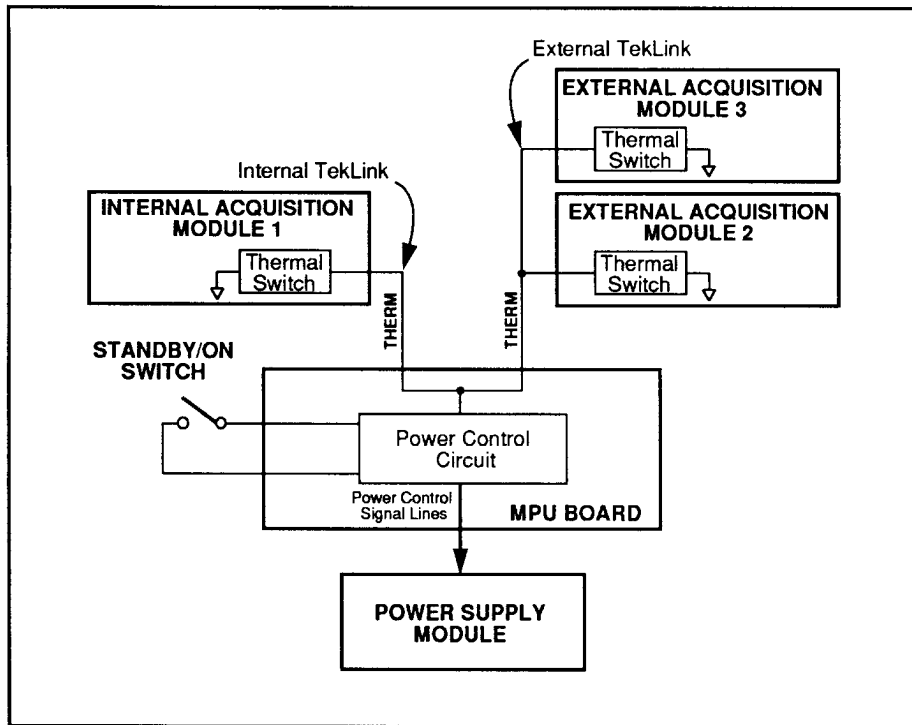

Figure 8-2. Thermal sensor wiring.

Keypad and Optional Keyboard Troubleshooting

If the keypad or keyboard works, but you suspect it is faulty (intermittent keys, etc.), refer to *Diagnostics Software* in the *MPU Board Service* manual. The Manual Keyboard routine in the diagnostic software produces a screen drawing of the keypad or optional keyboard. When a key is pressed, the corresponding screen key reverses video. Each key and the scrolling knob can be checked in this manner.

If the keypad or keyboard doesn't work at all, suspect either the interconnect cable, power, or the associated circuitry.

Cable

Refer to the Interconnect Diagram in the *Diagrams* section and check the appropriate interconnect cables for opens and shorts. If faulty, replace the cable. Refer to *Optional Keyboard Disassembly/Assembly* in Section 6 for keyboard cable replacement procedures.

Power

The keypad and optional keyboard receive +5 VDC power from the MPU board. Check the +5 V fuse on the MPU board and replace it if necessary. See the *MPU Board Service* manual for fuse location.

Disk Drive Troubleshooting

Diagnostic software provided with the MPU board provides low-level tests for both the floppy drive and floppy drive controller circuits on the MPU board. Refer to *Diagnostics Software* in the *MPU Board Service* manual for test descriptions.

The Floppy Disk drive receives power from the MPU board. Refer to the Floppy Drive Interconnect Diagram in the *Schematics* section for power cable routing and to the *MPU Board Service* manual for fuse locations.

If a drive unit failure is suspected, refer to the floppy drive description in the *Theory of Operations* section, this manual. With the information provided there and with the Interconnect Diagram, you can confirm whether the disk drive or interconnect cabling is at fault. If the disk drive unit is faulty, return the drive to Tektronix for repair and/or replacement.

CRT Display Monitor Troubleshooting

The CRT Display Module consists of the Display Driver board and the CRT. The Display Driver board receives power and control signals from the MPU board via the Connector Adapter board. To troubleshoot the CRT Display, perform the following:

- Exercise the video diagnostics included in the MPU board's diagnostic software. Refer to Section 9 in the *MPU Board Service* manual for instructions on how to exercise diagnostic software.
- Check the VID0, VID1, VID2, VID3, HSYNC, and VSYNC signals at the Video Driver board. Refer to Section 4 in the *MPU Board Service* manual for a description of CRT video operation.
- Check that +12 VDC power is available at the Display Driver board.
- Perform the CRT adjustment procedures described in Section 5 of this manual.
- If all signals and power to the Display Driver board are OK, but the CRT cannot be adjusted, then replace both the Display Driver board and the CRT. (Refer to Section 6 for disassembly/assembly procedures.) Alternatively, you can replace the Display Driver board and the CRT separately to isolate the problem to a specific module.
- After replacing the Display Driver board and/or the CRT, perform the display adjustment procedures listed in Section 5 of this manual.

Refer to *Section 4: Theory of Operation* for additional information about the CRT Display Module. Also, refer to *Section 4: Theory of Operation* in the *MPU Board Service* manual for a description of the MPU board's video controller circuitry with timing diagrams.

COMM Pack Troubleshooting

The diagnostics software provides tests for the various 1200-Series COMM Packs used with the mainframe's MPU board. Refer to Diagnostics Software in the *MPU Board Service* manual for detailed information. For COMM Pack component-level troubleshooting and repair information, refer to the 1240/1241 service manual.

The Theory of Operation Section in the *MPU Board Service* manual provides a detailed description of the MPU board's COMM Pack interface circuitry. That description will help you isolate a problem if interface circuitry is at fault.

COMM Packs receive +12 and -12 VDC power from the MPU board. Refer to the Interconnect Diagram for power interconnects and the *MPU Board Service* manual for fuse locations.

Section 9: REPLACEABLE ELECTRICAL PARTS

Parts Ordering Information

Replacement parts are available from or through your local Tektronix sales and service office or field representative.

When ordering parts, include the following information in your order: part number, instrument type or number, serial number, and modification number if applicable.

If a part you have ordered has been replaced with a new or improved part, your local Tektronix service center or field representative will contact you concerning any change in part number.

Change information, if any, is located at the rear of this manual.

List of Assemblies

A list of assemblies is given at the beginning of the Electrical Parts List. The assemblies are listed in numerical order. When the complete component number of a part is known, this list will identify the assembly in which the part is located.

Cross Index-Mfr Code Number to Manufacturer

The Mfr. Code Number to Manufacturer Cross Index for the Electrical Parts List is located immediately following this format information. The Cross Index provides codes, names and addresses for the manufacturers of components listed in the Electrical Parts List.

Abbreviations

Abbreviations in this section conform to American National Standard Y1.1.

Component Number (column 1)

Example a.

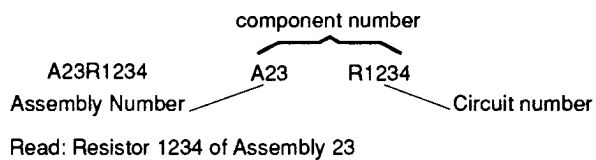

Example b.

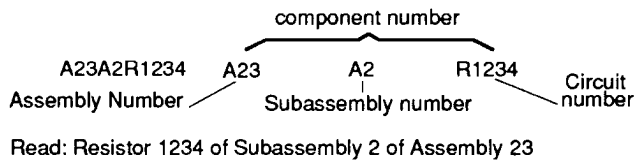

Replaceable Electrical Parts

The circuit component number appears on the diagrams and circuit board illustrations. Each diagram and circuit board illustration is clearly marked with the assembly number. Assembly numbers are also marked on the mechanical exploded views located in the mechanical parts list. The component number is obtained by adding the assembly number prefix to the circuit number.

The Electrical Parts List is divided and arranged by assemblies in numerical sequence (e.g., assembly A1 with its subassemblies and parts, precedes assembly A2 with its subassemblies and parts).

Chassis-mounted parts have no assembly number prefix and are located at the end of the Electrical Parts List.

Tektronix Part Number (column 2)	Indicates part number to be used when ordering replacement part from Tektronix.
Serial Number (columns 3 & 4)	Column three (3) indicates the serial number at which the part was first used. Column four (4) indicates the serial number at which the part was removed. No serial number indicates part is good for all serial numbers.
Name and Description (column 5)	In the Parts List, an Item Name is separated from the description by a colon(:). Because of space limitations, an Item Name may sometimes appear as incomplete. For further Item Name identification, the U.S. Federal Cataloging Handbook H6-1 can be utilized where possible.
Mfr. Code (column 6)	Indicates the code number of the actual manufacturer of the part. (Code to name and address cross reference can be found immediately after this page.)
Mfr. Part Number (column 7)	Indicates actual manufacturer's part number.

CROSS INDEX – MFR CODE NUMBER TO MANUFACTURER

Mfr Code	Manufacturer	Address	City, State, Zip Code
00222	ESC ELECTRONICS CORP	534 BERGEN BLVD	PALISADES PARK NJ 07650-2322
00779	AMP INC	2800 FULLING MILL	HARRISBURG PA 17105
01121	ALLEN-BRADLEY CO	1201 S 2ND ST	MILWAUKEE WI 53204-2410
01295	TEXAS INSTRUMENTS INC SEMICONDUCTOR GROUP	13500 N CENTRAL EXPY PO BOX 655012	DALLAS TX 75265
01961	VARIAN ASSOCIATES INC PULSE ENGINEERING SUBSIDIARY	7250 CONVOY CT P O BOX 12235	SAN DIEGO CA 92112
02113	COILCRAFT INC	1102 SILVER LAKE RD	CARY IL 60013-1658
03508	GENERAL ELECTRIC CO	W GENESEE ST	AUBURN NY 13021
04099	CAPCO INC	1328 WINTERS AVE	GRAND JUNCTION CO 81502
04222	AVX CERAMICS DIV OF AVX CORP	19TH AVE SOUTH P O BOX 867	MYRTLE BEACH SC 29577
04713	MOTOROLA INC	5005 E MCDOWELL RD	PHOENIX AZ 85008-4229
08779	INSILCO CORP	500 BAYVIEW AVE	INWOOD NY 11696-1702
09969	DALE ELECTRONICS INC	EAST HIGHWAY 50	YANKTON SD 57078
0J9R2	HARRISON ELECTRIC CO LTD	ASAHIMACHI 5-CHOME IMABARI	EHIME JAPAN
0J9R5	MARCON AMERICA CORP	3 PEARL COURT	ALLENTOWN NJ 07401
0JR03	ZMAN AND ASSOCIATES	7633 S 180th	KENT WA 98032
0JR04	TOSHIBA AMERICA INC	2692 DOW AVE	TUSTIN CA 92680
OKB01	STAUFFER SUPPLY	810 SE SHERMAN	PORTLAND OR 97214
11236	CTS CORP	406 PARR ROAD	BERNE IN 46711-9506
12300	POTTER AND BRUMFIELD DIV AMF CANADA LTD	52 ROYAL RD PO BOX 3620	GUELPH ONT CAN N1H 7H1
12954	MICROSEMI CORP - SCOTTSDALE	8700 E THOMAS RD	SCOTTSDALE AZ 85252
14301	ANDERSON ELECTRONICS INC	310 PENN ST	HOLLIDAYSBURG PA 16648-2009
14674	CORNING GLASS WORKS	HOUGHTON PK	CORNING NY 14830
17856	SILICONIX INC	2201 LAURELWOOD RD	SANTA CLARA CA 95054-1516
18324	SIGNETICS CORP	4130 S MARKET COURT	SACRAMENTO CA 95834-1222
18796	MURATA ERIE NORTH AMERICAN INC	1900 W COLLEGE AVE	STATE COLLEGE PA 16801-2723
19701	PHILIPS COMPONENTS DISCRETE PRODUCTS	PO BOX 760	MINERAL WELLS TX 76067-0760
1ES66	MAXIM INTEGRATED PRODUCTS INC	120 SAN GABRIEL DRIVE	SUNNYVALE CA 94086
1W344	UNITED CHEMI-CON INC	9801 W HIGGINS	ROSEMONT IL 60018-4704
1Y013	ACACIA/DEANCO	3101 SW 153RD DRIVE	BEAVERTON OR 97006
20933	KAPPA NETWORKS INC	765 ROOSEVELT AVE	CARTERET NJ 07008
22526	DU PONT E I DE NEMOURS AND CO INC	515 FISHING CREEK RD	NEW CUMBERLAND PA 17070-3007
23875	M-TRON INDUSTRIES INC	100 DOUGLAS ST	YANKTON SD 57078-4430
24355	ANALOG DEVICES INC	RT 1 INDUSTRIAL PK	NORWOOD MA 02062
24546	CORNING GLASS WORKS	550 HIGH ST	BRADFORD PA 16701-3737
24931	SPECIALTY CONNECTOR CO INC	2100 EARLYWOOD DR	FRANKLIN IN 46131
25088	SIEMENS CORP	186 WOOD AVE S	ISELIN NJ 08830-2704
25403	PHILIPS COMPONENTS DISCRETE PRODUCTS	GEORGE WASHINGTON HWY	SMITHFIELD RI 02917
26742	METHODE ELECTRONICS INC	7447 W WILSON AVE	CHICAGO IL 60656-4548
27014	NATIONAL SEMICONDUCTOR CORP	2900 SEMICONDUCTOR DR	SANTA CLARA CA 95051-0606
27264	MOLEX INC	2222 WELLINGTON COURT	LISLE IL 60532-1613
29454	JOHANSON DIELECTRICS INC	2210 SCREENLAND DR	BURBANK CA 91505-1137
31433	KEMET ELECTRONICS CORP	PO BOX 5928	GREENVILLE SC 29606
32997	BOURNS INC	1200 COLUMBIA AVE	RIVERSIDE CA 92507-2114

Replaceable Electrical Parts

CROSS INDEX – MFR CODE NUMBER TO MANUFACTURER

Mfr Code	Manufacturer	Address	City, State, Zip Code
34335	ADVANCED MICRO DEVICES	901 THOMPSON PL	SUNNYVALE CA 94086-4518
34371	HARRIS CORP HARRIS SEMICONDUCTOR PRODUCTS GROUP	200 PALM BAY BLVD PO BOX 883	MELBOURNE FL 32919
34899	FAIR-RITE PRODUCTS CORP	1 COMMERCIAL ROW	WALLKILL NY 12589
4T165	NEC ELECTRONICS USA INC ELECTRON DIV	401 ELLIS ST PO BOX 7241	MOUNTAIN VIEW CA 94039
50101	FREQUENCY SOURCES INC	16 MAPLE RD	CHELMSFORD MA 01824-3737
50434	HEWLETT-PACKARD CO	370 W TRIMBLE RD	SAN JOSE CA 95131
51791	STATEK CORP	512 N MAIN ST	ORANGE CA 92668-1102
52840	WESTERN DIGITAL CORP	3128 RED HILL AVE	COSTA MESA CA 92626-4525
53387	MINNESOTA MINING MFG CO	PO BOX 2963	AUSTIN TX 78769-2963
54331	MONITOR PRODUCTS CO INC	502 VIA DEL MONTE	OCEANSIDE CA 92054-1282
54583	TDK ELECTRONICS CORP	12 HARBOR PARK DR	PORT WASHINGTON NY 11550
55680	NICHICON /AMERICA/ CORP	927 E STATE PKY	SCHAUMBURG IL 60195-4526
56845	DALE ELECTRONICS INC	2300 RIVERSIDE BLVD	NORFOLK NE 68701-2242
57489	OHMTEK INC	2160 LIBERTY DR	NIAGARA FALLS NY 14304-3727
57668	ROHM CORP	8 WHATNEY	IRVINE CA 92713
59660	TUSONIX INC	7741 N BUSINESS PARK DR	TUCSON AZ 85740-7144
60705	CERA-MITE CORPORATION	1327 6TH AVE	GRAFTON WI 53024-1831
61058	MATSUSHITA ELECTRIC CORP OF AMERICA PANASONIC INDUSTRIAL CO DIV	ONE PANASONIC WAY PO BOX 1502	SECAUCUS NJ 07094-2917
61271	FUJITSU MICROELECTRONICS INC	2985 KIFER RD	SANTA CLARA CA 95051-0802
61429	FOX ELECTRONICS	PO BOX 1078	CAPE CORAL FL 33910-1078
61772	INTEGRATED DEVICE TECHNOLOGY	3236 SCOTT BLVD	SANTA CLARA CA 95051
61857	SAN-O INDUSTRIAL CORP	85 ORVILLE DR	BOHEMIA LONG ISLAND NY 11716-2501
61892	NEC ELECTRONICS USA INC MICROCOMPUTER DIVISION	1 NATICK EXECUTIVE PARK	NATICK MA 01760
63058	MCKENZIE TECHNOLOGY	44370 OLD WARMS SPRINGS BLVD	FREMONT CA 94538
63219	APPLIED MICRO CIRCUITS CORPORATION	5502 OBERLIN DR	SAN DIEGO CA 92121-1717
63791	STAR MICRONICS INC	200 PARK AVE	NEW YORK NY 10166-0001
64155	LINEAR TECHNOLOGY CORP	1630 MCCARTHY BLVD	MILPITAS CA 95035-7417
65786	CYPRESS SEMICONDUCTOR CORP	3901 N 1ST ST	SAN JOSE CA 95134-1506
66302	VLSI TECHNOLOGY INC	1109 MCKAY DR	SAN JOSE CA 95131-1706
71400	BUSSMANN DIV OF COOPER INDUSTRIES INC	114 OLD STATE RD PO BOX 14460	ST LOUIS MO 63178
71468	ITT CANNON	666 E DYER RD	SANTA ANA CA 92702
75378	CTS KNIGHTS INC	400 REIMANN AVE	SANDWICH IL 60548-1846
75915	LITTELFUSE INC	800 E NORTHWEST HWY	DES PLAINES IL 60016-3049
7W718	MARQUARDT SWITCHES INC	2711 ROUTH 20 EAST	CAZENOVIA NY 13035-1219
80009	TEKTRONIX INC	14150 SW KARL BRAUN DR	BEAVERTON OR 97077-0001
81073	GRAYHILL INC	561 HILLGROVE AVE	LA GRANGE IL 60525-5914
91637	DALE ELECTRONICS INC	2064 12TH AVE	COLUMBUS NE 68601-3632
95146	ALCO ELECTRONIC PRODUCTS INC	1551 OSGOOD ST	NORTH ANDOVER MA 01845-1014
S0167	FUJITSU LTD	2-3-13 TORANOMON	TOKYO JAPAN
TK0196	ALMAC-STROUM ELECTRONICS (DIST)	1885 NW 169TH PLACE	BEAVERTON OR 97006
TK0303	FAB TEK INC	17 SUGAR HOLLOW RD	DANBURY CT 06810
TK0875	MATSUO ELECTRONICS INC	831 S DOUBLAS ST	EL SEGUNDO CA 92641

CROSS INDEX – MFR CODE NUMBER TO MANUFACTURER

Mfr Code	Manufacturer	Address	City, State, Zip Code
TK1462	YAMAICHI ELECTRONICS CO LTD 2ND FLOOR NEW KYOEI	3-CHROME SHIBAURA MINATO-KU	TOKYO JAPAN
TK1465	BEAVERTON PARTS MFG CO	1800 NW 216TH AVE	HILLSBORO OR 97124-6629
TK1471	PHOENIX CONTACT INC	1900 GREENWOOD ST	HARRISBURG PA 17104
TK1864	INTERFET CORP	322 GOLD ST	GARLAND TX 75042
TK1900	TIME ELECTRONICS (DIST)	15688 SW 72ND AVENUE	PORTLAND OR 97223
TK2071	MOTOROLA	7402 S PRICE BLVD	TEMPE AZ 85282
TK2236	INTERNATIONAL IMPORTERS INC	5221 S MILLARD AVE	CHICAGO IL 60632

Replaceable Electrical Parts

Component No.	Tektronix Part Number	Serial Number Effect	Serial Number Discnt	Part Name & Description	Mfr Code	Mfr Part Number
A03	671-2696-00	B020100		CIRCUIT BD ASSY: IDE,HARD DISK,INTERFACE (3001GPX1M ONLY)	80009	671-2696-00
A03	671-2696-00	B020100		CIRCUIT BD ASSY: IDE,HARD DISK,INTERFACE (2505 ONLY)	80009	671-2696-00
A03	671-2696-00	B050100		CIRCUIT BD ASSY: IDE,HARD DISK,INTERFACE (3001MPX 1M ONLY)	80009	671-2696-00
A03	671-2696-00	B060100		CIRCUIT BD ASSY: IDE,HARD DISK,INTERFACE (3001HSM 1M ONLY)	80009	671-2696-00
A6	670-9664-01	B010100	B010260	CIRCUIT BD ASSY:HARD DISK CONTROLLER	80009	670-9664-01
A6	670-9664-01	B010283	B019999	CIRCUIT BD ASSY:HARD DISK CONTROLLER (3001MPX 1M ONLY)	80009	670-9664-01
A6	670-9664-02	B020100	B049999	CIRCUIT BD ASSY:HARD DISK CONTROLLER (3001MPX 1M ONLY)	80009	670-9664-02
A6	670-9664-01	B020164	B029999	CIRCUIT BD ASSY:HARD DISK CONTROLLER (3001HSM 1M ONLY)	80009	670-9664-01
A6	670-9664-02	B030100	B059999	CIRCUIT BD ASSY:HARD DISK CONTROLLER (3001HSM 1M ONLY)	80009	670-9664-02
A06	670-9664-02	B010261	B019999	CIRCUIT BD ASSY:HARD DISK CONTROLLER	80009	670-9664-02
A11	671-0070-02	B010100	B010156	CIRCUIT BD ASSY:30MPX,388-9512-XX WIRED	80009	671-0070-02
A11	671-0070-03	B010157		CIRCUIT BD ASSY:30MPX,388-9512-XX WIRED (3001MPX REFER TO 070-6677-XX FOR DETAILS)	80009	671-0070-03
A12	671-0071-02	B010100	B010107	CIRCUIT BD ASSY:30MPM,388-9513-XX WIRED (3001MPM ONLY)	80009	671-0071-02
A12	671-0071-03	B010108		CIRCUIT BD ASSY:30MPM,388-9512-XX WIRED (3001MPM REFER TO 070-6677-XX FOR DETAILS)	80009	671-0071-03
A13	671-0069-00	B010100	B010152	CIRCUIT BD ASSY:HSM	80009	
A13	671-0069-01	B010153	B010164	CIRCUIT BD ASSY:30HSM	80009	
A13	671-0069-02	B010165	B019999	CIRCUIT BD ASSY:30HSM	80009	671-0069-02
A13	671-0069-03	B020100	B020173	CIRCUIT BD ASSY:30HSM	80009	671-0069-03
A13	671-0069-04	B020174		CIRCUIT BD ASSY:30HSM (3001HSM REFERS TO 070-6677-XX FOR DETAILS)	80009	671-0069-04
A14	671-0058-51	B010100	B010113	CIRCUIT BD ASSY:MPU	80009	671-0058-51
A14	671-0058-52	B010114	B010125	CIRCUIT BD ASSY:MPU	80009	671-0058-52
A14	671-0058-53	B010126	B010128	CIRCUIT BD ASST:MPU	80009	671-0058-53
A14	671-0058-54	B010129		CIRCUIT BD ASSY:MPU (3001MPM) REFER TO 070-7413-XX FOR DETAILS	80009	671-0058-54
A14	671-0058-51	B010100	B010174	CIRCUIT BD ASSY:MPU	80009	671-0058-51
A14	671-0058-52	B010175	B010190	CIRCUIT BD ASSY:MPU	80009	671-0058-52
A14	671-0058-53	B010191	B010209	CIRCUIT BD ASST:MPU	80009	671-0058-53
A14	671-0058-54	B010210	B019999	CIRCUIT BD ASSY:MPU	80009	671-0058-54
A14	671-0058-55	B020100	B029999	CIRCUIT BD ASSY:MPU	80009	671-0058-55
A14	671-0058-56	B030100	B040104	CIRCUIT BD ASSY:MPU	80009	671-0058-56
A14	671-0058-57	B040105	B049999	CIRCUIT BD ASSY:MPU	80009	671-0058-57
A14	671-0058-58	B050100		CIRCUIT BD ASSY:MPU (3001MPX) REFER TO 070-7413-XX FOR DETAILS	80009	671-0058-58
A14	671-0058-52	B010100	B010140	CIRCUIT BD ASSY:MPU	80009	671-0058-52
A14	671-0058-53	B010141	B010159	CIRCUIT BD ASST:MPU	80009	671-0058-53
A14	671-0058-54	B010160	B029999	CIRCUIT BD ASSY:MPU (3001HSM ONLY)	80009	671-0058-54
A14	671-0058-56	B010100	B010169	CIRCUIT BD ASSY:MPU	80009	671-0058-56
A14	671-0058-57	B010170	B019999	CIRCUIT BD ASSY:MPU	80009	671-0058-57
A14	671-0058-58	B020100		CIRCUIT BD ASSY:MPU (3001GPX) REFER TO 070-7413-XX FOR DETAILS	80009	671-0058-58
A14	671-0058-54	B010100	B010248	CIRCUIT BD ASSY:MPU	80009	671-0058-54
A14	671-0058-55	B010249	B010281	CIRCUIT BD ASSY:MPU	80009	671-0058-55
A14	671-0058-56	B010282	B010287	CIRCUIT BD ASSY:MPU	80009	671-0058-56
A14	671-0058-57	B010288	B019999	CIRCUIT BD ASSY:MPU	80009	671-0058-57
A14	671-0058-58	B020100		CIRCUIT BD ASSY:MPU (2505 ONLY)	80009	671-0058-58
A14	671-0058-55	B030100	B039999	CIRCUIT BD ASSY:MPU	80009	671-0058-55
A14	671-0058-56	B040100	B049999	CIRCUIT BD ASSY:MPU	80009	671-0058-56
A14	671-0058-57	B050100	B059999	CIRCUIT BD ASSY:MPU	80009	671-0058-57
A14	671-0058-58	B060100		CIRCUIT BD ASSY:MPU (3001HSM) REFER TO 070-7413-XX FOR DETAILS	80009	671-0058-58
A15	671-1371-00			CIRCUIT BD ASSY:3001MPX CONNECTOR	80009	671-1371-00
A16	671-1372-00			CIRCUIT BD ASSY:3001MPX KEYBOARD	80009	671-1372-00

Replaceable Electrical Parts

Component No.	Tektronix Part Number	Serial Number Effect Discnt	Part Name & Description	Mfr Code	Mfr Part Number	
A17	671-1373-00	B010100	B039999	CIRCUIT BD ASSY:3001MPX PWR	80009	671-1373-00
A17	671-1373-01	B040100		CIRCUIT BD ASSY:3001MPX PWR (3001HSM) REFER TO 070-7413-XX FOR DETAILS	80009	671-1373-01
A17	671-1373-00	B010100	B039999	CIRCUIT BD ASSY:3001MPX PWR	80009	671-1373-00
A17	671-1373-01	B040100		CIRCUIT BD ASSY:3001MPX PWR (3001MPX) REFER TO 070-7413-XX FOR DETAILS	80009	671-1373-01
A17	671-1373-00	B010100	B010293	CIRCUIT BD ASSY:3001MPX PWR	80009	671-1373-00
A17	671-1373-01	B010294		CIRCUIT BD ASSY:3001MPX PWR (2505) REFER TO 070-7413-XX FOR DETAILS	80009	671-1373-01

Replaceable Electrical Parts

Component No.	Tektronix Part Number	Serial Number Effect	Serial Number Discnt	Part Name & Description	Mfr Code	Mfr Part Number
A03	671-2696-00	B020100		CIRCUIT BD ASSY: IDE,HARD DISK,INTERFACE (3001GPX 1M ONLY)	80009	671-2696-00
A03	671-2696-00	B020100		CIRCUIT BD ASSY: IDE,HARD DISK,INTERFACE (2505 ONLY)	80009	671-2696-00
A03	671-2696-00	B050100		CIRCUIT BD ASSY: IDE,HARD DISK,INTERFACE (3001MPX 1M ONLY)	80009	671-2696-00
A03	671-2696-00	B060100		CIRCUIT BD ASSY: IDE,HARD DISK,INTERFACE (3001HSM 1M ONLY)	80009	671-2696-00
A03C263	281-0913-00			CAP,FXD,CER DI:0.1UF,50V,AXIAL	04222	SA105E104ZAA
A03C370	290-0747-00			CAP,FXD,ELCTLT:100UF,+50-20%,25WVDC	1W344	SME25T101M6X16LL
A03C450	281-0913-00			CAP,FXD,CER DI:0.1UF,50V,AXIAL	04222	SA105E104ZAA
A03DS350	150-1161-00			LT EMITTING DIO:YELLOW	50434	QLMP-1487
A03J290	131-5528-00			CONN,HDR:PCB,MALE,STR,2 X 22,2MM CTR,0.5MM	22526	87131-344
A03J510	131-3520-00			CONN,HDR:PCB,MALE,STR,2 X 5,0.1 CTR,0.365	53387	2510-6002UB
A03J560	131-3323-00			CONN,HDR:PCB,MALE,STR,2 X 20,0.1 CTR,0.365	22526	66506-025
A03R260	315-0103-00			RES,FXD,FILM:10K OHM,5%,0.25W	19701	5043CX10K00J
A03R261	315-0103-00			RES,FXD,FILM:10K OHM,5%,0.25W	19701	5043CX10K00J
A03R262	315-0103-00			RES,FXD,FILM:10K OHM,5%,0.25W	19701	5043CX10K00J
A03R264	315-0103-00			RES,FXD,FILM:10K OHM,5%,0.25W	19701	5043CX10K00J
A03R360	315-0102-00			RES,FXD,FILM:1K OHM,5%,0.25W	57668	NTR25JE01K0
A03R361	315-0103-00			RES,FXD,FILM:10K OHM,5%,0.25W	19701	5043CX10K00J
A03R362	315-0300-00			RES,FXD,FILM:30 OHM,5%,0.25W	19701	5043CX30R00J
A03R363	315-0300-00			RES,FXD,FILM:30 OHM,5%,0.25W	19701	5043CX30R00J
A03R364	315-0300-00			RES,FXD,FILM:30 OHM,5%,0.25W	19701	5043CX30R00J
A03R365	315-0300-00			RES,FXD,FILM:30 OHM,5%,0.25W	19701	5043CX30R00J
A03U451	160-9200-00			IC,DIGITAL:CMOS,PLD:PLD,16V8,PRGM	80009	160-9200-00
A6	670-9664-01	B010100	BOXXXX	CIRCUIT BD ASSY:HARD DISK CONTROLLER	80009	670-9664-01
A6	670-9664-02	BOXXXX	B019999	CIRCUIT BD ASSY:HARD DISK CONTROLLER (2505 ONLY)	80009	670-9664-02
A6	670-9664-01	B010283	B019999	CIRCUIT BD ASSY:HARD DISK CONTROLLER	80009	670-9664-01
A6	670-9664-02	B020100	B049999	CIRCUIT BD ASSY:HARD DISK CONTROLLER (3001MPX 1M ONLY)	80009	670-9664-02
A6	670-9664-01	B020164	B029999	CIRCUIT BD ASSY:HARD DISK CONTROLLER	80009	670-9664-01
A6	670-9664-02	B030100	B059999	CIRCUIT BD ASSY:HARD DISK CONTROLLER (3001HSM 1M ONLY)	80009	670-9664-02
A6	670-9664-01	B010100	B010260	CIRCUIT BD ASSY:HARD DISK CONTROLLER	80009	670-9664-01
A6	670-9664-02	B010261	B019999	CIRCUIT BD ASSY:HARD DISK CONTROLLER (3001GPX 1M ONLY)	80009	670-9664-02
A6C100	281-0913-00			CAP,FXD,CER DI:0.1UF,50V,AXIAL	04222	SA105E104ZAA
A6C110	281-0913-00			CAP,FXD,CER DI:0.1UF,50V,AXIAL	04222	SA105E104ZAA
A6C112	281-0913-00	B010853		CAP,FXD,CER DI:0.1UF,50V,AXIAL	04222	SA105E104ZAA
A6C114	281-0765-00	B010853		CAP,FXD,CER DI:100PF,5%,100V	04222	SA102A101JAA
A6C116	281-0913-00	B010853		CAP,FXD,CER DI:0.1UF,50V,AXIAL	04222	SA105E104ZAA
A6C120	283-0084-02	B010853		CAP,FXD,CER DI:270PF,5%,1000V	60705	562CRE102EF271JA07
A6C130	283-0341-00	B010853		CAP,FXD,CER DI:0.047UF,10%,100V	04222	SR301C473KAA
A6C132	283-0167-00	B010853		CAP,FXD,CER DI:0.1UF,10%,100V	04222	SR211C104KAA
A6C134	281-0913-00	B010853		CAP,FXD,CER DI:0.1UF,50V,AXIAL	04222	SA105E104ZAA
A6C136	285-1036-00	B010853		CAP,FXD,PLASTIC:0.2UF,20%,2000V	04099	TEK-18
A6C150	281-0913-00			CAP,FXD,CER DI:0.1UF,50V,AXIAL	04222	SA105E104ZAA
A6C160	281-0913-00			CAP,FXD,CER DI:0.1UF,50V,AXIAL	04222	SA105E104ZAA
A6C180	281-0913-00	B010853		CAP,FXD,CER DI:0.1UF,50V,AXIAL	04222	SA105E104ZAA
A6C190	281-0913-00	B010853		CAP,FXD,CER DI:0.1UF,50V,AXIAL	04222	SA105E104ZAA
A6C200	281-0913-00	B010853		CAP,FXD,CER DI:0.1UF,50V,AXIAL	04222	SA105E104ZAA
A6C210	281-0913-00	B010853		CAP,FXD,CER DI:0.1UF,50V,AXIAL	04222	SA105E104ZAA
A6C290	290-1075-00	B010853		CAP,FXD,ELCTLT:47UF,16V	1W344	KMC16VB47RM6X11LL
A6C300	281-0913-00	B010853		CAP,FXD,CER DI:0.1UF,50V,AXIAL	04222	SA105E104ZAA
A6C310	281-0913-00			CAP,FXD,CER DI:0.1UF,50V,AXIAL	04222	SA105E104ZAA

Replaceable Electrical Parts

Component No.	Tektronix Part Number	Serial Number Effect	Discont	Part Name & Description	Mfr Code	Mfr Part Number
A6C320	281-0913-00	B010853		CAP,FXD,CER DI:0.1UF,50V,AXIAL	04222	SA105E104ZAA
A6C330	281-0913-00			CAP,FXD,CER DI:0.1UF,50V,AXIAL	04222	SA105E104ZAA
A6C360	281-0913-00			CAP,FXD,CER DI:0.1UF,50V,AXIAL	04222	SA105E104ZAA
A6C380	281-0913-00	B010853		CAP,FXD,CER DI:0.1UF,50V,AXIAL	04222	SA105E104ZAA
A6C390	281-0913-00	B010853		CAP,FXD,CER DI:0.1UF,50V,AXIAL	04222	SA105E104ZAA
A6C395	281-0913-00	B010853		CAP,FXD,CER DI:0.1UF,50V,AXIAL	04222	SA105E104ZAA
A6C400	281-0913-00	B010853		CAP,FXD,CER DI:0.1UF,50V,AXIAL	04222	SA105E104ZAA
A6C420	281-0913-00			CAP,FXD,CER DI:0.1UF,50V,AXIAL	04222	SA105E104ZAA
A6C430	281-0913-00			CAP,FXD,CER DI:0.1UF,50V,AXIAL	04222	SA105E104ZAA
A6C440	281-0913-00	B010853		CAP,FXD,CER DI:0.1UF,50V,AXIAL	04222	SA105E104ZAA
A6C480	281-0913-00	B010853		CAP,FXD,CER DI:0.1UF,50V,AXIAL	04222	SA105E104ZAA
A6C495	281-0913-00	B010853		CAP,FXD,CER DI:0.1UF,50V,AXIAL	04222	SA105E104ZAA
A6DL310	119-1825-00	B010853		DELAY LINE,ELEC:6ONS,TAPPED,14 DIP	00222	14TD60
A6J190	131-4303-00	B010100	B020279	CONN,HDR:PCB,:MALE,STR,2 X 5,0.1 CTR,0.520	22526	65692-001
A6J190	131-3520-00	B020280		CONN,HDR:PCB,:MALE,STR,2 X 5,0.1 CTR,0.365	53387	2510-6002UB
A6J200	131-4304-00	B010100	B020279	CONN,HDR:PCB,:MALE,STR,2 X 10,0.1 CTR	22526	65692-007
A6J200	131-3360-00	B020280		CONN,HDR:PCB,:MALE,STR,2 X 10,0.1 CTR,0.365	53387	2520-6002UB
A6J390	131-4306-00	B010100	B020279	CONN,HDR:PCB,:MALE,STR,2 X 20,0.1 CTR	22526	65692-025
A6J390	131-3323-00	B020280		CONN,HDR:PCB,:MALE,STR,2 X 20,0.1 CTR,0.365	22526	66506-025
A6J400	131-4305-00	B010100	B020239	CONN,HDR:PCB,:MALE,STR,2 X 17,0.1 CTR	22526	65692-019
A6J400	131-3364-00	B020240		CONN,HDR:PCB,:MALE,STR,2 X 17,0.1 CTR,0.365	53387	2534-6002UB
A6R100	315-0101-00	B010853		RES,FXD,FILM:100 OHM,5%,0.25WS	57668	NTR25J-E 100E
A6R110	321-0258-01	B010853		RES,FXD,FILM:4.75K OHM,0.5%,0.125W,TC=TO	19701	5033RD4K750D
A6R111	315-0821-00	B010853		RES,FXD,FILM:820 OHM,5%,0.25W	19701	5043CX820ROJ
A6R112	315-0821-00	B010853		RES,FXD,FILM:820 OHM,5%,0.25W	19701	5043CX820ROJ
A6R113	321-0193-01	B010853		RES,FXD,FILM:1K OHM,0.5%,0.125W,TC=TOMI	19701	5033RD1K000F
A6R130	315-0111-00	B010853		RES,FXD,FILM:110 OHM,5%,0.25W	57668	NTR25J-E110E
A6R190	315-0102-00	B010853		RES,FXD,FILM:1K OHM,5%,0.25W	57668	NTR25JE01K0
A6R220	315-0151-00	B010853		RES,FXD,FILM:150 OHM,5%,0.25W	57668	NTR25J-E150E
A6R222	315-0470-00	B010853		RES,FXD,FILM:47 OHM,5%,0.25W	57668	NTR25J-E47E0
A6R260	315-0102-00	B010853		RES,FXD,FILM:1K OHM,5%,0.25W	57668	NTR25JE01K0
A6R262	315-0102-00	B010853		RES,FXD,FILM:1K OHM,5%,0.25W	57668	NTR25JE01K0
A6R264	315-0471-00	B010853		RES,FXD,FILM:470 OHM,5%,0.25W	57668	NTR25J-E470E
A6R340	315-0102-00	B010853		RES,FXD,FILM:1K OHM,5%,0.25W	57668	NTR25JE01K0
A6R370	315-0471-00	B010853		RES,FXD,FILM:470 OHM,5%,0.25W	57668	NTR25J-E470E
A6R372	315-0102-00	B010853		RES,FXD,FILM:1K OHM,5%,0.25W	57668	NTR25JE01K0
A6R380	315-0102-00	B010853		RES,FXD,FILM:1K OHM,5%,0.25W	57668	NTR25JE01K0
A6R382	315-0102-00	B010853		RES,FXD,FILM:1K OHM,5%,0.25W	57668	NTR25JE01K0
A6R400	307-0993-00			RES NTWK,FXD,FI:330/390 OHM,10 DIP	91637	CSC10A-05-330/390G
A6R470	307-0540-00	B010853		RES NTWK,FXD,FI:(5)1K OHM,2%,0.7W	91637	CSC06A01-102G-D03
A6R472	315-0102-00	B010853		RES,FXD,FILM:1K OHM,5%,0.25W	57668	NTR25JE01K0
A6U100	156-1315-00			IC,DIGITAL:LSTTL,BUFFER;QUAD DIFFERENTIAL	27014	DS26LS32(N OR J)
A6U120	156-2030-01	B010853		IC,LINEAR:BIPOLAR,DATA SEPARATOR;HARD DISK	27014	DP8465-M
A6U150	156-1611-00	B010853		IC,DIGITAL:FTTL,FLIP FLOP;DUAL D-TYPE;74F74	04713	MC74F74N
A6U160	156-1756-00	B010853		IC,DIGITAL:ALSTTL,FLIP FLOP;DUAL D-TYPE	01295	SN74ALS74A (N OR J)
A6U170	156-2389-00	B010853		IC,DIGITAL:ASTTL,COUNTER;SYNCH 8-BIT	01295	SN74AS867NT
A6U180	156-2066-00	B010853		IC,MEMORY:CMOS,SRAM;8K X 8,120NS; ,DIP28.3	61271	MB8464-12P
A6U190	156-2066-00	B010853		IC,MEMORY:CMOS,SRAM;8K X 8,120NS; ,DIP28.3	61271	MB8464-12P
A6U200	156-1681-00	B010853		IC,DIGITAL:LSTTL,DRIVER;QUAD DIFFERENTIAL	27014	DS26LS31CN
A6U210	156-0994-00	B010853		IC,DIGITAL:LSTTL,MUX/ENCODER:8-TO-1, T&F	01295	SN74LS151N
A6U300	156-0467-00	B010853		IC,DIGITAL:LSTTL,GATES;QUAD 2-INPUT NAND	01295	SN74LS38N
A6U320	156-0392-00	B010853		IC,DIGITAL:LSTTL,FLIP FLOP;QUAD D W/CLR	01295	SN74LS175N
A6U330	156-1722-00	B010853		IC,DIGITAL:FTTL,GATE;HEX INV;74F04,DIP14.3	04713	MC74F04N
A6U340	160-5236-00	B010853		IC,DIGITAL:STTL,PLD;PAL,16R4,25MHZ,180MA	80009	160-5236-00
A6U350	160-5235-00	B010853		IC,DIGITAL:STTL,PLD;PAL,20L8,25NS,210MA	80009	160-5235-00
A6U360	156-2148-00	B010853		IC,PROCESSOR:NMOS,PERIPHERAL;HARD DISK	52840	WD2010B-05
A6U380	156-0844-00	B010853		IC,DIGITAL:LSTTL,COUNTER;SYNCH 4-BIT BINARY	01295	SN74LS161AN
A6U390	156-1111-00	B010853		IC,DIGITAL:LSTTL,TRANSCEIVER;OCTAL NONINV,	01295	SN74LS245N

Replaceable Electrical Parts

Component No.	Tektronix Part Number	Serial Number Effect	Discont	Part Name & Description	Mfr Code	Mfr Part Number
A6J395	156-1111-00	B010853		IC,DIGITAL:LSTTL,TRANSCEIVER;OCTAL NONINV,	01295	SN74LS245N
A6J400	156-0645-00			IC,DIGITAL:LSTTL,GATES;HEX INV, W/SCHMITT	01295	SN74LS14N
A6J420	156-0467-00	B010853		IC,DIGITAL:LSTTL,GATES;QUAD 2-INPUT NAND	01295	SN74LS38N
A6J430	156-0865-00	B010853		IC,DIGITAL:LSTTL,FLIP FLOP;OCTAL D-TYPE,	01295	SN74LS273N
A6J440	156-0383-00	B010853		IC,DIGITAL:LSTTL,GATES;QUAD 2-INPUT NOR	01295	SN74LS02N
A6J450	156-0382-00	B010853		IC,DIGITAL:LSTTL,GATE;QUAD 2-INPUT NAND	01295	SN74LS00N
A6J480	156-0392-00	B010853		IC,DIGITAL:LSTTL,FLIP FLOP;QUAD D W/CLR	01295	SN74LS175N
A6J495	156-1111-00	B010853		IC,DIGITAL:LSTTL,TRANSCEIVER;OCTAL NONINV,	01295	SN74LS245

Replaceable Electrical Parts

Component No.	Tektronix		Serial Number		Part Name & Description	Mfr Code	Mfr Part Number
	Part Number	Effect	Discont				
A15	671-1371-00	B010100	B039999		CIRCUIT BD ASSY:3001MPX CONNECTOR	80009	671-1371-00
A15	671-1371-01	B040100			CIRCUIT BD ASSY:3001MPX CONNECTOR (3001HSM ONLY)	80009	671-1371-01
A15	671-1371-00	B010100	B039999		CIRCUIT BD ASSY:3001MPX CONNECTOR	80009	671-1371-00
A15	671-1371-01	B040100			CIRCUIT BD ASSY:3001MPX CONNECTOR (3001MPX 1M ONLY)	80009	671-1371-01
A15	671-1371-00	B010100	B010293		CIRCUIT BD ASSY:3001MPX CONNECTOR	80009	671-1371-00
A15	671-1371-01	B010294			CIRCUIT BD ASSY:3001MPX CONNECTOR (2505 ONLY)	80009	671-1371-01
A15	671-1371-01				CIRCUIT BD ASSY:3001MPX CONNECTOR (3001GPX 1M ONLY)	80009	671-1371-01
A15C140	281-0563-00				CAP,FXD,CER DI:0.47UF,20%,50V	04222	SA305E474MAA
A15C235	281-0786-00				CAP,FXD,CER DI:150PF,10%,100V	04222	SA101A151KAA
A15C236	281-0786-00				CAP,FXD,CER DI:150PF,10%,100V	04222	SA101A151KAA
A15C245	281-0786-00				CAP,FXD,CER DI:150PF,10%,100V	04222	SA101A151KAA
A15CR130	152-0886-00				SEMICON DVC,DI:SI,1A,600V,35NS	04713	MUR160RL
A15CR131	152-0886-00				SEMICON DVC,DI:SI,1A,600V,35NS	04713	MUR160RL
A15CR135	152-0886-00				SEMICON DVC,DI:SI,1A,600V,35NS	04713	MUR160RL
A15CR136	152-0886-00				SEMICON DVC,DI:SI,1A,600V,35NS	04713	MUR160RL
A15CR150	152-0886-00				SEMICON DVC,DI:SI,1A,600V,35NS	04713	MUR160RL
A15CR151	152-0886-00				SEMICON DVC,DI:SI,1A,600V,35NS	04713	MUR160RL
A15J100	136-1083-00				SKT,PIN TERM:0.018 PIN	63058	CBU-GG-0552-1
A15J150	136-1083-00				SKT,PIN TERM:0.018 PIN	63058	CBU-GG-0552-1
A15J200	131-4302-00				CONN,HDR:PCB,;MALE,RTANG,2 X 13,0.1 CTR	22526	65496-148
A15J250	131-4855-00				CONN,HDR:PCB,;MALE,RTANG,2 X 10,0.1 CTR	22526	65496-093
A15R203	315-0221-00				RES,FXD,FILM:220 OHM,5%,0.25W	57668	NTR25J-E220E
A15R204	315-0200-00				RES,FXD,FILM:20 OHM,5%,0.25W	19701	5043CX20R00J
A15R205	315-0200-00				RES,FXD,FILM:20 OHM,5%,0.25W	19701	5043CX20R00J
A15R206	315-0221-00				RES,FXD,FILM:220 OHM,5%,0.25W	57668	NTR25J-E220E
A15R231	315-0111-00				RES,FXD,FILM:110 OHM,5%,0.25W	57668	NTR25J-E110E
A15R238	131-0566-00				BUS,CONDUCTOR:DUMMY RES,0.094 OD X 0.225L	24546	QMA 07
A15R250	315-0111-00				RES,FXD,FILM:110 OHM,5%,0.25W	57668	NTR25J-E110E
A15TP260	131-1425-00				CONN,HDR:PCB,;MALE,RTANG,1 X 36,0.1 CTR	22526	65521-136

Replaceable Electrical Parts

Component No.	Tektronix	Serial Number		Part Name & Description	Mfr	Mfr Part Number
	Part Number	Effect	Discont		Code	
A16	671-1372-00			CIRCUIT BD ASSY:3001MPX KEYBOARD	80009	671-1372-00
A16C100	281-0812-00			CAP,FXD,CER DI:1000PF,10%,100V	04222	SA101C102KAA
A16C105	281-0864-00			CAP,FXD,CER DI:430PF,5%,100V	04222	SA101A431JAA
A16C130	281-0864-00			CAP,FXD,CER DI:430PF,5%,100V	04222	SA101A431JAA
A16C200	281-0913-00			CAP,FXD,CER DI:0.1UF,50V,AXIAL	04222	SA105E104ZAA
A16C235	281-0913-00			CAP,FXD,CER DI:0.1UF,50V,AXIAL	04222	SA105E104ZAA
A16C240	281-0913-00			CAP,FXD,CER DI:0.1UF,50V,AXIAL	04222	SA105E104ZAA
A16C405	281-0864-00			CAP,FXD,CER DI:430PF,5%,100V	04222	SA101A431JAA
A16J120	131-0608-00			TERMINAL,PIN:PRESSFIT/PCB,;MALE,STR,0.025	22526	48283-036
A16J120	131-3971-00			CONN,RCPT,ELEC:2 X 3,LATCH & LOCK	22526	79047-105
A16J220	131-0608-00			TERMINAL,PIN:PRESSFIT/PCB,;MALE,STR,0.025	22526	48283-036
A16J320	131-4916-00			CONN,HDR,:PCB,;MALE,STR,2 X 3,0.1 CTR,0.120	22526	69168-106
A16L205	276-0818-00			COIL,EM:100MHZ,FERRITE,BEAD ON LEAD, IMP:	34899	2743003112
A16L300	276-0818-00			COIL,EM:100MHZ,FERRITE,BEAD ON LEAD, IMP:	34899	2743003112
A16R135	315-0560-00			RES,FXD,FILM:56 OHM,5%,0.25W	57668	NTR25J-E56E0
A16R140	315-0202-00			RES,FXD,FILM:2K OHM,5%,0.25W	57668	NTR25J-E 2K
A16R230	315-0471-00			RES,FXD,FILM:470 OHM,5%,0.25W	57668	NTR25J-E470E
A16R305	315-0202-00			RES,FXD,FILM:2K OHM,5%,0.25W	57668	NTR25J-E 2K
A16R310	315-0202-00			RES,FXD,FILM:2K OHM,5%,0.25W	57668	NTR25J-E 2K
A16R325	315-0471-00			RES,FXD,FILM:470 OHM,5%,0.25W	57668	NTR25J-E470E
A16U235	156-0530-00			IC,DIGITAL:LSTTL,MUX:QUAD 2-TO-1, DATA	01295	SN74LS157N

Replaceable Electrical Parts

Component No.	Tektronix		Serial Number		Part Name & Description	Mfr Code	Mfr Part Number
	Part Number	Effect	Discont				
A17	671-1373-00				CIRCUIT BD ASSY:3001MPX PWR	80009	671-1373-00
A17C235	290-0844-00				CAP,FXD,ELCTLT:100UF,+75-20%,35WVDC	1W344	SM63VB101M10X20LL
A17C322	281-0563-00				CAP,FXD,CER DI:0.47UF,20%,50V	04222	SA305E474MAA
A17C520	290-0770-00				CAP,FXD,ELCTLT:100UF,+50-20%,25VDC	1W344	SL50VB101M10X16LL
A17C540	281-0775-00				CAP,FXD,CER DI:0.1UF,20%,50V	04222	SA105E104MAA
A17C550	281-0775-00				CAP,FXD,CER DI:0.1UF,20%,50V	04222	SA105E104MAA
A17CR427	152-0066-00				DIODE,RECT:;,400V,1A,IFSM = 30A:GP10G,DO-41	25403	1N5060
A17CR428	152-0066-00				DIODE,RECT:;,400V,1A,IFSM = 30A:GP10G,DO-41	25403	1N5060
A17F330	159-0194-00				FUSE,WIRE LEAD:5A,125V,0.125 SECS	61857	SP5-5A LEAD TAPE REE
A17F350	159-0194-00				FUSE,WIRE LEAD:5A,125V,0.125 SEC	61857	SP5-5A LEAD TAPE REE
A17J110	131-4963-00				CONN,HDR:PCB,;MALE,STR,1 X 2,0.1 CTR,0.535	00779	103908-1
A17J120	131-3871-00				CONN,HDR PWR:PCB,;MALE,STR,1 X 5,0.156 CTR	27264	26-48-2055
A17J130	131-2427-01				TERM,QIK DISC.:PCB,;MALE TAB,0.250 X 0.032	00779	62650-1
A17J150	131-2427-01				TERM,QIK DISC.:PCB,;MALE TAB,0.250 X 0.032	00779	62650-1
A17J310	131-2427-01				TERM,QIK DISC.:PCB,;MALE TAB,0.250 X 0.032	00779	62650-1
A17J410	131-4906-00				CONN,HDR PWR:;PCB,;MALE,STR,1 X 4,0.156 CTR	TK1900	26-48-2045 W/CIRCUIT
A17J530	131-2427-01				TERM,QIK DISC.:PCB,;MALE TAB,0.250 X 0.032	00779	62650-1
A17J540	131-4799-00				CONN,HDR:PCB,;MALE,RTANG,1 X 2,0.1 CTR,0.3	00779	103904-1
A17J550	131-4799-00				CONN,HDR:PCB,;MALE,RTANG,1 X 2,0.1 CTR,0.3	00779	103904-1
A17K210	148-1017-00				RELAY,ARMATURE:2 FORM C,10A,240VAC,COIL	12300	KUIP-11D55-12
A17Q325	151-0254-00				TRANSISTOR,SIG:BIPOLAR,NPN:30V,500MA,125MHZ	04713	MPSA14
A17R240	307-0057-00				RES,FXD,CMPSN:5.1 OHM,5%,0.5W	01121	EB51G5
A17R320	315-0100-00				RES,FXD,FILM:10 OHM,5%,0.25W	19701	5043CX10RROOJ
A17R340	307-0103-00				RES,FXD,CMPSN:2.7 OHM,5%,0.25W	01121	CB27G5
A17R350	307-0103-00				RES,FXD,CMPSN:2.7 OHM,5%,0.25W	01121	CB27G5
A17R426	315-0153-00				RES,FXD,FILM:15K OHM,5%,0.25W	19701	5043CX15KROOJ
A17T320	120-1853-00				XPMR,PWR,STU:115/230V,50/60HZ INPUT	08779	LP 10-250-CSA
CHASSIS PARTS							
F100	159-0015-00				FUSE, CARTRIDGE:3AG,3A,250V,0.65 SEC (STANDARD, 115V OPERATION)	71400	AGC-CW-3
F100	159-0021-00				FUSE, CARTRIDGE:3AG,2A,250V,FAST BLOW (OPTION A1,A2,A3,A5, 230V OPERATION)	71400	AGC-CW-2
J100	119-3745-00				FILTER,RFD:LINE,3A,250V,PANEL MOUNT	TK0196	119-3745-00
S100	260-2501-00				SWITCH,ROCKER:DPDT,6 AMP,250VAC	7W718	1804.1153
S102	260-1967-00				SWITCH,SLIDE:DPDT,5A/250V,10A/115V	7W718	4021.0512

DIAGRAMS AND CIRCUIT BOARD ILLUSTRATION

SYMBOLS

Graphic symbol and class designation letters are based on ANSI Y32.14, 1973 in terms of positive logic. Logic symbols are depicted according to the manufacturer's data book information (not according to function).

Letter symbols for quantities used in electrical science and electrical engineering are based on ANSI Y10.5, 1968.

Drafting practices, line conventions, and lettering conform to ANSI Y14.12, 1966 and ANSI Y14.2, 1973.

Abbreviations are based on ANSI Y1.1, 1972.

You can inquire about these ANSI standards by contacting:

American National Standard Institute
1430 Broadway
New York, New York 10018

The information and special symbols below may appear in this manual.

ASSEMBLY NUMBERS

Each assembly in the instrument is assigned an assembly number e.g., A5). The assembly number appears in the title of each:

- schematic diagram (lower right corner)
- circuit board component location look up table (when shown)
- schematic or circuit board component location look up table (when shown)

The Replaceable Electrical Parts list is arranged by assemblies in numerical order. The components are listed alphabetically by component location numbers. Look at the following example to see how to construct a component number.

COMPONENT VALUES

Electrical components shown on the diagram are in the following units unless noted otherwise:

Capacitors = Values one or greater are in picofarads (pF)
Values less than one are in microfarads (μF)

Resistors = Ohms (Ω)

ACTIVE-LOW SIGNAL INDICATORS

A common convention used for indicating an active-low signal (a signal performing its intended function when it is in a low state) is an overbar, as shown in the signal name RESET. The overbar may be used in this manual whenever a reference is given to an active-low signal. However, the same active-low signal is indicated on the schematic with a tilde (~), or a pound sign (#) following the signal name (e.g., RESET ~ or RESET#).

COMPONENT NUMBER EXAMPLE

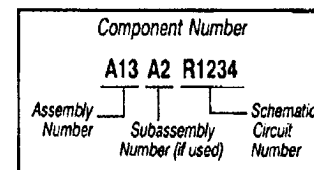

Chassis mounted components have no Assembly Number prefix - see end of Replaceable Parts List.

GRID COORDINATES

The schematic diagram(s) and circuit board component location illustration both have grids. A look up table (when shown) provides grid coordinates for ease of locating components. There may be two tables for each assembly: one for the circuit board component location illustration, and one for the schematic diagram(s).

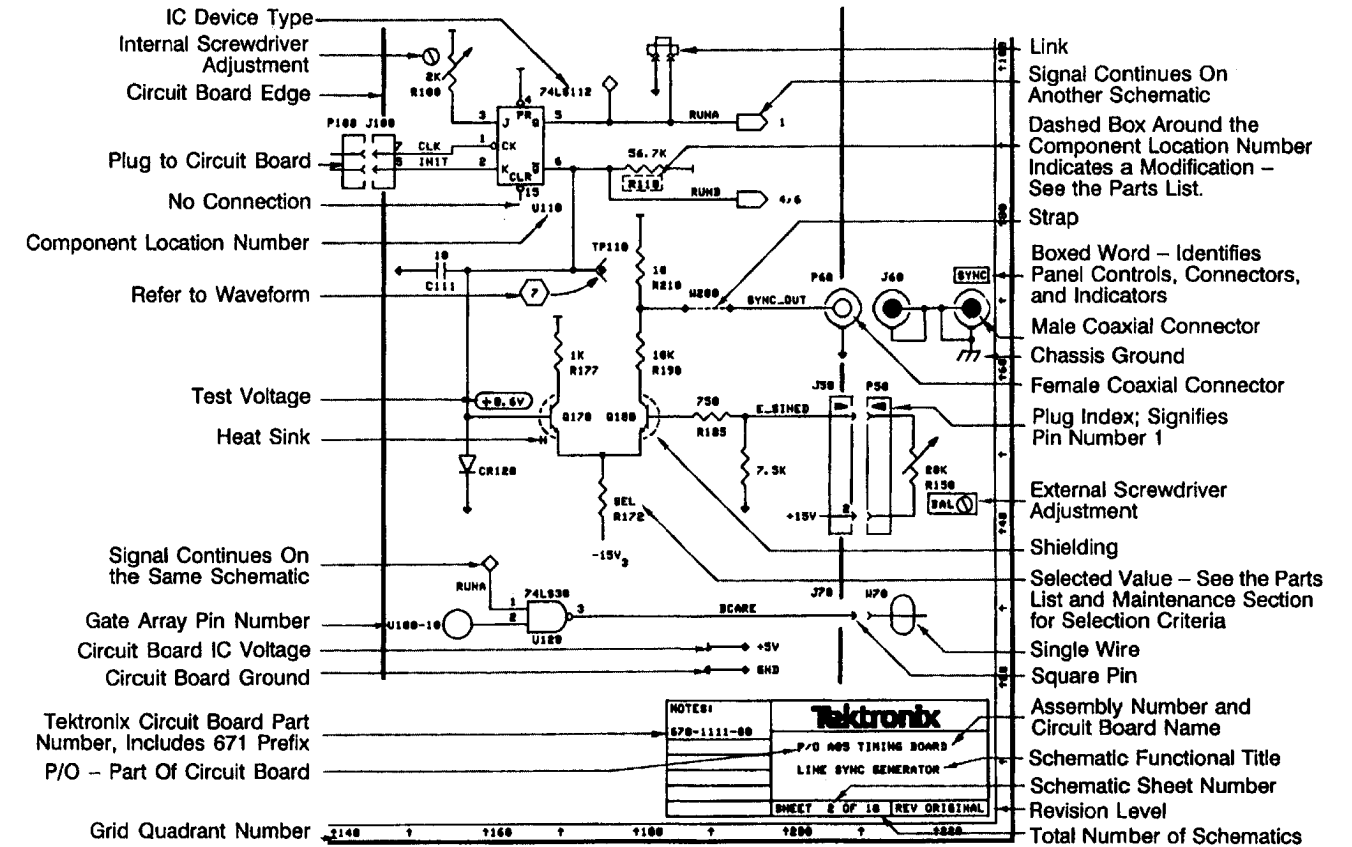

- Link
- Signal Continues On Another Schematic
- Dashed Box Around the Component Location Number Indicates a Modification - See the Parts List.
- Strap
- Boxed Word - Identifies Panel Controls, Connectors, and Indicators
- Male Coaxial Connector
- Chassis Ground
- Female Coaxial Connector
- Plug Index; Signifies Pin Number 1
- External Screwdriver Adjustment
- Shielding
- Selected Value - See the Parts List and Maintenance Section for Selection Criteria
- Single Wire
- Square Pin
- Assembly Number and Circuit Board Name
- Schematic Functional Title
- Schematic Sheet Number
- Revision Level
- Total Number of Schematics

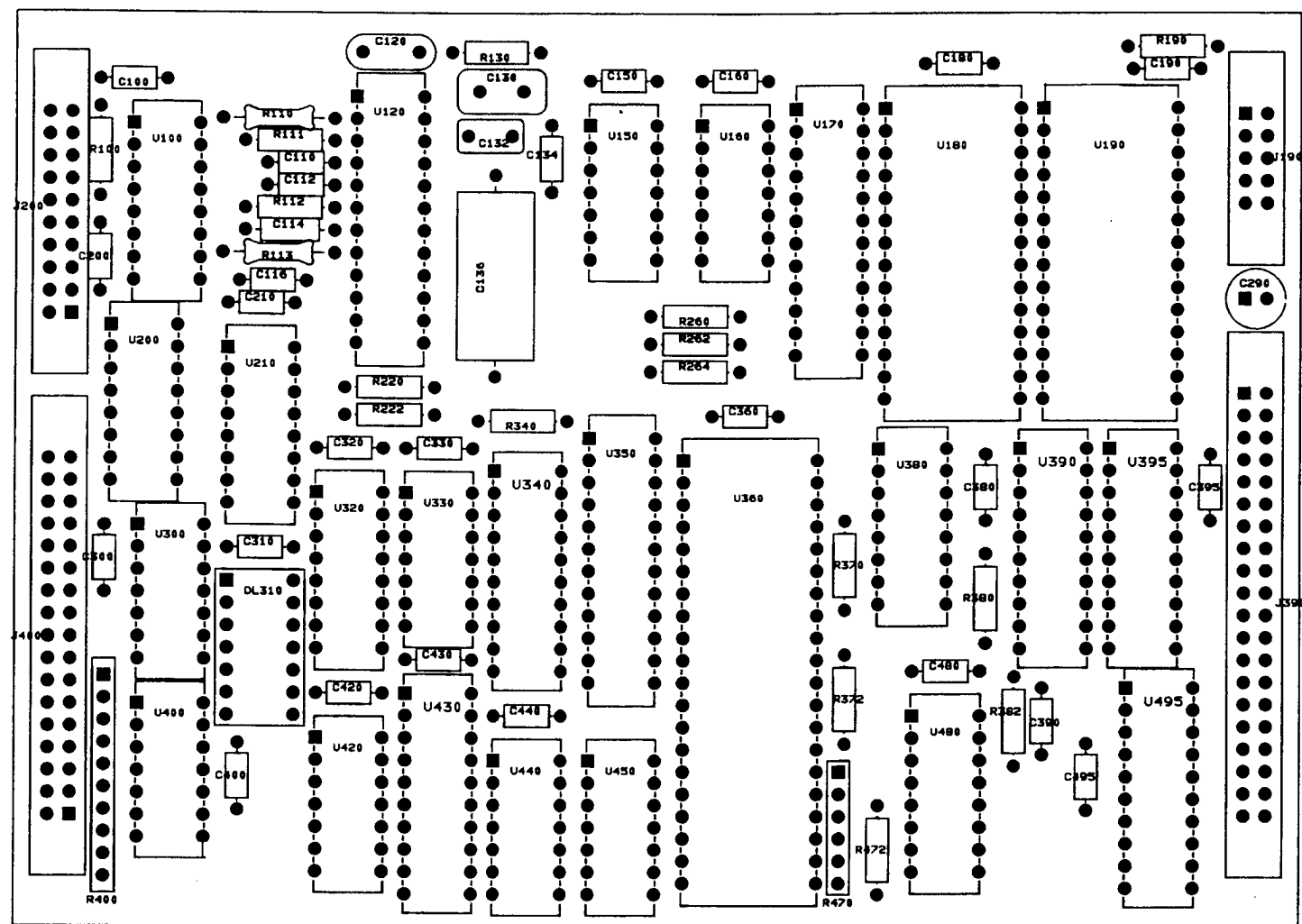

Hard Disk Controller Board Component Locations

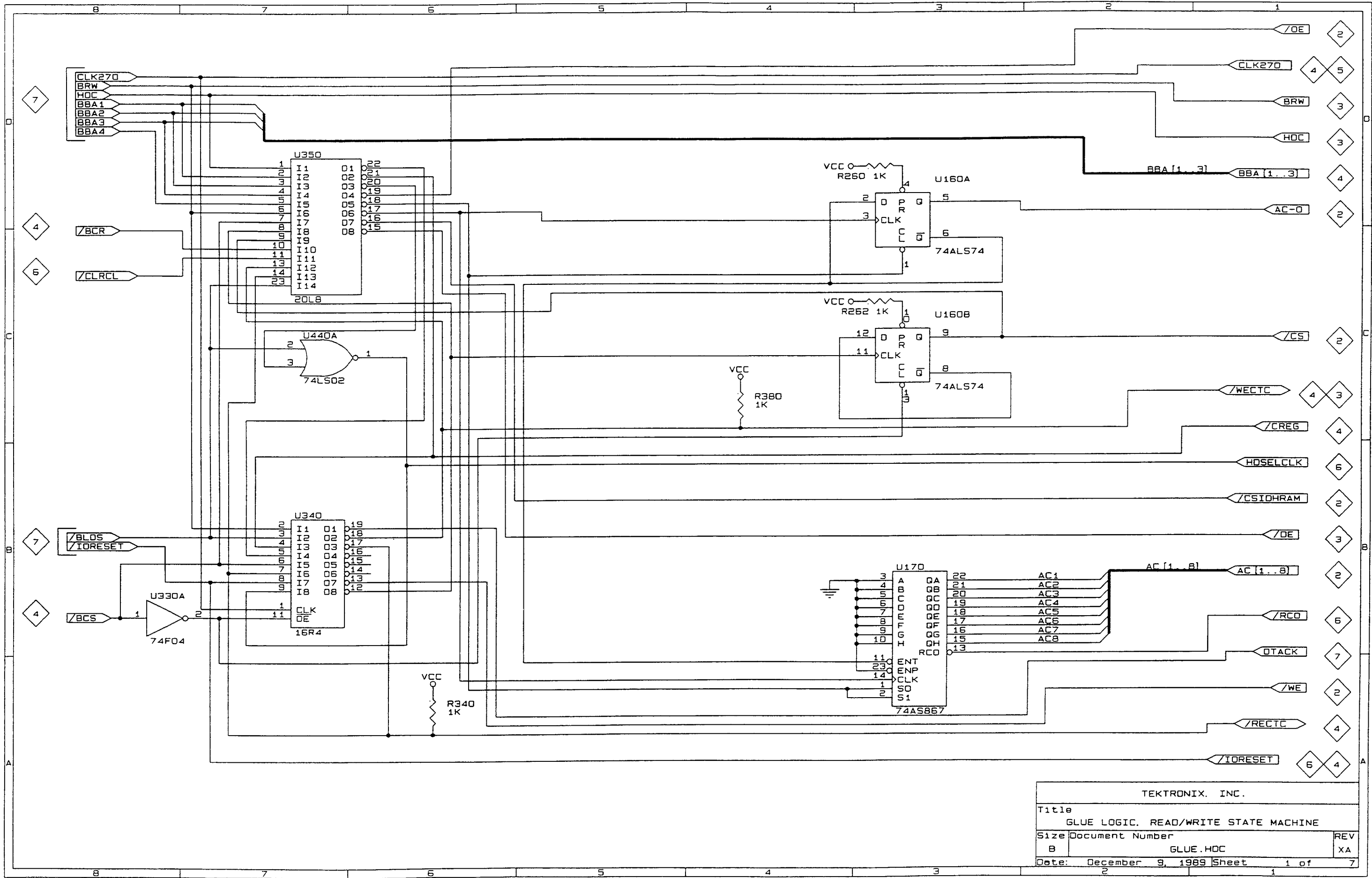

TEKTRONIX, INC.		
Title GLUE LOGIC, READ/WRITE STATE MACHINE		
Size	Document Number	REV
B	GLUE.HDC	XA
Date:	December 9, 1989	Sheet 1 of 7

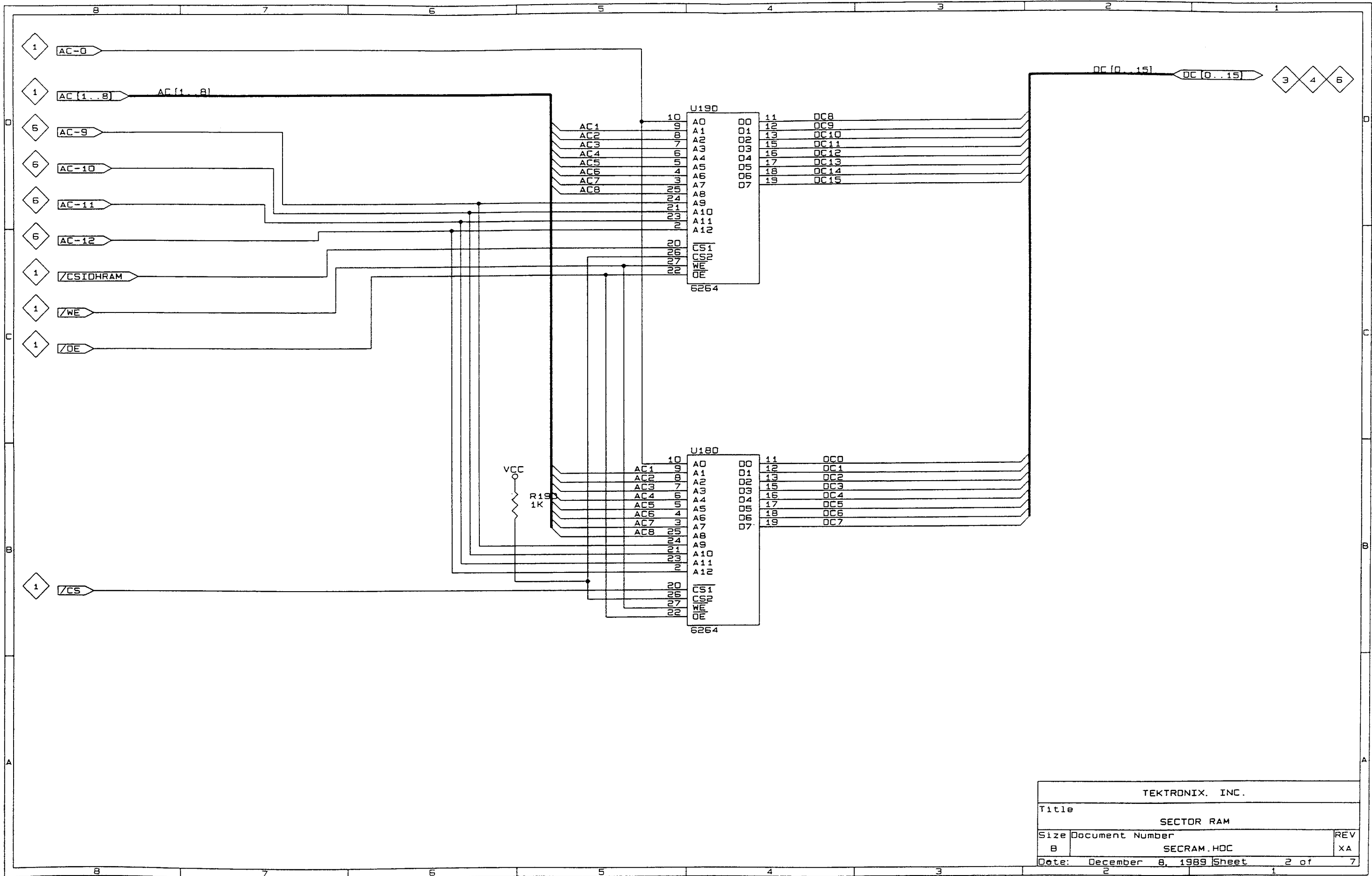

TEKTRONIX, INC.		
Title		
SECTOR RAM		
Size	Document Number	REV
B	SECTOR.HOC	XA
Date:	December 8, 1989	Sheet 2 of 7

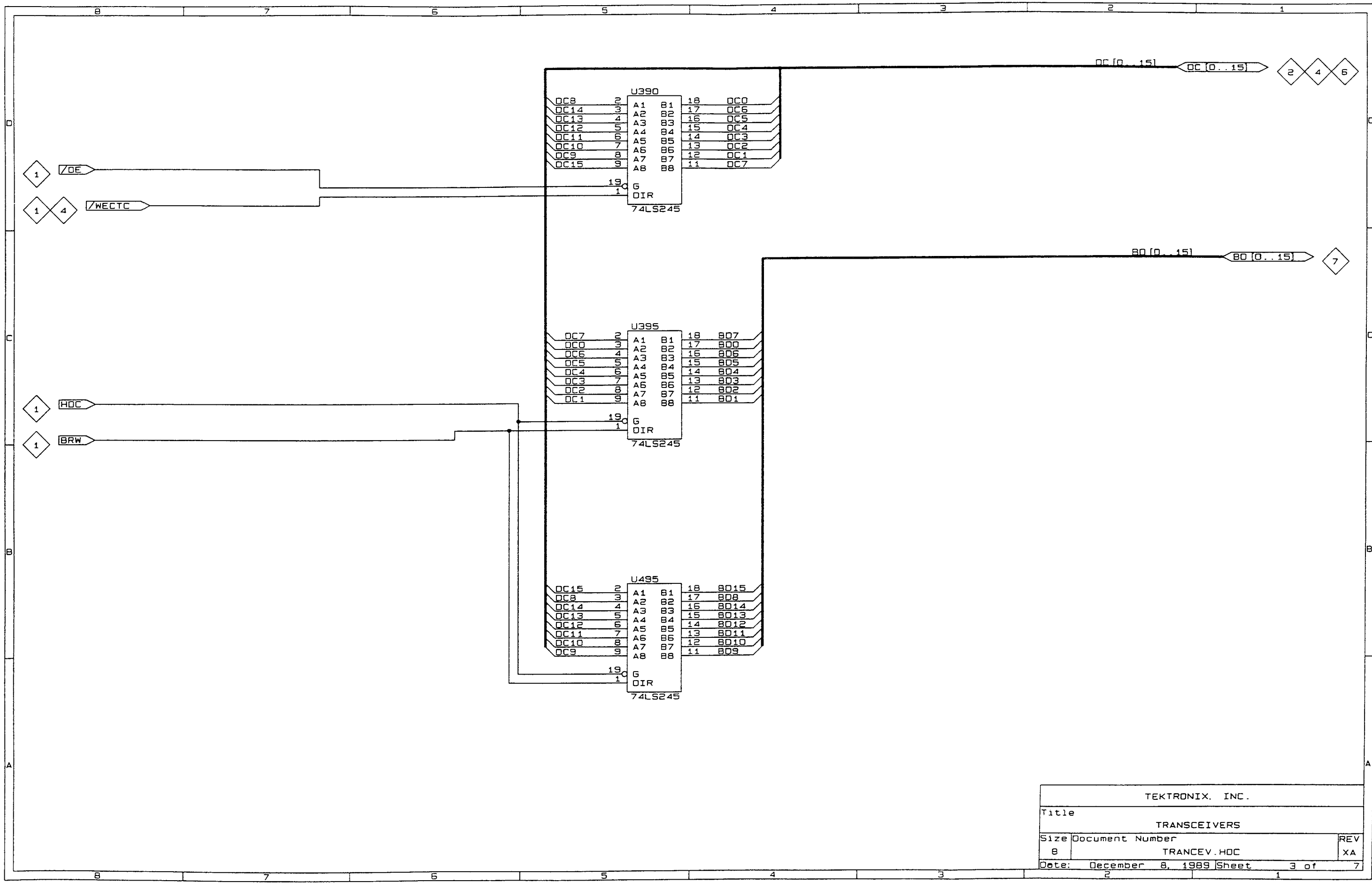

TEKTRONIX, INC.		
Title		
TRANSCIVERS		
Size	Document Number	REV
B	TRANCEV.HDC	XA
Date:	December 8, 1989	Sheet 3 of 7

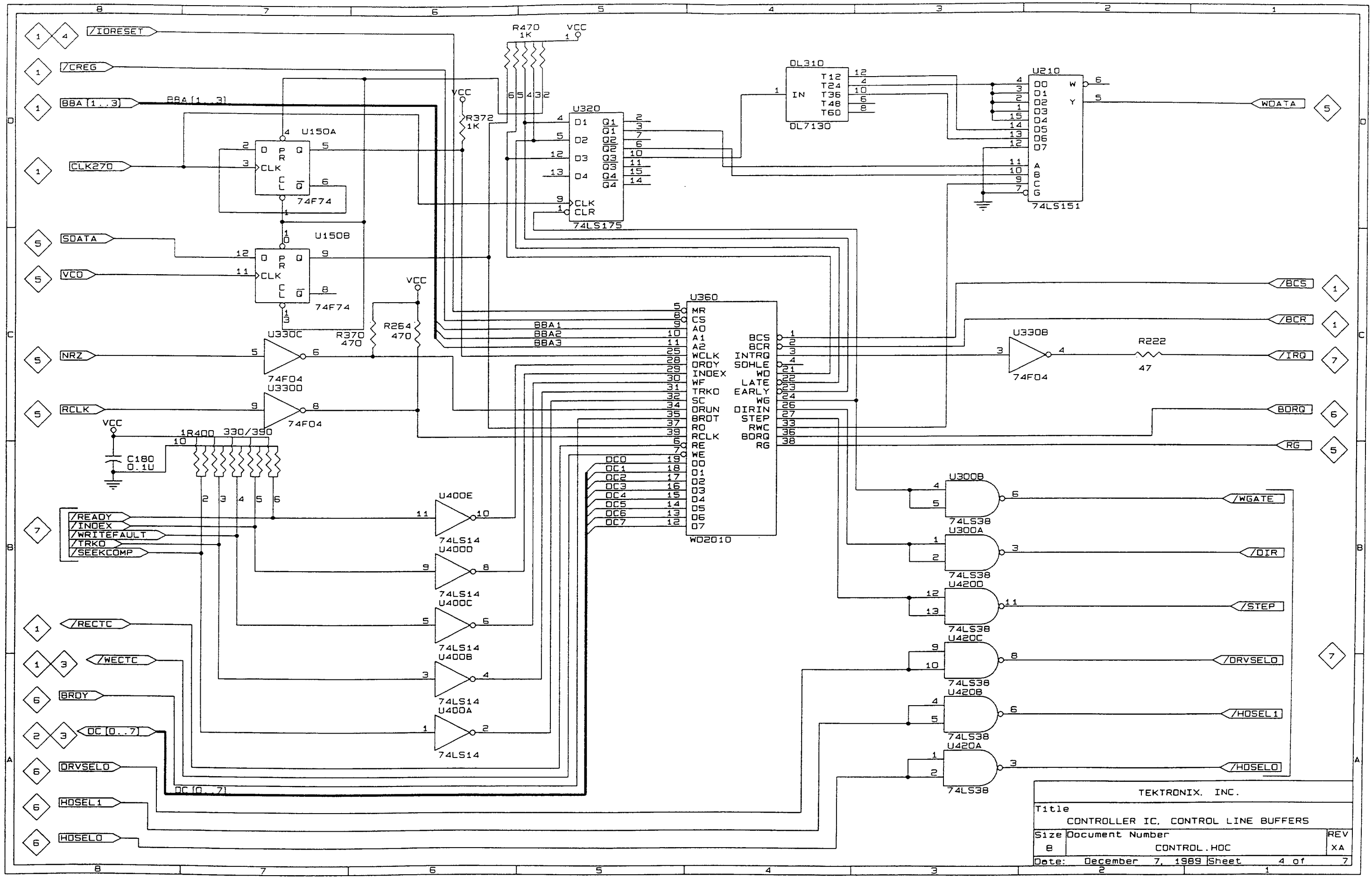

TEKTRONIX, INC.

Title		
CONTROLLER IC, CONTROL LINE BUFFERS		
Size	Document Number	REV
B	CONTROL.HOC	XA
Date: December 7, 1989		Sheet 4 of 7

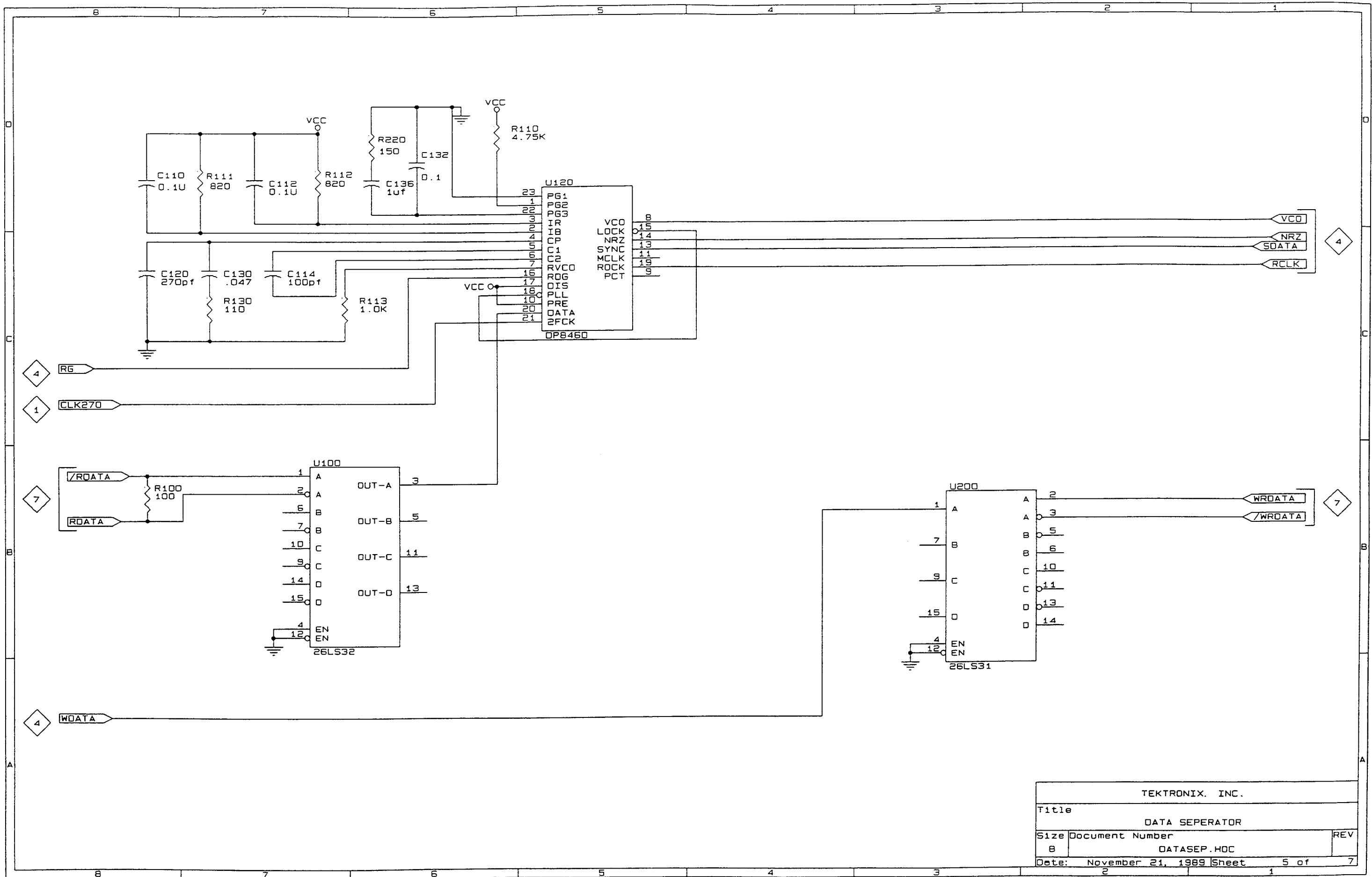

TEKTRONIX, INC.		
Title		
DATA SEPERATOR		
Size	Document Number	REV
8	DATASEP.HOC	
Date: November 21, 1989 Sheet		5 of 7

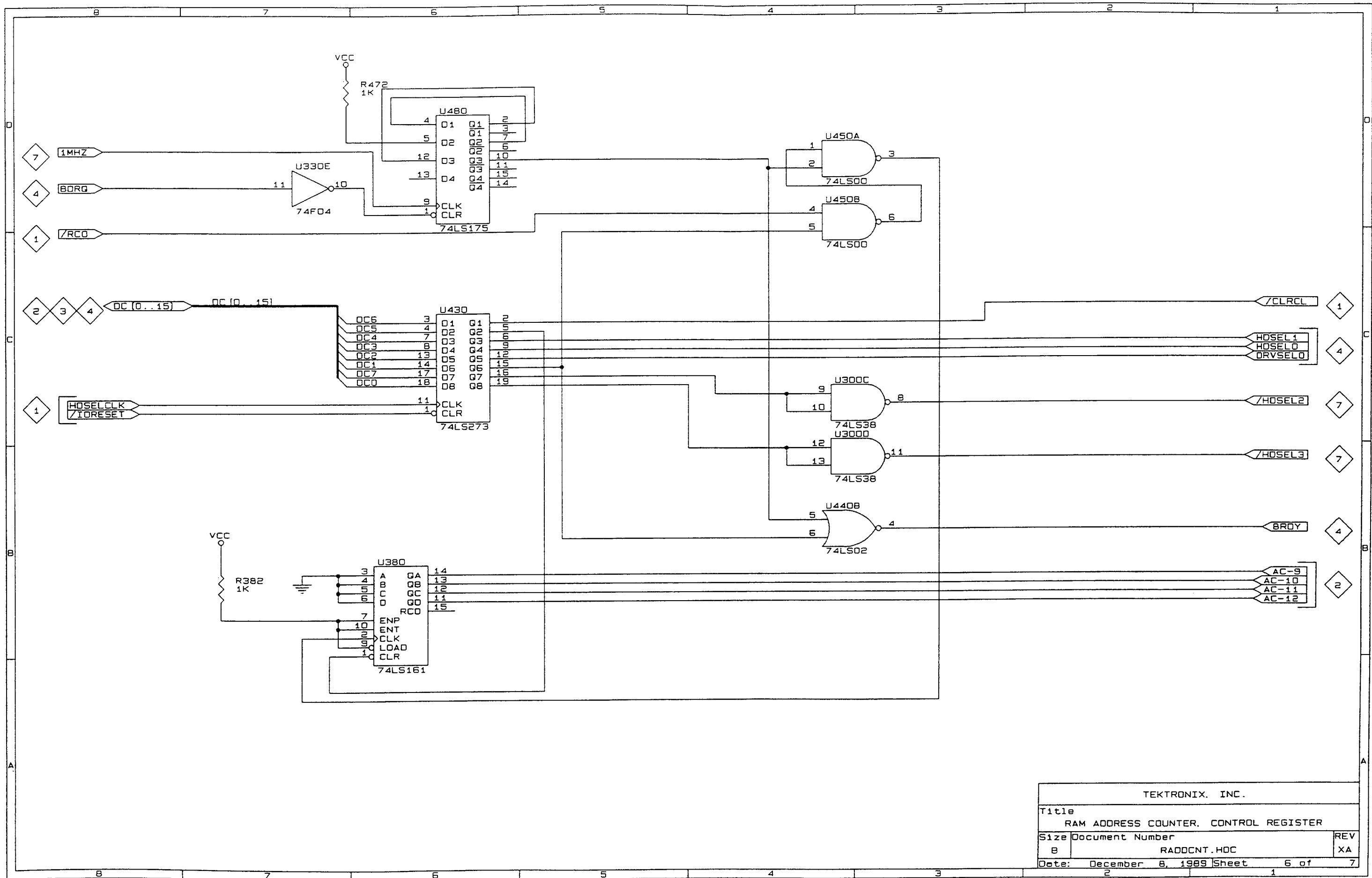

TEKTRONIX, INC.		
Title RAM ADDRESS COUNTER. CONTROL REGISTER		
Size	Document Number	REV
B	RADCNT.HOC	XA
Date:	December 8, 1989	Sheet 6 of 7

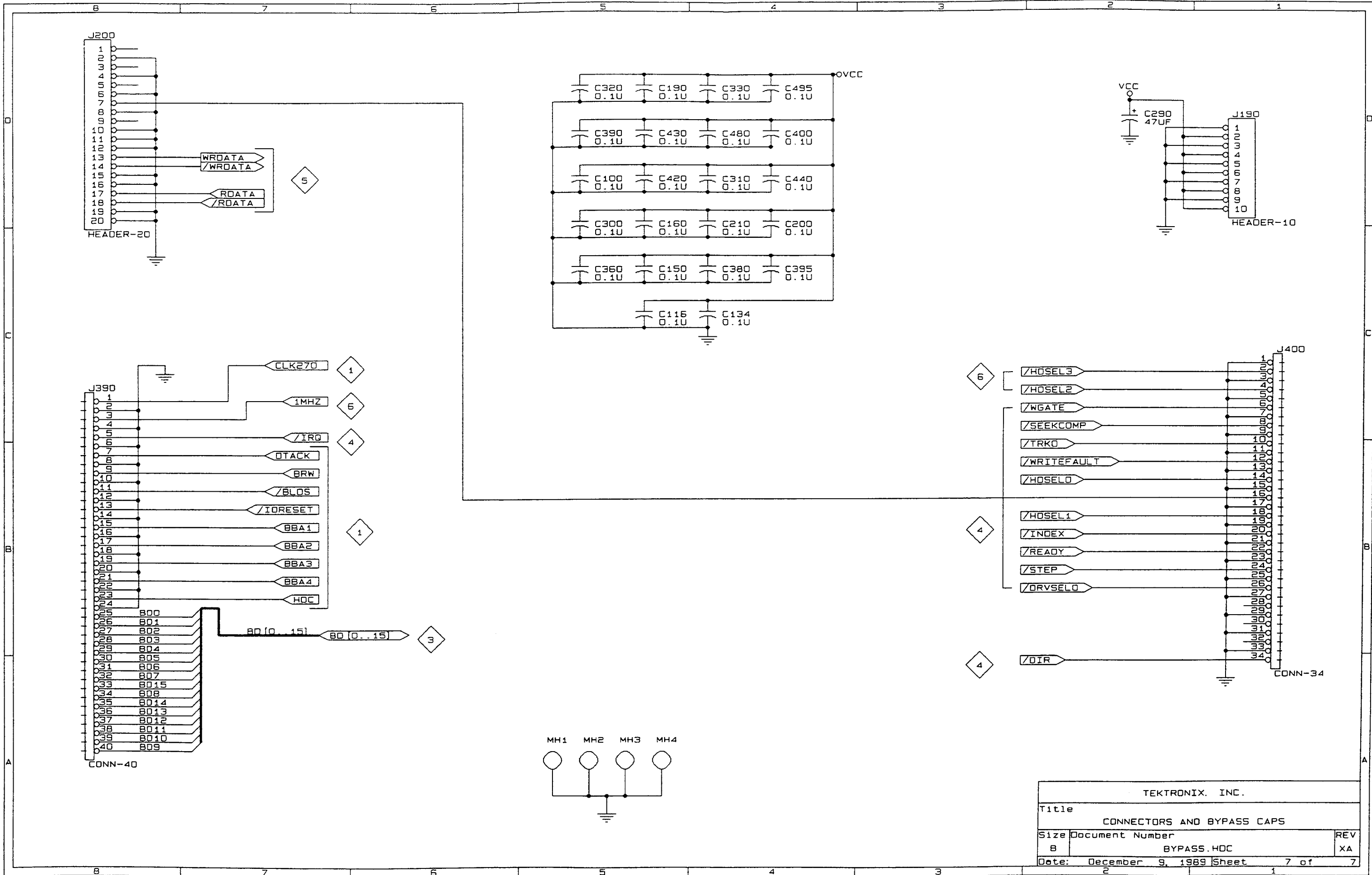

TEKTRONIX, INC.		
Title		
CONNECTORS AND BYPASS CAPS		
Size	Document Number	REV
B	BYPASS.HDC	XA
Date:	December 9, 1989 Sheet	7 of 7
	2	1

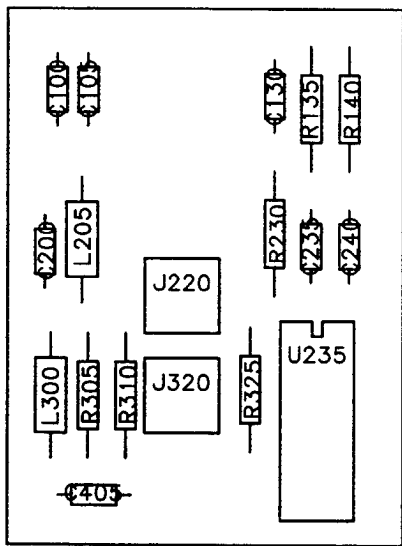

Keyboard Filter Board Component Locations

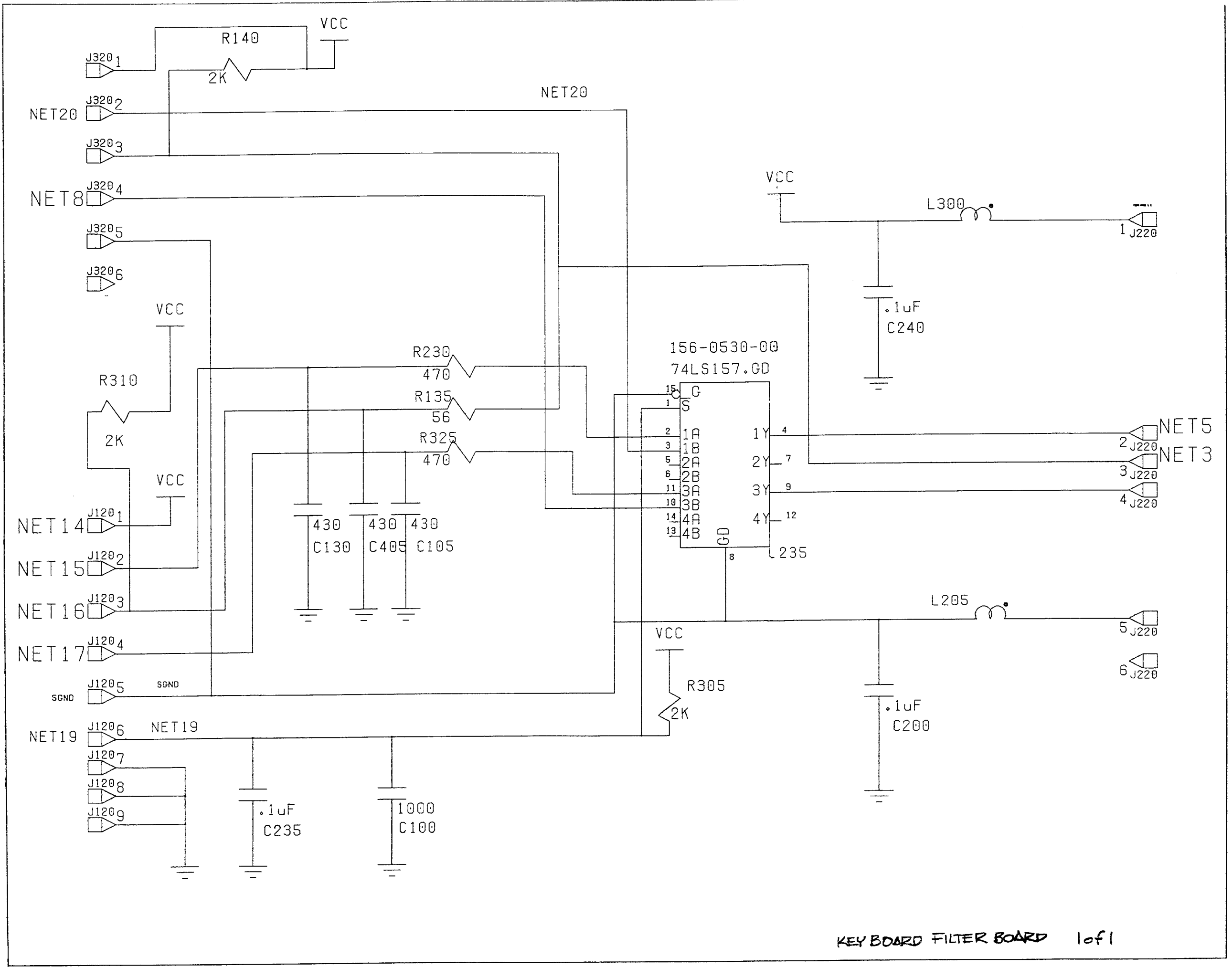

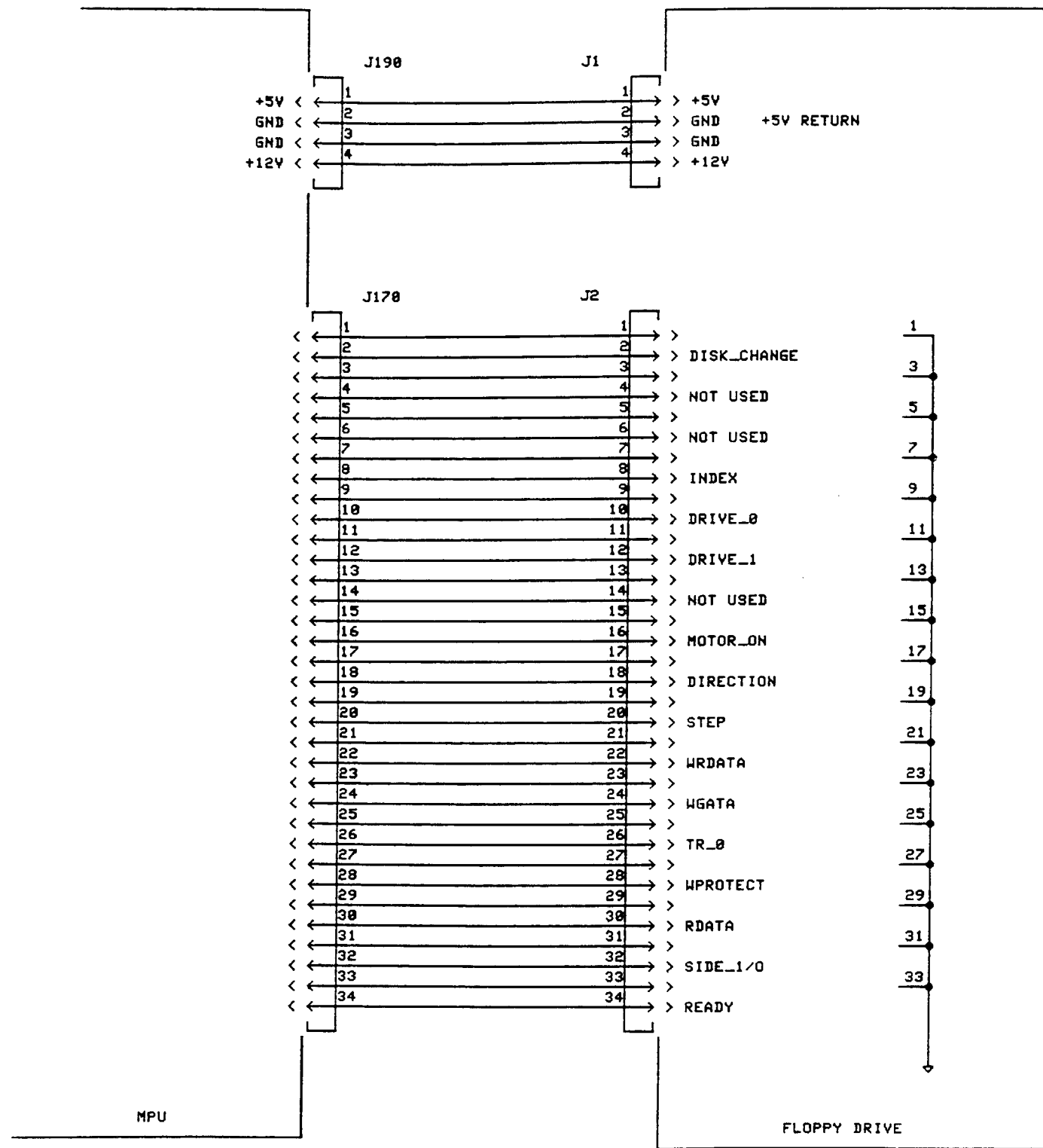

Floppy Drive Signal Interconnect

PRISM 3001GPX Serial Numbers B050130 and Below
 PRISM 3001HSM Serial Numbers B060111 and Below
 PRISM 3001MPX Serial Numbers B030240 and Below
 2505 TestLab Serial Numbers B020127 and Below

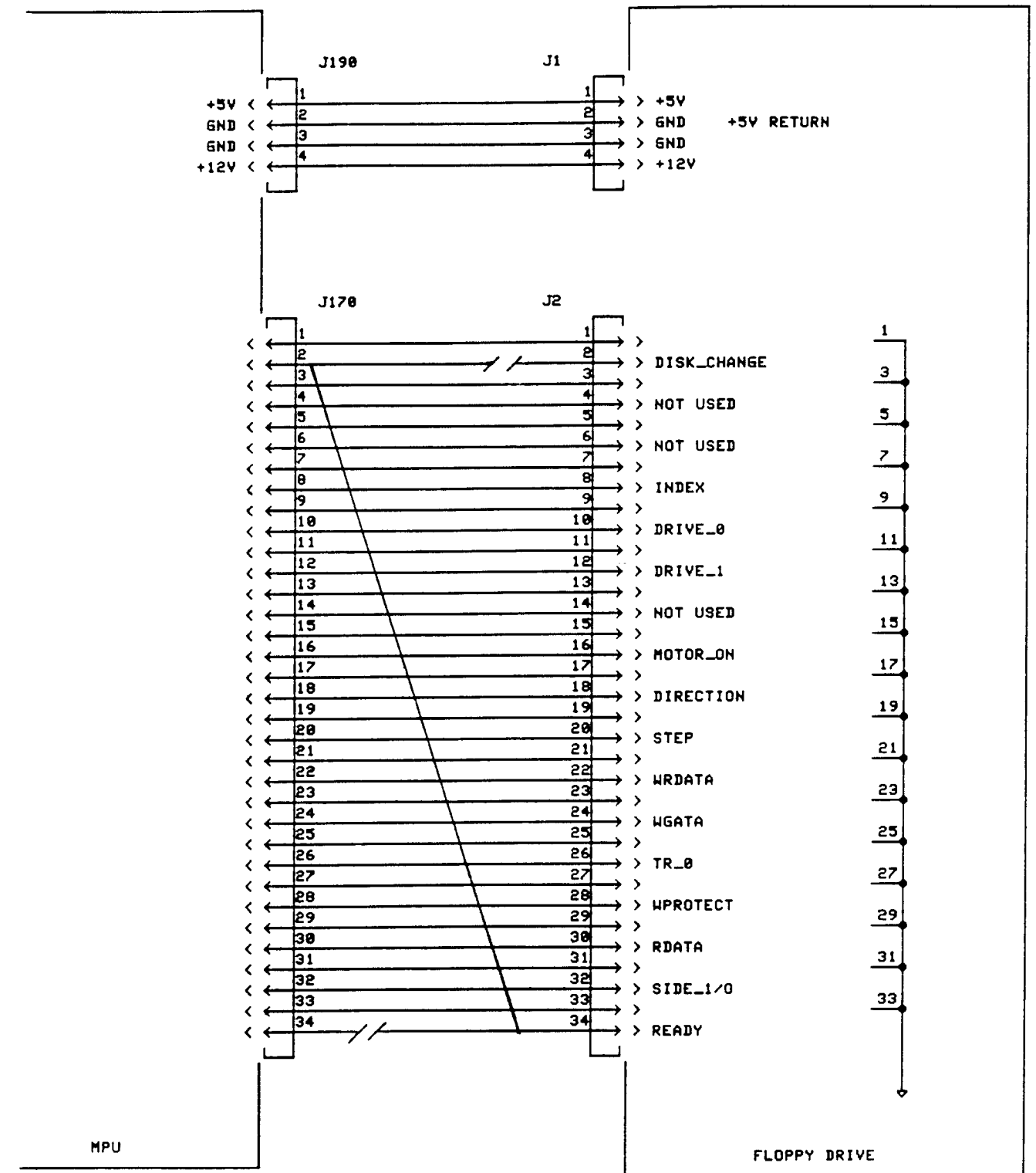

Floppy Drive Signal Interconnect

PRISM 3001GPX Serial Numbers B050131 and Above
 PRISM 3001HSM Serial Numbers B060112 and Above
 PRISM 3001MPX Serial Numbers B030241 and Above
 2505 TestLab Serial Numbers B020128 and Above

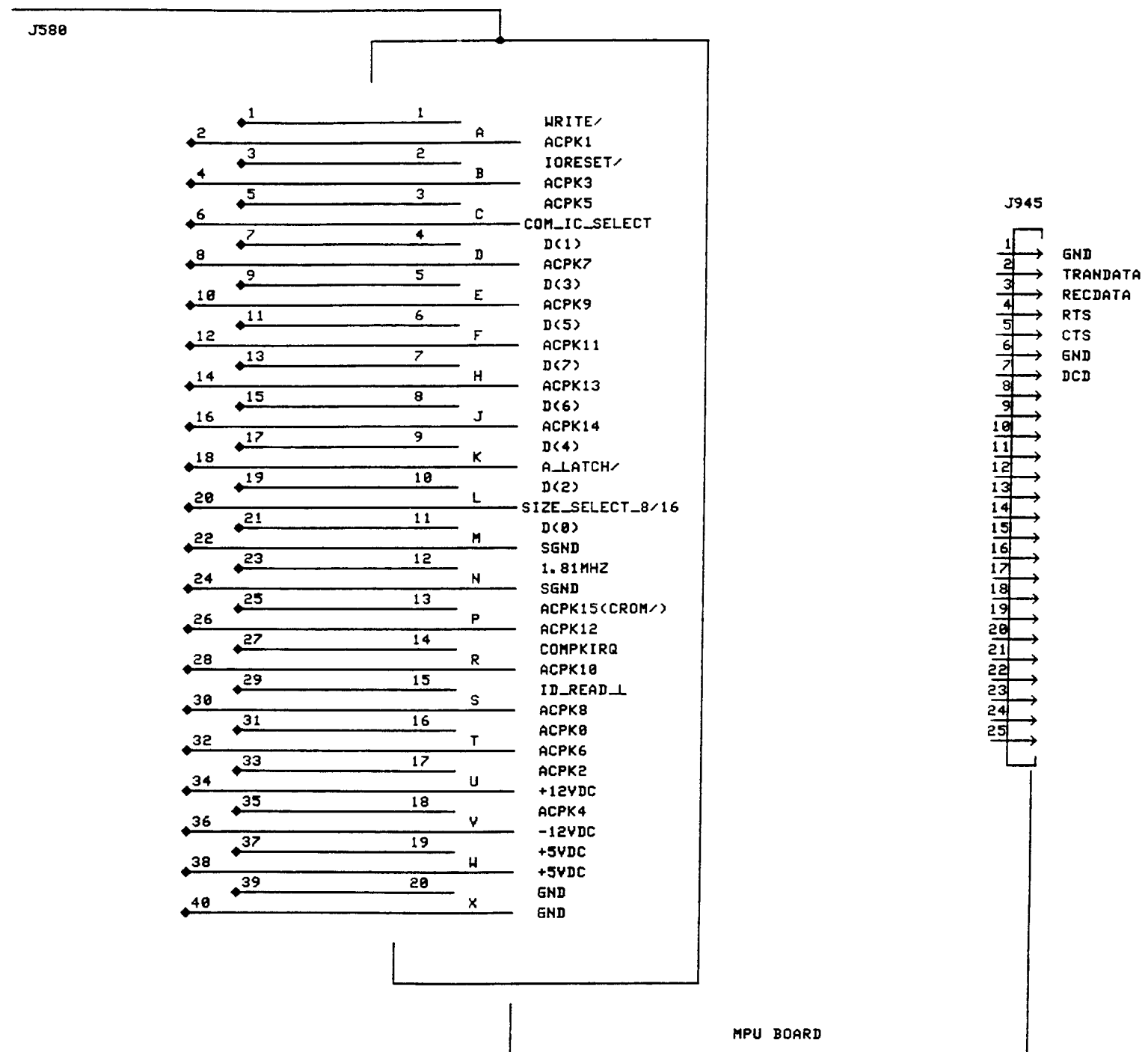

COMM Pack and RS-232 Signal Interconnect

COMM Pack and RS-232 Signal Interconnect

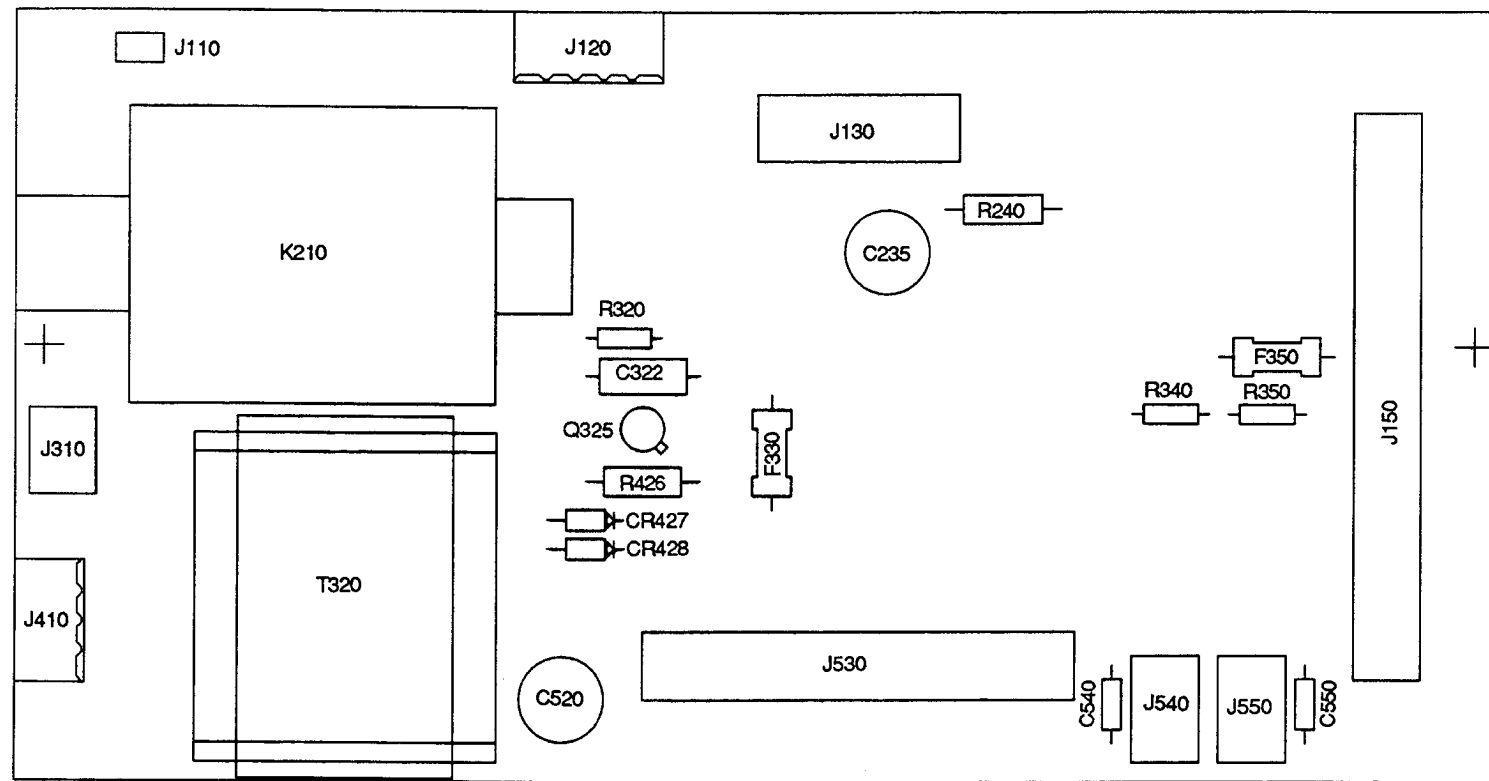

Power Distribution Board Component Locations

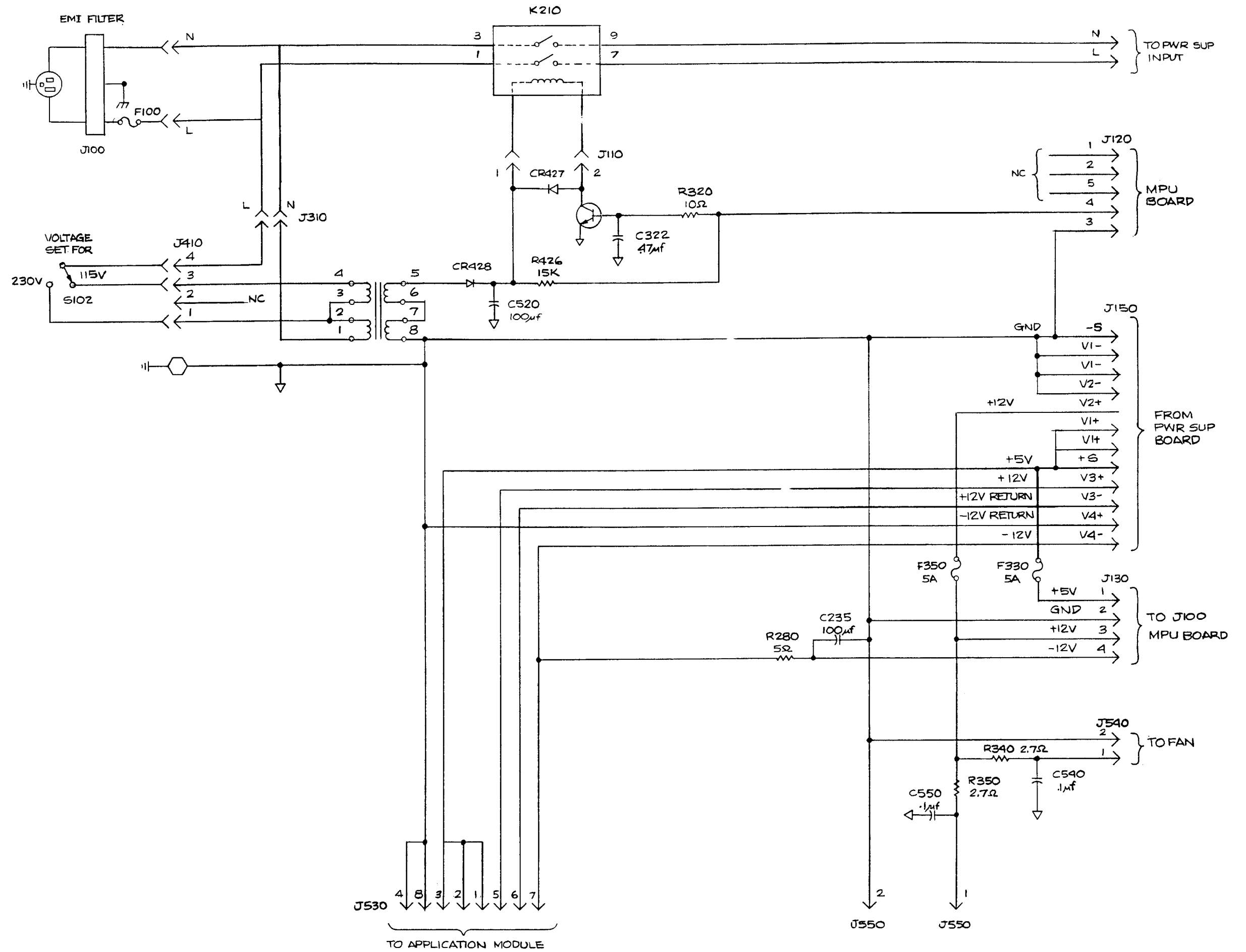

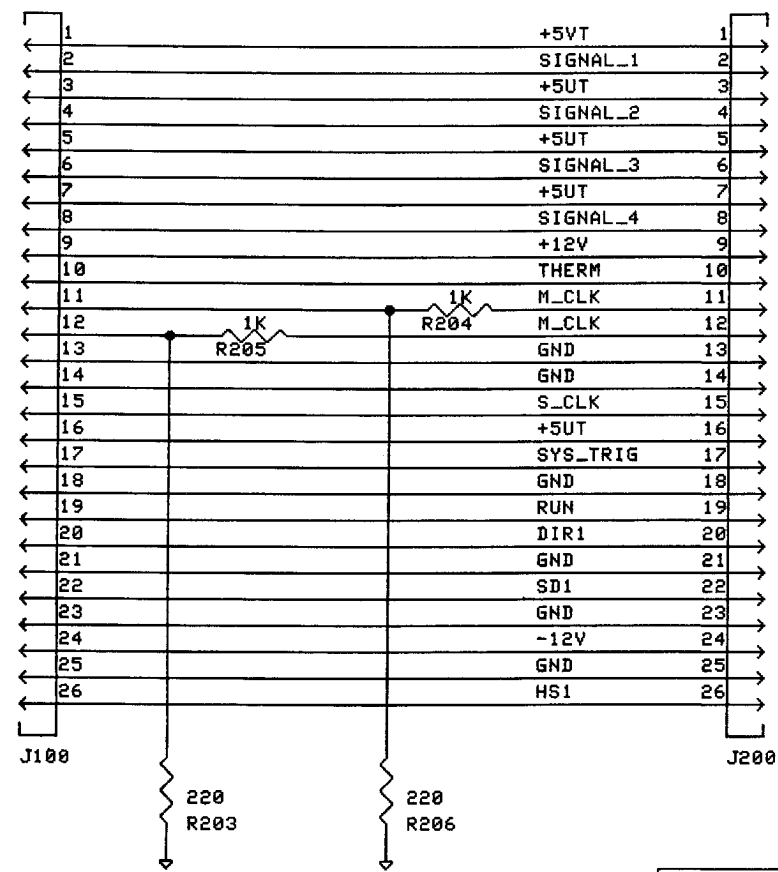

TEKLINK INTERCONNECT

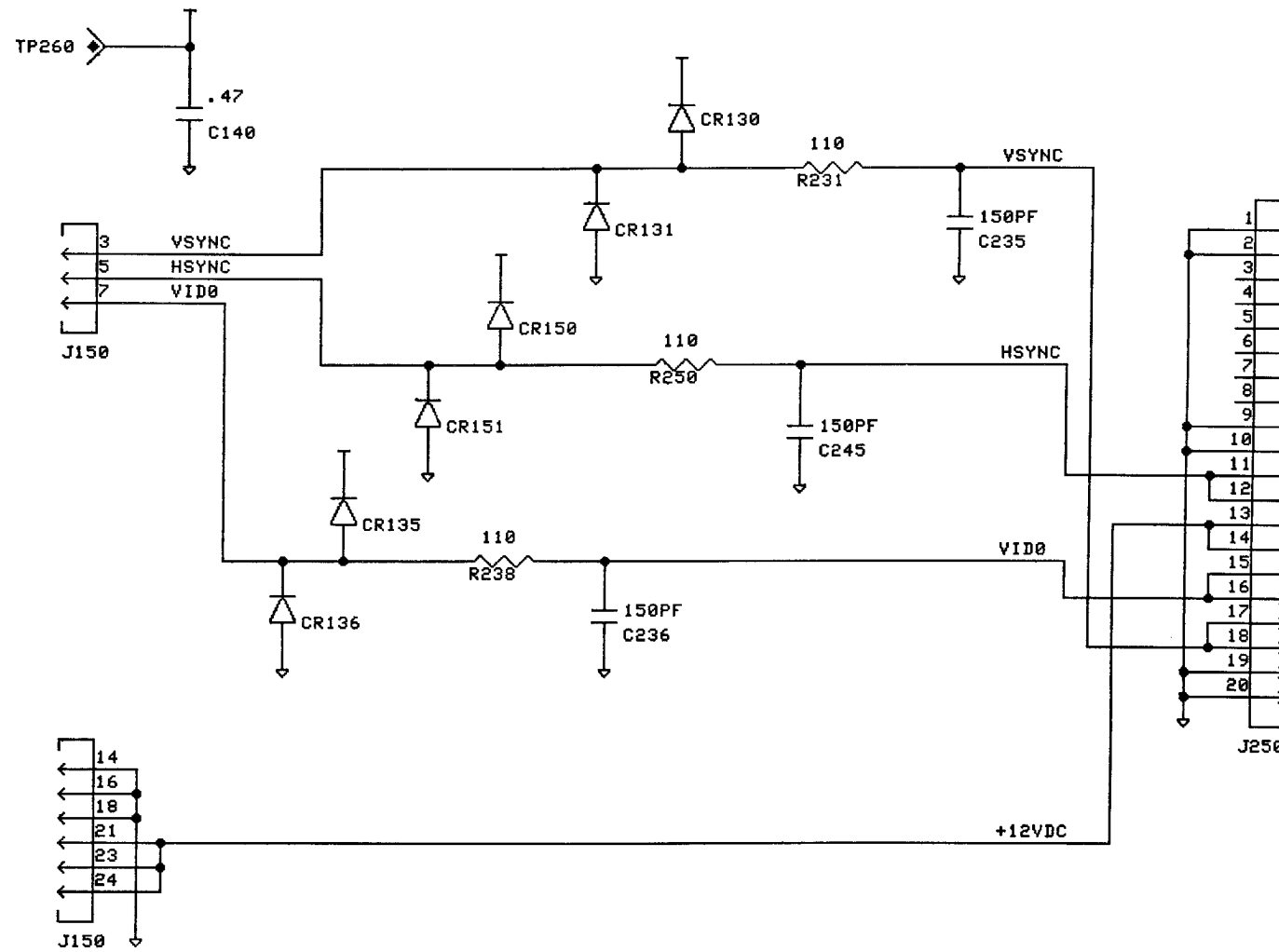

VIDEO INTERCONNECT

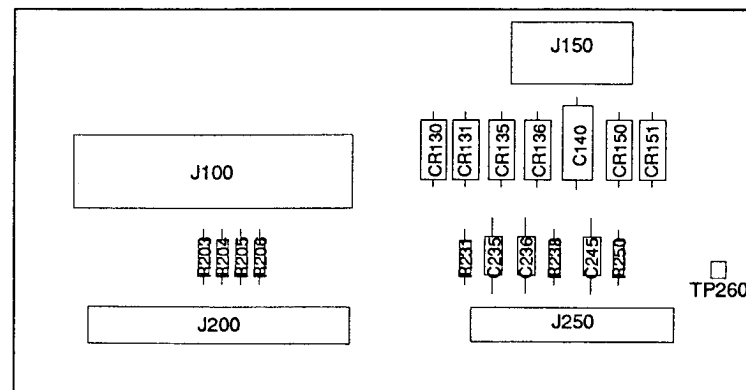

ADD DEC 1992

NOTES:	Tektronix
	671-1371-00
	CONNECTOR ADAPTER BOARD
	SHEET 1 OF 1 REV

— VCC

← GND

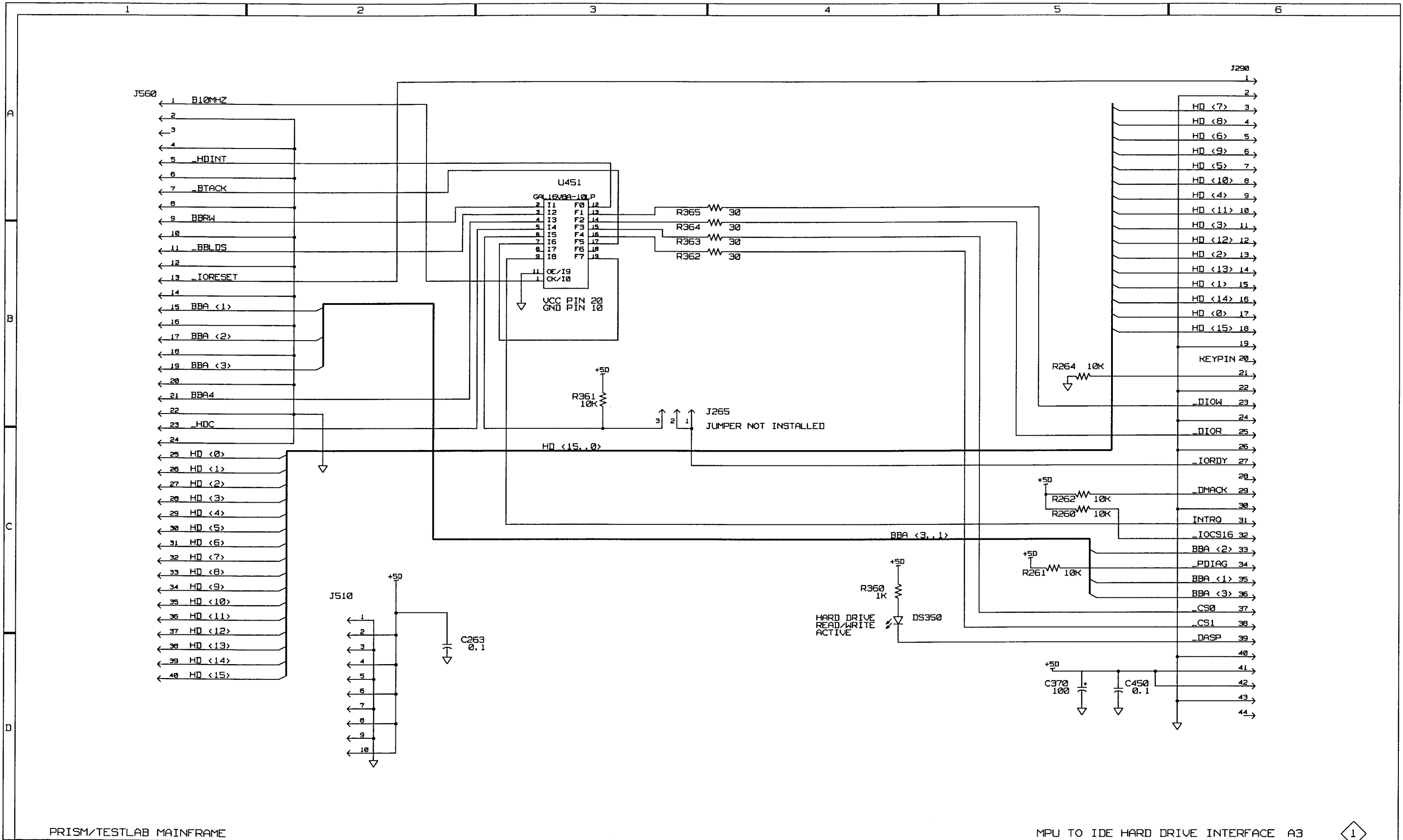

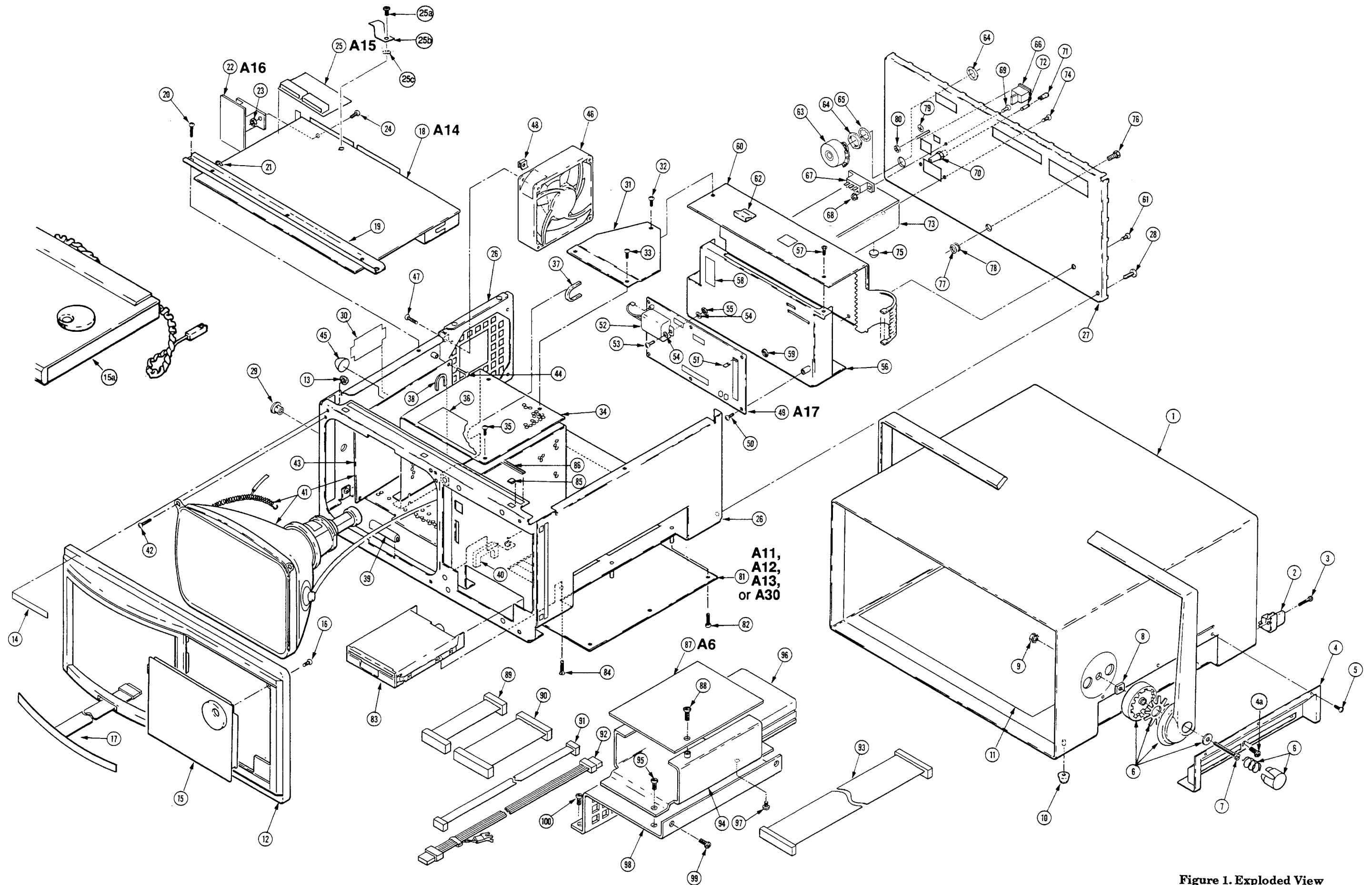
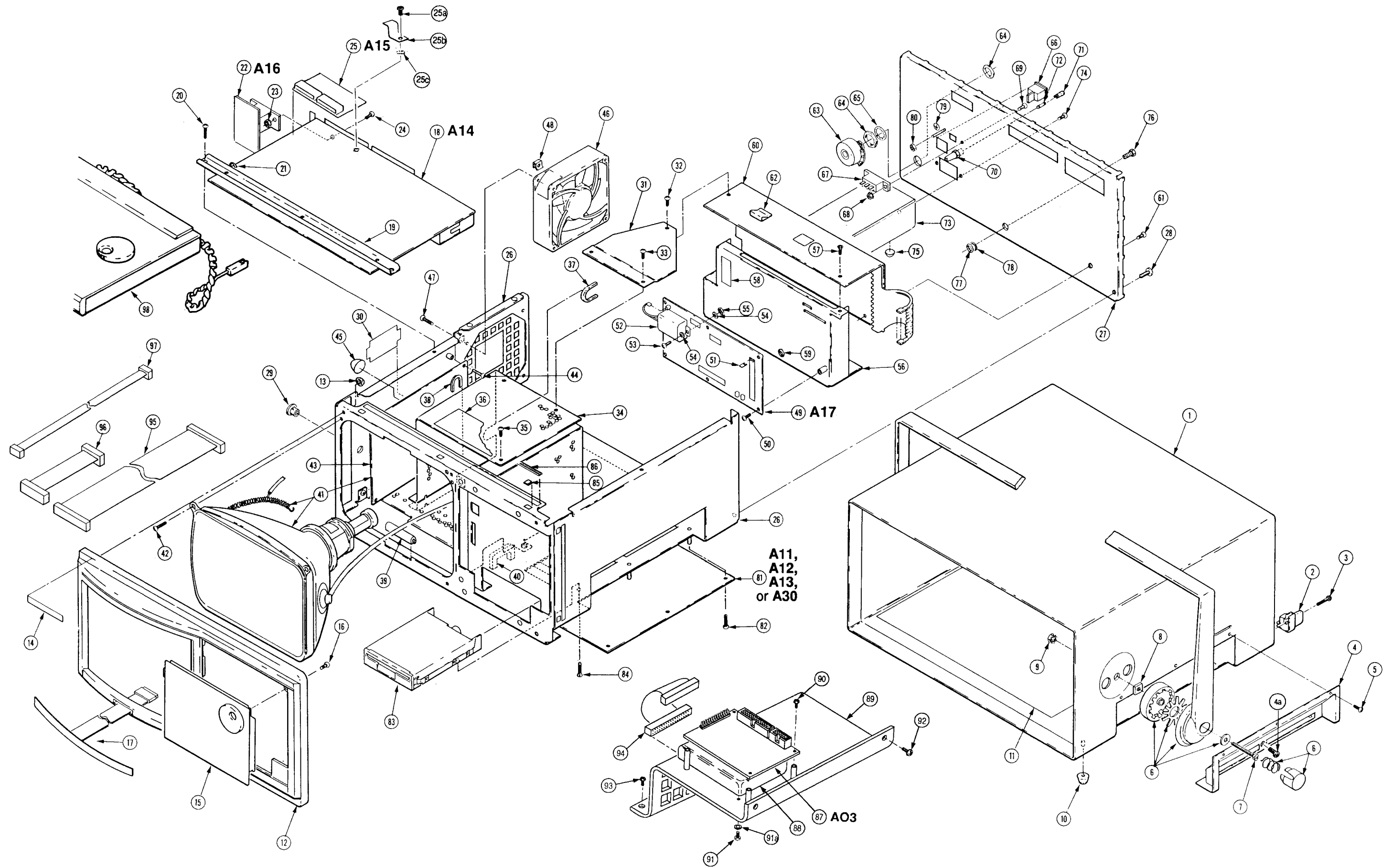

Figure 1. Exploded View

SEE PARTS LIST FOR S/N BREAK



ADD DEC 1992

SEE PARTS LIST FOR S/N BREAK

Figure 2. Exploded View

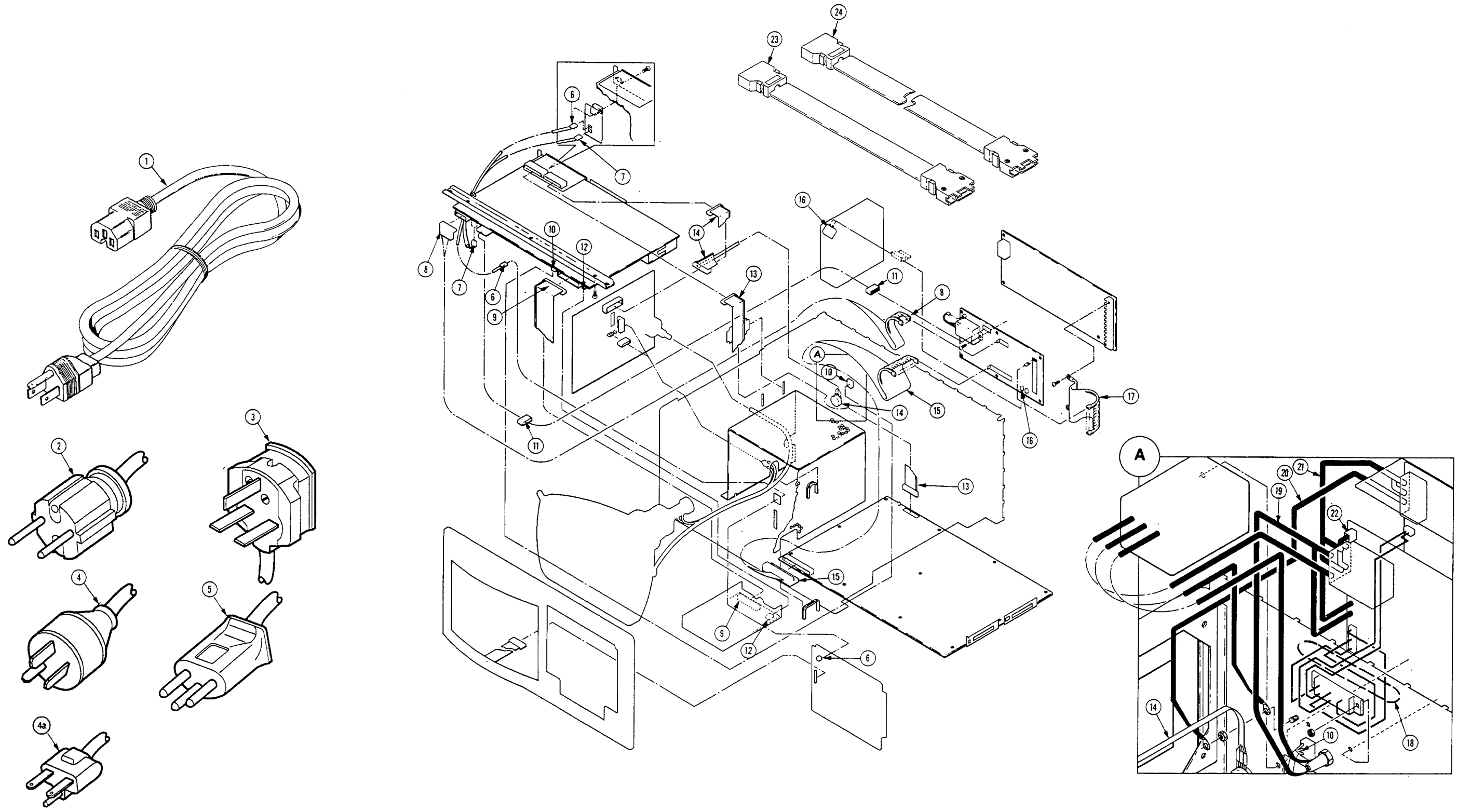

Figure 3. Accessories & Wiring Diagram

Section 11: REPLACEABLE MECHANICAL PARTS

Parts Ordering Information

Replacement parts are available from or through your local Tektronix, Inc. service center or representative.

When ordering parts, it is important to include the following information in your order:

- Part number
- Instrument type or model number
- Instrument serial number
- Instrument modification number, if applicable

If a part you order has been replaced with a different or improved part, your local Tektronix service center or representative will contact you concerning any change in the part number.

Change information, if any, is located at the rear of this manual.

Module Servicing

Your module can be serviced by selecting one of the following three options:

- **Module Exchange.** In some cases you may exchange your module for a remanufactured module. These modules cost significantly less than new modules and meet the same factory specifications. For more information about the module exchange program, call 1-800-835-9433.
- **Module Repair and Return.** You may ship your module to us for repair, after which we will return it to you.
- **New Modules.** You may purchase new replacement modules in the same way as other replacement parts.

Using the Replaceable Parts List

The tabular information in the Replaceable Parts List is arranged for quick retrieval. Understanding the structure and features of the list will help you find all the information you need for ordering replacement parts.

Component Number (column 1)

Identifies the figure and index number used on the mechanical exploded view.

Tektronix Part Number (column 2)

Indicates part number to be used when ordering replacement part from Tektronix.

Replaceable Electrical Parts

The circuit component number appears on the diagrams and circuit board illustrations. Each diagram and circuit board illustration is clearly marked with the assembly number. Assembly numbers are also marked on the mechanical exploded views located in the mechanical parts list. The component number is obtained by adding the assembly number prefix to the circuit number.

The Electrical Parts List is divided and arranged by assemblies in numerical sequence (e.g., assembly A1 with its subassemblies and parts, precedes assembly A2 with its subassemblies and parts).

Chassis-mounted parts have no assembly number prefix and are located at the end of the Electrical Parts List.

Tektronix Part Number (column 2)	Indicates part number to be used when ordering replacement part from Tektronix.
Serial Number (columns 3 & 4)	Column three (3) indicates the serial number at which the part was first used. Column four (4) indicates the serial number at which the part was removed. No serial number indicates part is good for all serial numbers.
Name and Description (column 5)	In the Parts List, an Item Name is separated from the description by a colon(:). Because of space limitations, an Item Name may sometimes appear as incomplete. For further Item Name identification, the U.S. Federal Cataloging Handbook H6-1 can be utilized where possible.
Mfr. Code (column 6)	Indicates the code number of the actual manufacturer of the part. (Code to name and address cross reference can be found immediately after this page.)
Mfr. Part Number (column 7)	Indicates actual manufacturer's part number.

CROSS INDEX – MFR CODE NUMBER TO MANUFACTURER

Mfr Code	Manufacturer	Address	City, State, Zip Code
00779	AMP INC	2800 FULLING MILL	HARRISBURG PA 17105
01536	TEXTRON INC CAMCAR DIV	1818 CHRISTINA ST	ROCKFORD IL 61108
06383	PANDUIT CORP	17301 RIDGELAND	TINLEY PARK IL 07094-2917
06915	RICHCO PLASTIC CO	5825 N TRIPP AVE	CHICAGO IL 60646-6013
07416	NELSON NAME PLATE CO	3191 CASITAS	LOS ANGELES CA 90039-2410
08445	ELECTRI-CORD MFG CO INC	312 EAST MAIN ST	WESTFIELD PA 16990
03260	COMTEK MANUFACTURING OF OREGON	PO BOX 4200	BEAVERTON OR 97076-4200
039P9	GEROME MFG CO INC	PO BOX 737	NEWBURG OR 97132
03R05	TRIQUEST CORP	3000 LEWIS AND CLARK HWY	VANCOUVER WA 98661-2999
0KB01	STAUFFER SUPPLY	810 SE SHERMAN	PORTLAND OR 97214
12300	POTTER AND BRUMFIELD DIV	AMF CANADA LTD 52 ROYAL RD PO BOX 3620	GURLPH ONT CAN N1H 7H1
12327	FREEWAY CORP	9301 ALLEN DR	CLEVELAND OH 44125-4632
17954	BALL CORP	1950 33RD ST	BOULDER CO 80302
1Y013	ACACIA/DEANCO	3101 SW 153RD DRIVE	BEAVERTON OR 97006
22670	G M NAMEPLATE INC	2040 15TH AVE WEST	SEATTLE WA 98119-2728
28520	HEYCO MOLDED PRODUCTS	750 BOULEVARD	KENILWORTH NJ 07033-1721
29870	VICTOR CORP	618 MAIN STREET WEST	WARWICK RI 02893
2K262	BOYD CORP	6136 NE 87th AVE	PORTLAND OR 97220
2W944	PAPST MECHATRONIC CORP	AQUIDNECK INDUSTRIAL PK	NEWPORT R 02840
30817	INSTRUMENT SPECIALTIES CO INC	EXIT 53 RT 80	DELAWARE WATER GAP PA 18327
50356	TEAC AMERICA INC	7733 TELEGRAPH ROAD	MONTEBELLO CA 90640-6537
52152	MINNESOTA MINING AND MFG CO	3M CENTER	ST PAUL MN 55144-0001
54972	CLINTON ELECTRONICS CORP	6701 CLINTON RD	ROCKFORD IL 61111-3863
59666	ADVANCED INPUT DEVICES	WEST 250 A I D DR	COEUR D ALENE ID 83814
5Y400	TRIAx METAL PRODUCTS INC	1800 216TH AVE NW	HILLSBORO OR 97124-6629
62559	SCHROFF INC	170 COMMERCE DR	WARWICK RI 02886-2430
65867	SEAGATE	920 DISC DR	SCOTT'S VALLEY CA 95066-4544
70485	ATLANTIC INDIA RUBBER WORKS INC	571 W POLK ST	CHICAGO IL 60607
71400	BUSSMANN DIV OF COOPER INDUSTRIES INC	114 OLD STATE RD PO BOX 14460	ST LOUIS MO 63178
73743	FISCHER SPECIAL MFG CO	111 INDUSTRIAL RD	COLD SPRING KY 41076-9749
74970	JOHNSON E F CO	299 10TH AVE S W	WASECA MN 56093-2539
75915	LITTELFUSE INC	800 E NORTHWEST HWY	DES PLAINES IL 60016-3049
78189	ILLINOIS TOOL WORKS INC	ST CHARLES ROAD	ELGIN IL 60120
7W718	MARQUARDT SWITCHES INC	2711 ROUTH 20 EAST	CAZENOVIA NY 13035-1219
80009	TEKTRONIX INC	14150 SW KARL BRAUN DR	BEAVERTON OR 97077-0001
83486	ELCO INDUSTRIES INC	1101 SAMUELSON RD	ROCKFORD IL 61101
85471	BOYD CORP	13885 RAMONA AVE	CHINO CA 91710
93907	TEXTRON INC	600 18TH AVE	ROCKFORD IL 61108-5181
S3109	FELLER	72 Veronica Ave	Summerset NJ 08873
S3629	SCHURTER AG H	2015 SECOND STREET	BERKELEY CA 94170

Replaceable Mechanical Parts

CROSS INDEX – MFR CODE NUMBER TO MANUFACTURER

Mfr Code	Manufacturer	Address	City, State, Zip Code
TK0196	ALMAC-STROUM ELECTRONICS (DIST)	1885 NW 169TH PLACE	BEAVERTON OR 97006
TK0435	LEWIS SCREW CO	4300 S RACINE AVE	CHICAGO IL 60609-3320
TK1123	ALL METRIC CO	3201 UTAH AVE S	SEATTLE WA 98134-1816
TK1373	PATELEC-CBM (ITALY)	10156 TORINO	VAICENTALLO 62/45S ITALY
TK1423	WACHTEL CO INC THE (DIST)	1100-B L AVENIDA ST	MOUNTAIN VIEW CA 94043
TK1465	BEAVERTON PARTS MFG CO	1800 NW 216TH AVE	HILLSBORO OR 97124-6629
TK1475	SWITCHING SYSTEMS INTERNATIONAL	1827 N CASE	ORANGE CA 92655
TK2437	KALOK CORPORATION	1289 ANVILWOOD AVE	SUNNYVALE CA 94089
TK2469	UNITREK CORPORATION	3000 LEWIS & CLARK WAY	VANCOUVER WA 98601

REPLACEABLE MECHANICAL PARTS

Fig. & Index No.	Tektronix Part Number	Serial Number Effect	Discont	Qty	12345 Part Name & Description	Mfr Code	Mfr Part Number
1 -1	437-0397-00	B010100	B029999	1	CABINET:3001	QJ260	437-0397-00
	437-0440-00	B030100		1	CABINET:3001 (3001MPX ONLY)	QJ9P9	ORDER BY DESCRIPTION
	437-0397-00	B010100	B039999	1	CABINET:3001	QJ260	437-0397-00
	437-0440-00	B040100		1	CABINET:3001 (3001HSM ONLY)	QJ9P9	ORDER BY DESCRIPTION
	437-0397-00	B010100	B010293	1	CABINET:3001	QJ260	437-0397-00
	437-0440-00	B010294		1	CABINET:3001 (2505 ONLY)	QJ9P9	ORDER BY DESCRIPTION
-2	348-1154-00	B010100	B029999	4	FOOT,CABINET:EARTH BROWN,PLASTIC	QJR05	348-1154-00
	348-1297-00	B030100		4	FOOT,CABINET:TEK BLUE,PLASTIC (3001MPX ONLY)	QJR05	ORDER BY DESCRIPTION
	348-1154-00	B010100	B039999	4	FOOT,CABINET:EARTH BROWN,PLASTIC	QJR05	348-1154-00
	348-1297-00	B040100		4	FOOT,CABINET:TEK BLUE,PLASTIC (3001HSM ONLY)	QJR05	ORDER BY DESCRIPTION
	348-1154-00	B010100	B010293	4	FOOT,CABINET:EARTH BROWN,PLASTIC	QJR05	348-1154-00
	348-1297-00	B010294		4	FOOT,CABINET:TEK BLUE,PLASTIC	QJR05	ORDER BY DESCRIPTION
-3	213-0782-00	B010100	B020137	4	SCREW,TPG,TF:8-32 X 0.625,FILH,STL	83486	ORDER BY DESCRIPTION
	212-0091-00	B020138		4	SCREW,MACHINE:8-32 X 0.625,FILH,STL (3001MPX ONLY)	93907	ORDER BY DESCRIPTION
	213-0782-00	B010100	B030126	4	SCREW,TPG,TF:8-32 X 0.625,FILH,STL	83486	ORDER BY DESCRIPTION
	212-0091-00	B030127		4	SCREW,MACHINE:8-32 X 0.625,FILH,STL (3001HSM ONLY)	93907	ORDER BY DESCRIPTION
	213-0782-00	B010100	B010274	4	SCREW,TPG,TF:8-32 X 0.625,FILH,STL	83486	ORDER BY DESCRIPTION
	212-0091-00	B010275		4	SCREW,MACHINE:8-32 X 0.625,FILH,STL (2505 ONLY)	93907	ORDER BY DESCRIPTION
-4	386-6005-00	B010100	B030124	1	PANEL,P ASSY:ALUMINUM,	5Y400	386-6005-00
	386-6005-01	B030125	B039999	1	PANEL,P ASSY:ALUMINUM	5Y400	PER TEKTRONIX SPECS
	386-6349-00	B040100		1	PANEL,PROBE:ALUMINUM,BLUE (3001HSM ONLY)	5Y400	ORDER BY DESCRIPTION
	386-6005-01	B010100	B010293	1	PANEL,P ASSY:ALUMINUM	5Y400	PER TEKTRONIX SPECS
	386-6349-00	B010294		1	PANEL,PROBE:ALUMINUM,BLUE (2505 ONLY)	5Y400	ORDER BY DESCRIPTION
	136-1084-10	B010100	B010152	1	.SOCKET,PGA:PCB,;STR,180 POS,15 X 15.0.1	80009	136-1084-10
	136-1084-00	B010153		1	.SOCKET,PGA:PCB,;STR,181 POS,15 X 15.0.1 (3001HSM ONLY)	00779	916225-4
	198-5699-00	B010100	B019999	1	WIRE SET,ELEC:	TK2469	198-5699-00
	198-5699-01	B020100		1	WIRE SET,ELEC: (3001MPX ONLY)	TK2469	ORDER BY DESCRIPTION
	198-5699-00	B010100	B020177	1	WIRE SET,ELEC:	TK2469	198-5699-00
	198-5699-01	B020178		1	WIRE SET,ELEC: (3001HSM ONLY)	TK2469	ORDER BY DESCRIPTION
-4A	211-0504-00			1	SCREW,MACHINE:6-32 X 0.250,PNH,STL CD PL,POZ	TK0435	ORDER BY DESCRIPTION
-5	211-0489-00			6	SCREW,MACHINE:4-40 X 0.125,PNH,POZ,STL,CLPL	OKB01	211-0489-00
-6	367-0399-00	B010100	B029999	1	HANDLE,CARRYING:	62559	10592-045
	367-0444-00	B030100		1	HANDLE,CARRYING: (3001MPX ONLY)	62559	367-0444-00
	367-0399-00	B010100	B039999	1	HANDLE,CARRYING:	62559	10592-045
	367-0444-00	B040100		1	HANDLE,CARRYING: (3001HSM ONLY)	62559	367-0444-00
	367-0399-00	B010100	B010293	1	HANDLE,CARRYING:	62559	10592-045
	367-0444-00	B010294		1	HANDLE,CARRYING: (2505 ONLY)	62559	367-0444-00
-7	212-0179-00	B010100	B010226	2	SCREW,MACHINE:M4 X 0.7 X 0.18MM	OKB01	212-0179-00
	212-0173-00	B010227		2	SCREW,MACHINE:4 M X 0.7 X 20 MM (3001MPX ONLY)	OKB01	212-0173-00
	212-0179-00	B010100	B020137	2	SCREW,MACHINE:M4 X 0.7 X 0.18MM	OKB01	212-0179-00
	212-0173-00	B0020138		2	SCREW,MACHINE:4 M X 0.7 X 20 MM (3001HSM ONLY)	OKB01	212-0173-00
	212-0179-00	B010100	B010196	2	SCREW,MACHINE:M4 X 0.7 X 0.18MM	OKB01	212-0179-00
	212-0173-00	B010197		2	SCREW,MACHINE:4 M X 0.7 X 20 MM (2505 ONLY)	OKB01	212-0173-00
-8	220-0110-00			2	NUT:4M X 0.7,6.8 SQ	OKB01	220-0110-00
-9	210-1441-00			2	NUT,PL,ASSEM WA:4MM X 7MM	OKB01	TO BE ASSIGNED

Replaceable Mechanical Parts

REPLACEABLE MECHANICAL PARTS

Fig. & Index No.	Tektronix Part Number	Serial Number Effect	Discont	Qty	12345 Part Name & Description	Mfr Code	Mfr Part Number
1 -10	348-0080-01			4	FOOT,CABINET:CHARCOAL GRAY,POLYURETHANE	0JRO5	ORDER BY DESCRIPTION
-11	342-0911-00			1	INSULATOR,ELEC:LEXAN,0.01	2K262	342-0911-00
-12	101-0128-00			1	TRIM,DECORATIVE:3001MPX,FACADE	0JRO5	101-0128-00
-13	220-0743-00			6	NUT,STAMPED:0.187 ID X 0.375 HEX,STL CD PL	80009	220-0743-00
-14	334-7632-00			1	MARKER,IDENT:MARKED FACADE	07416	334-7632-00
-15	119-3475-00			1	KEYBOARD ASSY:3001HSM/MPM/MPX (3001 ONLY)	59666	9372-00036-301
15A	119-3513-00			1	KEYBOARD ASSY:HELVETICA KEYCAP (2505 ONLY)	59666	ORDER BY DESCRIPTION
-16	211-0008-00			2	SCREW,MACHINE:4-40 X 0.25,PNH,STL	93907	ORDER BY DESCRIPTION
17	262-1033-00	B010100	B010111	1	SWITCH ASSEMBLY:8PST,FLEX CIRCUIT	07416	262-1033-00
	262-1033-01	B010112		1	SWITCH ASSEMBLY:SPST,FLEX CIRCUIT (3001MPM ONLY)	07416	262-1033-01
	262-1033-00	B010100	B010172	1	SWITCH ASSEMBLY:8PST,FLEX CIRCUIT	07416	262-1033-00
	262-1033-01	B010173	B020126	1	SWITCH ASSEMBLY:SPST,FLEX CIRCUIT	07416	262-1033-01
	262-1033-02	B020127		1	SWITCH ASSEMBLY:SPST,FLEX CIRCUIT (3001MPX ONLY)	07416	262-1033-02
	262-1033-01	B010100	B030124	1	SWITCH ASSEMBLY:SPST,FLEX CIRCUIT	07416	262-1033-01
	262-1033-02	B010125		1	SWITCH ASSEMBLY:SPST,FLEX CIRCUIT (3001HSM ONLY)	07416	262-1033-02
	262-1033-01	B010100	B030274	1	SWITCH ASSEMBLY:SPST,FLEX CIRCUIT	07416	262-1033-01
	262-1033-02	B010275		1	SWITCH ASSEMBLY:SPST,FLEX CIRCUIT (2505 ONLY)	07416	262-1033-02
-18	671-0058-51	B010100	B010113	1	CIRCUIT BD ASSY:MPU	80009	671-0058-51
	671-0058-52	B010114	B010125	1	CIRCUIT BD ASSY:MPU	80009	671-0058-52
	671-0058-53	B010126	B010128	1	CIRCUIT BD ASST:MPU	80009	671-0058-53
	671-0058-54	B010129		1	CIRCUIT BD ASSY:MPU (3001MPM) REFER TO 070-7413-XX FOR DETAILS)	80009	671-0058-54
	671-0058-51	B010100	B010174	1	CIRCUIT BD ASSY:MPU	80009	671-0058-51
	671-0058-52	B010175	B010190	1	CIRCUIT BD ASSY:MPU	80009	671-0058-52
	671-0058-53	B010191	B010209	1	CIRCUIT BD ASST:MPU	80009	671-0058-53
	671-0058-54	B010210	B019999	1	CIRCUIT BD ASSY:MPU	80009	671-0058-54
	671-0058-55	B020100	B029999	1	CIRCUIT BD ASSY:MPU	80009	671-0058-55
	671-0058-56	B030100	B040104	1	CIRCUIT BD ASSY:MPU	80009	671-0058-56
	671-0058-57	B040105	B049999	1	CIRCUIT BD ASSY:MPU	80009	671-0058-57
	671-0058-58	B050100		1	CIRCUIT BD ASSY:MPU (3001MPX) REFER TO 070-7413-XX FOR DETAILS)	80009	671-0058-58
	671-0058-52	B010100	B010140	1	CIRCUIT BD ASSY:MPU	80009	671-0058-52
	671-0058-53	B010141	B010159	1	CIRCUIT BD ASST:MPU	80009	671-0058-53
	671-0058-54	B010160	B029999	1	CIRCUIT BD ASSY:MPU	80009	671-0058-54
	671-0058-55	B030100	B039999	1	CIRCUIT BD ASSY:MPU	80009	671-0058-55
	671-0058-56	B040100	B049999	1	CIRCUIT BD ASSY:MPU	80009	671-0058-56
	671-0058-57	B050100	B059999	1	CIRCUIT BD ASSY:MPU	80009	671-0058-57
	671-0058-58	B060100		1	CIRCUIT BD ASSY:MPU (3001HSM) REFER TO 070-7413-XX FOR DETAILS)	80009	671-0058-58
	671-0058-56	B010100	B010169	1	CIRCUIT BD ASSY:MPU	80009	671-0058-56
	671-0058-57	B010170	B019999	1	CIRCUIT BD ASSY:MPU	80009	671-0058-57
	671-0058-58	B020100		1	CIRCUIT BD ASSY:MPU (3001GPX 1M REFER TO 070-8354-XX FOR DETAILS)	80009	671-0058-58
	671-0058-54	B010100	B010248	1	CIRCUIT BD ASSY:MPU	80009	671-0058-54
	671-0058-55	B010249	B010281	1	CIRCUIT BD ASSY:MPU	80009	671-0058-55
	671-0058-56	B010282	B010287	1	CIRCUIT BD ASSY:MPU	80009	671-0058-56
	671-0058-57	B010288	B019999	1	CIRCUIT BD ASSY:MPU	80009	671-0058-57
	671-0058-58	B020100		1	CIRCUIT BD ASSY:MPU (2505 ONLY)	80009	671-0058-58
-19	407-3916-00			1	BRKT,CKT BD:ALUMINUM,MPU MTG	5Y400	407-3916-00
-20	211-0504-00			5	SCREW,MACHINE:6-32 X 0.250,PNH,STL	TK0435	ORDER BY DESCRIPTION
-21	346-0120-00			5	STRAP,TIEDOWN,E:5.5 L MIN,PLASTIC,WHITE	06383	SST1.5M
-22	671-1372-00			1	CIRCUIT BD ASSY:3001MPX KEYBOARD	80009	671-1372-00
-23	210-0586-00			2	NUT,PL,ASSEM WA:4-40 X 0.25,STL CD PL	OKB01	ORDER BY DESCRIPTION
-24	211-0097-00			2	SCREW,MACHINE:4-40 X 0.312,PNH,STL	93907	ORDER BY DESCRIPTION

REPLACEABLE MECHANICAL PARTS

Fig. & Index No.	Tektronix Part Number	Serial Number Effect	Discont	Qty	12345 Part Name & Description	Mfr Code	Mfr Part Number
1 -25	671-1371-00	B010100	B039999	1	CIRCUIT BD ASSY:3001MPX CONNECTOR	80009	671-1371-00
	671-1371-01	B040100		1	CIRCUIT BD ASSY:3001MPX CONNECTOR (3001HSM ONLY)	80009	671-1371-00
	671-1371-00	B010100	B039999	1	CIRCUIT BD ASSY:3001MPX CONNECTOR	80009	671-1371-00
	671-1371-01	B0401000		1	CIRCUIT BD ASSY:3001MPX CONNECTOR (3001MPX ONLY)	80009	671-1371-00
	671-1371-00	B010100	B010293	1	CIRCUIT BD ASSY:3001MPX CONNECTOR	80009	671-1371-00
	671-1371-01	B010294		1	CIRCUIT BD ASSY:3001MPX CONNECTOR (2505 ONLY)	80009	671-1371-00
	-25A	211-0244-00		2	SCR,ASSEM WSHR:4-40 X 0.312,PNH,STL,CD PL	01536	821-02775
	-25B	344-0457-00		2	CLIP,RETAINER:ALUMINUM	5Y400	344-0457-00
	-25C	210-3057-00		2	WASHER,FLAT:0.17 ID X 0.375 OD X 0.03 THK.	OKB01	LWNY-012NA-M
	-26	441-1918-00	B010100	B010114	1	CHASSIS,MAIN:3001	QJ260
	441-1918-01	B010115	B010136	1	CHASSIS,MAIN:3001	QJ260	441-1918-01
	441-1918-02	B010137		1	CHASSIS,MAIN:3001 (3001MPM ONLY)	QJ260	441-191802
	441-1918-00	B010100	B010179	1	CHASSIS,MAIN:3001	QJ260	441-1918-00
	441-1918-01	B010180	B010237	1	CHASSIS,MAIN:3001	QJ260	441-1918-01
	441-1918-02	B010238	B010276	1	CHASSIS,MAIN:3001	QJ260	441-1918-02
	441-1918-03	B010277		1	CHASSIS,MAIN:3001 (3001MPX ONLY)	QJ9P9	441-1918-03
	441-1918-01	B010100	B010197	1	CHASSIS,MAIN:3001	QJ260	441-1918-01
	441-1918-02	B010198	B020143	1	CHASSIS,MAIN:3001	QJ260	441-1918-02
	441-1918-03	B020144		1	CHASSIS,MAIN:3001 (3001HSM ONLY)	QJ9P9	441-1918-03
	441-1918-02	B010100	B030107	1	CHASSIS,MAIN:3001	QJ260	441-1918-02
	441-1918-03	B030108		1	CHASSIS,MAIN:3001 (3001HSM 1M ONLY)	QJ9P9	441-1918-03
	441-1918-02	B010100	B010293	1	CHASSIS,MAIN:3001	QJ260	441-1918-02
	441-1918-03	B010294		1	CHASSIS,MAIN:3001 (2505 ONLY)	QJ9P9	441-1918-03
-27	386-6112-00	B010100	B020143	1	PANEL,REAR:3001	QJ260	386-6112-00
	386-6112-01	B020144		1	PANEL,REAR:3001 (3001HSM ONLY)	QJ9P9	386-6112-01
	386-6112-00	B010115		1	PANEL,REAR:3001 (3001MPM ONLY)	QJ260	386-6112-00
	386-6112-00	B010100	B030107	1	PANEL,REAR:3001	QJ260	386-6112-00
	386-6112-01	B030108		1	PANEL,REAR:3001 (3001HSM 1M ONLY)	QJ9P9	386-6112-01
	386-6112-00			1	PANEL,REAR:3001 (2505 ONLY)	QJ260	386-6112-00
-28	211-0504-00			6	.SCREW,MACHINE:6-32 X 0.250,PNH,STL	TK0435	ORDER BY DESCRIPTION
-29	348-0516-00			7	GROMMET,PLASTIC:BLACK,ROUND,0.188 ID	28520	SB312-3
-30	200-3803-00			1	COVER,CABLE:POLYCARBONATE	5Y400	200-3803-00
-31	407-3959-00			1	BRACKET,SUPPORT:POWER SUPPLY,ALUMINUM	5Y400	407-3959-00
-32	212-0004-00			1	SCREW,MACHINE:8-32 X 0.312,PNH,STL	TK0435	ORDER BY DESCRIPTION
-33	211-0504-00			2	SCREW,MACHINE:6-32 X 0.250,PNH,STL	TK0435	ORDER BY DESCRIPTION
-34	337-3644-00			1	SHIELD,CRT:ALUMINUM,	5Y400	337-3644-00
-35	211-0504-00			4	SCREW,MACHINE:6-32 X 0.250,PNH,STL	TK0435	ORDER BY DESCRIPTION
-36	334-7824-00			1	MARKER,IDENT:MKD DANGER CRT SHIELD	07416	334-7824-00
-37	358-0166-00			1	GROMMET,PLASTIC:BLACK,U-SHAPE,0.656 ID	80009	358-0166-00
-38	348-0141-00			1	GROMMET,PLASTIC:BLACK,U-SHAPE,0.524	QJ905	ORDER BY DESCRIPTION
-39	252-0571-00	B010100	B010114	AR	NEOPRENE EXTR:CHAN,0.234 X 0.156 (3001MPM ONLY)	85471	ORDER BY DESCRIPTION
	252-0571-00	B010100	B010179	AR	NEOPRENE EXTR:CHAN,0.234 X 0.156 (3001MPX ONLY)	85471	ORDER BY DESCRIPTION
-40	255-0689-00	B010115		AR	PLASTIC CHANNEL:0.094 W X 3.25 L (3001MPM ONLY)	06915	SPGS-2
	255-0689-00	B010180		AR	PLASTIC CHANNEL:0.094 W X 3.25 L (3001MPX ONLY)	06915	SPGS-2

Replaceable Mechanical Parts

REPLACEABLE MECHANICAL PARTS

Fig. & Index No.	Tektronix Part Number	Serial Number Effect	Serial Number Discnt	Qty	12345 Part Name & Description	Mfr Code	Mfr Part Number
1 -41	119-3582-00	B030100	B039999	1	CRT DISPLAY AS:9 INCH CHASSIS,TTL P31	17954	7-030-0403
	119-4444-00	B040100		1	CRT DISPLAY:9 INCH CHASSIS,TTL P4 PHOSPH (3001HSM ONLY)	54972	CE663PAMGAD
	119-3582-00	B020100	B029999	1	CRT DISPLAY AS:9 INCH CHASSIS,TTL P31	17954	7-030-0403
	119-4444-00	B030100		1	CRT DISPLAY:9 INCH CHASSIS,TTL P4 PHOSPH (3001MPX ONLY)	54972	CE663PAMGAD
	119-3582-00			1	CRT DISPLAY AS:9 INCH CHASSIS,TTL P31 (3001MPM ONLY)	17954	7-030-0403
	119-3582-00			1	CRT DISPLAY AS:9 INCH CHASSIS,TTL P31 (2505 ONLY)	17954	7-030-0403
-42	212-0004-00			4	SCREW,MACHINE:8-32 X 0.312,PNH,STL	TK0435	ORDER BY DESCRIPTION
-43	118-8503-00			1	CIRCUIT BD ASSY:CRT DRIVE BOARD FROM	17954	6-002-1679
-44	211-0658-00			4	SCR,ASSEM WSHR:6-32 X 0.312,PNH,STL,POZ	78189	S51-060545-0X
-45	348-0430-00			3	BUMPER,PLASTIC:BLACK POLYURETHANE	2K262	ORDER BY DESCRIPTION
-46	119-1725-01			1	FAN,TUBEAXIAL:8 14.5VDC,6W,3200RPM,106CFM	2W944	4112 KX
-47	211-0511-00			4	SCREW,MACHINE:6-32 X 0.5,PNH,STL	TK0435	ORDER BY DESCRIPTION
-48	220-0155-00			4	NUT,SHEET SPR:6-32,U TYPE,STL,PHOS	TK1423	C53635-632-4
-49	671-1373-00	B010100	B039999	1	CIRCUIT BD ASSY:3001MPX PWR	80009	671-1373-00
	671-1373-01	B040100		1	CIRCUIT BD ASSY:3001MPX PWR (3001HSM ONLY)	80009	671-1373-01
	671-1373-00	B010100	B039999	1	CIRCUIT BD ASSY:3001MPX PWR	80009	671-1373-00
	671-1373-01	B040100		1	CIRCUIT BD ASSY:3001MPX PWR (3001MPX ONLY)	80009	671-1373-01
	671-1373-00			1	CIRCUIT BD ASSY:3001MPX PWR (2505 ONLY)	80009	671-1373-00
	671-1373-01			1	CIRCUIT BD ASSY:3001MPX PWR (2505 ONLY)	80009	671-1373-01
-50	211-0658-00			6	SCR,ASSEM WSHR:6-32 X 0.312,PNH,STL,POZ	78189	S51-060545-0X
-51	131-2427-00			26	TERM,01K DISC, PCB,MALE TAB,0.250 X 0.032,	00779	62409
-52	148-1017-00			1	RELAY,ARMATURE 2 FORM C,10A,240VAC,COIL	12300	KUIP-11D55-12
-53	211-0724-00			2	SCREW,MACHINE 6-32 X 0.375,PNH POZ	01536	ORDER BY DESCRIPTION
-54	210-0870-00			4	WASHER,FLAT 0.141 ID X 0.312 OD X 0.05,	12327	ORDER BY DESCRIPTION
-55	210-0457-00			2	NUT,PL,ASSEM WA6-32 X 0.312,STL CD PL	0K801	ORDER BY DESCRIPTION
-56	200-3790-00	B010100	B010117	1	COVER,PWR SPLY:ALUMINUM,	0J260	200-3790-00
	200-3790-01	B010118		1	COVER,PWR SPLY:ALUMINUM, (3001MPM ONLY)	5Y400	200-3790-01
	200-3790-00	B010100	B010180	1	COVER,PWR SPLY:ALUMINUM,	0J260	200-3790-00
	200-3790-01	B010181		1	COVER,PWR SPLY:ALUMINUM, (3001MPX ONLY)	5Y400	200-3790-01
	200-3790-01			1	COVER,PWR SPLY:ALUMINUM, (3001HSM & 2505 ONLY)	5Y400	200-3790-01
-57	211-0038-00			4	SCREW,MACHINE:4-40 X 0.312,FLH,100 DEG,STL	93907	ORDER BY DESCRIPTION
-58	334-6260-00			1	MARKER,IDENT:MKD POWER SUPPLY SHIELD	07416	PER TEKTRONIX DRAWIN
-59	348-0005-00			1	GROMMET,RUBBER:BLACK,ROUND,0.375 ID	70485	230X-36017
-60	119-3462-00	B010100	B060104	1	POWER SUPPLY:5V,20A,115/230VAC	TK1475	SQV140-1222-2(20-000
	119-3462-01	B060105		1	POWER SUPPLY:5V,20A,115/230VAC (3001 HSM ONLY)	TK1475	SQV140-1222-2(20-000
	119-3462-00	B010100	B050111	1	POWER SUPPLY:5V,20A,115/230VAC	TK1475	SQV140-1222-2(20-000
	119-3462-01	B060105		1	POWER SUPPLY:5V,20A,115/230VAC (3001 MPX ONLY)	TK1475	SQV140-1222-2(20-000
	119-3462-00	B010100	B020273	1	POWER SUPPLY:5V,20A,115/230VAC	TK1475	SQV140-1222-2(20-000
	119-3462-01	B020274		1	POWER SUPPLY:5V,20A,115/230VAC (3001 GPX ONLY)	TK1475	SQV140-1222-2(20-000
	119-3462-00	B010100	B020110	1	POWER SUPPLY:5V,20A,115/230VAC	TK1475	SQV140-1222-2(20-000
	119-3462-01	B020274		1	POWER SUPPLY:5V,20A,115/230VAC (2505 ONLY)	TK1475	SQV140-1222-2(20-000
-61	212-0004-00			4	SCREW,MACHINE:8-32 X 0.312,PNH,STL	TK0435	ORDER BY DESCRIPTION
-62	343-0775-00			2	CLIP,SPR TNSN:	52152	3484-1000
-63	174-1765-00			1	CA ASSY,SP,ELEC:20,26 AWG,28.5 L	TK2469	174-1765-00
-64	210-0590-00			2	NUT,PLAIN,HEX:0.375-32 X 0.438 BRS CD PL	73743	28269-402
-65	210-0012-00			1	WASHER,LOCK:0.384 ID,INTL,0.022 THK,STL	78189	1220-02-00-0541C
-66	260-2501-00			1	SWITCH,ROCKER:DPDT,30MA,12V	7W718	1804.1153
-67	260-1967-00			1	SWITCH,SLIDE:DPDT 5A/250V 10A/125V	7W718	4021.0512
-68	210-0586-00			2	NUT,PL,ASSEM WA:4-40 X 0.25,STL CD PL	0K801	ORDER BY DESCRIPTION
-69	211-0097-00			2	SCREW,MACHINE:4-40 X 0.312,PNH,STL	93907	ORDER BY DESCRIPTION

REPLACEABLE MECHANICAL PARTS

Fig. & Index No.	Tektronix Part Number	Serial Number Effect	Discont	Qty	12345 Part Name & Description	Mfr Code	Mfr Part Number
1 -69	211-0097-00			2	SCREW,MACHINE:4-40 X 0.312,PNH,STL	93907	ORDER BY DESCRIPTION
-70	204-0833-00			1	BODY,FUSEHOLDER:3AG & 5 X 20MM FUSES	S3629	031 1653 (MODEL FEU)
-71	200-2264-00			1	CAP,FUSEHOLDER 3AG FUSES	S3629	FEK 0311666
-72	159-0015-00			1	FUSE,CARTRIDGE:3AG,3A,250V,0.65SEC	75915	312 003
	159-0021-00			1	FUSE,CARTRIDGE:3AG,2A,250V,FAST BLOW	71400	AGC-2
-73	119-3745-00			1	FILTER,RFD:LINE,3A,250V,PANEL MOUNT	TK0196	119-3745-00
-74	211-0504-00			2	SCREW,MACHINE:6-32 X 0.250,PNH,STL	TK0435	ORDER BY DESCRIPTION
-75	348-0430-00			2	BUMPER,PLASTIC:BLACK POLYURETHANE	2K262	ORDER BY DESCRIPTION
-76	131-0031-00			1	JACK,TIP:BANANA,NON-INSULATED	74970	108-0740-023
-77	210-0455-00			1	NUT,PLAIN,HEX:0.25-28 X 0.375,BRS NP	73743	3089-402
-78	210-0046-00			1	WASHER,LOCK:0.261 ID,INTL,0.018 THK,STL	78189	1214-05-00-0541C
-79	334-3379-01			1	MARKER,IDENT:MARKED GROUND SYMBOL	22670	ORDER BY DESCRIPTION
-80	210-0457-00			3	NUT,PL,ASSEM WA:6-32 X 0.312,STL CD PL	0KB01	ORDER BY DESCRIPTION
81	671-0071-02	B010100	B010107	1	CIRCUIT BD ASSY:30MM,	80009	671-0071-02
	671-0071-03	B010108		1	CIRCUIT BD ASSY:30MM, (3001MPM ONLY)	80009	671-0071-03
	671-0069-00	B010100	B010152	1	CIRCUIT BD ASSY:HSM	80009	671-0069-00
	671-0069-01	B010153	B010164	1	CIRCUIT BD ASSY:30HSM	80009	671-0069-01
	671-0069-02	B010165	B019999	1	CIRCUIT BD ASSY:30HSM	80009	671-0069-02
	671-0069-03	B020100	B020173	1	CIRCUIT BD ASSY:30HSM	80009	671-0069-03
	671-0069-04	B020174		1	CIRCUIT BD ASSY:30HSM (3001HSM ONLY)	80009	671-0069-04
	671-0070-02	B010100	B010156	1	CIRCUIT BD ASSY:30MPX,	80009	671-0070-02
	671-0070-03	B010157		1	CIRCUIT BD ASSY:30MPX, (3001MPX REFER TO 070-6677-XX)	80009	671-0070-03
82	211-0246-00			11	SCR,ASSEM WSHR:4-40 X 0.625,PNH,STL,CD PL	01536	ORDER BY DESCRIPTION
-83	119-2571-00	B010100	B060102	1	DISK DRIVE:FLOPPY,;3.5 INCH,1.0 MEGABYTE	50356	FD-235F-311-2
	119-2571-01	B060103	B060111	1	DISK DRIVE:FLOPPY,;3.5 INCH,1.0 MEGABYTE	50356	FD-235F-311-2
	119-4561-00	B060112		1	DISK DRIVE:FLOPPY,;3.5 INCH,1.0 MEGABYTE (3001HSM ONLY)	50356	FD-235F-311-2
	119-2571-00	B010100	B050110	1	DISK DRIVE:FLOPPY,;3.5 INCH,1.0 MEGABYTE	50356	FD-235F-311-2
	119-2571-01	B050111	B050130	1	DISK DRIVE:FLOPPY,;3.5 INCH,1.0 MEGABYTE	50356	FD-235F-311-2
	119-4561-00	B050131		1	DISK DRIVE:FLOPPY,;3.5 INCH,1.0 MEGABYTE (3001MPX ONLY)	50356	FD-235F-311-2
	119-2571-00	B010100	B020235	1	DISK DRIVE:FLOPPY,;3.5 INCH,1.0 MEGABYTE	50356	FD-235F-311-2
	119-2571-01	B020236	B030230	1	DISK DRIVE:FLOPPY,;3.5 INCH,1.0 MEGABYTE	50356	FD-235F-311-2
	119-4561-00	B030241		1	DISK DRIVE:FLOPPY,;3.5 INCH,1.0 MEGABYTE (3001GPX ONLY)	50356	FD-235F-311-2
	119-2571-00	B010100	B020110	1	DISK DRIVE:FLOPPY,;3.5 INCH,1.0 MEGABYTE	50356	FD-235F-311-2
	119-2571-01	B020111	B020124	1	DISK DRIVE:FLOPPY,;3.5 INCH,1.0 MEGABYTE	50356	FD-235F-311-2
	119-4561-00	B020125		1	DISK DRIVE:FLOPPY,;3.5 INCH,1.0 MEGABYTE (2505 ONLY)	50356	FD-235F-311-2
-84	211-0328-00			4	SCREW,MACHINE:M3 X 0.5 X 10MM L,FLH,90 DEG	TK1123	ORDER BY DESCRIPTION
-85	348-0910-00			10	FOOT,CKT BD HSG	52152	SJ5007
-86	348-1163-00			6	SHLD GSKT,ELEK:EMI,GASKETING,CADMIUM PLATED	30817	493-48
-87	670-9664-01	B010283	B019999	1	CIRCUIT BD ASSY:HARD DISK CONTROLLER	80009	670-9664-01
	670-9664-02	B020100	B049999	1	CIRCUIT BD ASSY:HARD DISK CONTROLLER (3001MPX 1M ONLY)	80009	670-9664-02
	670-9664-01	B020164	B029999	1	CIRCUIT BD ASSY:HARD DISK CONTROLLER	80009	670-9664-01
	670-9664-02	B030100	B059999	1	CIRCUIT BD ASSY:HARD DISK CONTROLLER (3001HSM 1M ONLY)	80009	670-9664-02
	670-9664-02	B010100	B029999	1	CIRCUIT BD ASSY:HARD DISK CONTROLLER (3001GPX 1M ONLY)	80009	670-9664-02
-88	211-0658-00	B010283	B049999	4	SCR,ASSEM WSHR:6-32 X 0.312,PNH,STL,POZ (3001MPX 1M ONLY)	78189	S51-060545-0X
	211-0658-00	B020164	B059999	4	SCR,ASSEM WSHR:6-32 X 0.312,PNH,STL,POZ (3001HSM 1M ONLY)	78189	S51-060545-0X
	211-0658-00	B010100	B019999	4	SCR,ASSEM WSHR:6-32 X 0.312,PNH,STL,POZ (3001GPX 1M ONLY)	78189	S51-060545-0X
	211-0658-00	B010100	B019999	4	SCR,ASSEM WSHR:6-32 X 0.312,PNH,STL,POZ (2505 ONLY)	78189	S51-060545-0X

Replaceable Mechanical Parts

REPLACEABLE MECHANICAL PARTS

Fig. & Index No.	Tektronix Part Number	Serial Number Effect	Number Discont	Qty	12345 Part Name & Description	Mfr Code	Mfr Part Number
1 -89	174-0591-00	B010283	B049999	1	CA ASSY, SP, ELEC: 20, 28 AWG, 3.5 L, RIBBON (3001MPX 1M ONLY)	TK2469	174-0591-00
	174-0591-00	B020164	B059999	1	CA ASSY, SP, ELEC: 20, 28 AWG, 3.5 L, RIBBON (3001HSM 1M ONLY)	TK2469	174-0591-00
	174-0591-00	B010100	B019999	1	CA ASSY, SP, ELEC: 20, 28 AWG, 3.5 L, RIBBON (2505 ONLY)	TK2469	174-0591-00
-90	174-0594-00	B010283	B049999	1	CA ASSY, SP, ELEC: 34, 28 AWG, 3.50 L, RIBBON (3001MPX 1M ONLY)	TK2469	174-0594-00
	174-0594-00	B020164	B059999	1	CA ASSY, SP, ELEC: 34, 28 AWG, 3.50 L, RIBBON (3001HSM 1M ONLY)	TK2469	174-0594-00
	174-0594-00	B010100	B0199999	1	CA ASSY, SP, ELEC: 34, 28 AWG, 3.50 L, RIBBON (2505 ONLY)	TK2469	174-0594-00
	174-0594-00	B010100	B0199999	1	CA ASSY, SP, ELEC: 34, 28 AWG, 3.50 L, RIBBON (3001GPX 1M ONLY)	TK2469	174-0594-00
-91	174-2064-00	B010283		1	CA ASSY, SP, ELEC: 10, 28 AWG, 16.0 L, RIBBON (3001MPX 1M ONLY)	80009	174-2064-00
	174-2064-00	B020164		1	CA ASSY, SP, ELEC: 10, 28 AWG, 16.0 L, RIBBON (3001HSM 1M ONLY)	80009	174-2064-00
	174-2064-00			1	CA ASSY, SP, ELEC: 10, 28 AWG, 16.0 L, RIBBON (2505 ONLY)	80009	174-2064-00
-92	174-0590-01	B010283	B049999	1	CA ASSY, SP, ELEC: 4, 18 AWG, 14.0 L, RIBBON (3001MPX 1M ONLY)	TK2469	174-0590-01
	174-0590-01	B020164	B059999	1	CA ASSY, SP, ELEC: 4, 18 AWG, 14.0 L, RIBBON (3001HSM 1M ONLY)	TK2469	174-0590-01
	174-0590-01	B010100	B019999	1	CA ASSY, SP, ELEC: 4, 18 AWG, 14.0 L, RIBBON (2505 ONLY)	TK2469	174-0590-01
	174-0590-01	B010100	B019999	1	CA ASSY, SP, ELEC: 4, 18 AWG, 14.0 L, RIBBON (3001GPX 1M ONLY)	TK2469	174-0590-01
-93	174-2065-00	B010283		1	CA ASSY, SP, ELEC: 40, 28 AWG, 18.5 L, RIBBON (3001MPX 1M ONLY)	80009	174-2065-00
	174-2065-00	B020164		1	CA ASSY, SP, ELEC: 40, 28 AWG, 18.5 L, RIBBON (3001HSM 1M ONLY)	80009	174-2065-00
	174-2065-00			1	CA ASSY, SP, ELEC: 40, 28 AWG, 18.5 L, RIBBON (2505 ONLY)	80009	174-2065-00
-94	386-5419-01	B010283	B020124	1	PLATE, MOUNTING: WINCH, SST	5Y400	386-5419-01
	386-5419-02	B020125		1	PLATE, MOUNTING: WINCH, SST (3001MPX 1M ONLY)	TK1465	386-5419-02
	386-5419-01	B020164	B030107	1	PLATE, MOUNTING: WINCH, SST	5Y400	386-5419-01
	386-5419-02	B030108		1	PLATE, MOUNTING: WINCH, SST (3001HSM 1M ONLY)	TK1465	386-5419-02
	386-5419-01	B010100	B010270	1	PLATE, MOUNTING: WINCH, SST	5Y400	386-5419-01
	386-5419-02	B010271		1	PLATE, MOUNTING: WINCH, SST (2505 ONLY)	TK1465	386-5419-02
-95	211-0658-00	B010283	B049999	4	SCR, ASSEM WSHR: 6-32 X 0.312, PNH, STL, POZ (3001MPX 1M ONLY)	78189	S51-060545-0X
	211-0658-00	B010100	B019999	4	SCR, ASSEM WSHR: 6-32 X 0.312, PNH, STL, POZ (3001GPX 1M ONLY)	78189	S51-060545-0X
	211-0658-00	B010100	B019999	4	SCR, ASSEM WSHR: 6-32 X 0.312, PNH, STL, POZ (2502 ONLY)	78189	S51-060545-0X
-96	119-2572-01	B010283	B020124	1	DISK DRIVE: WINCHESTER, HARD; 3.5 INCH 20 MEG	TK2437	KL-320
	119-4367-00	B020125	B049999	1	HARD DISK DRIVE: SEAGATE 3.5; 40MB, 24MS, W/O	65867	903001-030
	119-4483-00	B050100	B050130	1	DISK DRIVE: WINCHESTER, HARD; 2.5 INCH 64 MEG	65867	95066-4544
	119-4561-01	B050131		1	DISK DRIVE: WINCHESTER, HARD; 2.5 INCH 127 MEG (3001MPX 1M ONLY)	65867	ST9145AG
	119-2572-01	B020144	B030107	1	DISK DRIVE: WINCHESTER, HARD; 3.5 INCH 20 MEG	TK2437	KL-320
	119-4367-00	B030108	B059999	1	HARD DISK DRIVE: SEAGATE 3.5; 40MB, 24MS, W/O	65867	903001-030
	119-4483-00	B060100	B060112	1	DISK DRIVE: WINCHESTER, HARD; 2.5 INCH 64 MEG	65867	95066-4544
	119-4561-01	B060113		1	DISK DRIVE: WINCHESTER, HARD; 2.5 INCH 127 MEG (3001HSM 1M ONLY)	65867	ST9145AG
	118-7075-02	B010100	B010237	1	DISK DRIVE: WINCHESTER, HARD; 3.5 INCH 20 MEG	TK2437	KL-320
	119-4367-00	B010238	B019999	1	HARD DISK DRIVE: SEAGATE 3.5; 40MB, 24MS, W/O	65867	903001-030
	119-4483-00	B020100	B020126	1	DISK DRIVE: WINCHESTER, HARD; 2.5 INCH 64 MEG	65867	95066-4544
	119-4561-01	B020127		1	DISK DRIVE: WINCHESTER, HARD; 2.5 INCH 127 MEG (2505 OPTION 21 ONLY)	65867	ST9145AG

REPLACEABLE MECHANICAL PARTS

Fig. & Index No.	Tektronix Part Number	Serial Number Effect	Serial Number Discont	Qty	12345 Part Name & Description	Mfr Code	Mfr Part Number
	361-1618-00	B010238	B019999	4	SPACER, PLATE: 0.062 X 0.350 X 2.252 (2505 OPTION 21 ONLY)	80009	361-1618-00
	119-4367-00	B020125	B019999	1	HARD DISK DRIVE: SEAGATE 3.5; 40MB, 24MS, W/O	65867	903001-030
	119-4483-00	B020100	B030266	1	DISK DRIVE: WINCHESTER, HARD; 2.5 INCH 64 MEG	65867	95066-4544
	119-4561-01	B030266		1	DISK DRIVE: WINCHESTER, HARD; 2.5 INCH 127 MEG (3001GPX 1M ONLY)	65867	ST9145AG
-97	211-0503-00	B010283	B020124	4	SCREW, MACHINE: 6-32 X 0.188, PNH, STL	93907	ORDER BY DESCRIPTION
	211-0507-00	B020125		4	SCREW, MACHINE: 6-32 X 0.312, PNH, STL (3001MPX 1M ONLY)	OKB01	211-0507-00
	211-0503-00	B020164	B030107	4	SCREW, MACHINE: 6-32 X 0.188, PNH, STL	93907	ORDER BY DESCRIPTION
	211-0507-00	B030108		4	SCREW, MACHINE: 6-32 X 0.312, PNH, STL (3001HSM 1M ONLY)	OKB01	211-0507-00
	211-0711-00			4	SCR, ASSEM WSHR 6-32 X 0.25, PNH, STL, TORX, T15 (2505 ONLY)	01536	ORDER BY DESCRIPTION
-98	407-4067-00	B010283	B049999	1	BRKT, HARD DISK: MOUNTING, ALUMINUM (3001MPX 1M ONLY)	0J9P9	ORDER BY DESCRIPTION
	407-4067-00	B020164	B059999	1	BRKT, HARD DISK: MOUNTING, ALUMINUM (3001HSM 1M ONLY)	0J9P9	ORDER BY DESCRIPTION
	407-4067-00	B010100	B019999	1	BRKT, HARD DISK: MOUNTING, ALUMINUM (3001GPX 1M ONLY)	0J9P9	ORDER BY DESCRIPTION
	407-4067-00	B010100	B019999	1	BRKT, HARD DISK: MOUNTING, ALUMINUM (2505 ONLY)	0J9P9	ORDER BY DESCRIPTION
-99	211-0559-00	B010283		2	SCREW, MACHINE: 6-32 X 0.375, FLH, 100 DEG, STL (3001MPX 1M ONLY)	OKB01	ORDER BY DESCRIPTION
	211-0559-00	B020164		2	SCREW, MACHINE: 6-32 X 0.375, FLH, 100 DEG, STL (3001HSM 1M ONLY)	OKB01	ORDER BY DESCRIPTION
	211-0725-00			2	SCREW, MACHINE 6-32 X 0.375, FLH TORX (2505 ONLY)	01536	ORDER BY DESCRIPTION
-100	211-0658-00	B010283		2	SCR, ASSEM WSHR: 6-32 X 0.312, PNH, STL, POZ (3001MPX 1M ONLY)	78189	S51-060545-0X
	211-0658-00	B020164		2	SCR, ASSEM WSHR: 6-32 X 0.312, PNH, STL, POZ (3001HSM 1M ONLY)	78189	S51-060545-0X
	211-0711-00			2	SCR, ASSEM WSHR 6-32 X 0.25, PNH, STL, TORX, T15 (2505 ONLY)	01536	ORDER BY DESCRIPTION

Replaceable Mechanical Parts

REPLACEABLE MECHANICAL PARTS

Fig. & Index No.	Tektronix Part Number	Serial Number Effect	Serial Number Discnt	Qty	12345 Part Name & Description	Mfr Code	Mfr Part Number
2 -1	437-0397-00	B010100	B029999	1	CABINET:3001	QJ260	437-0397-00
	437-0440-00	B030100		1	CABINET:3001 (3001MPX ONLY)	QJ9P9	ORDER BY DESCRIPTION
	437-0397-00	B010100	B039999	1	CABINET:3001	QJ260	437-0397-00
	437-0440-00	B040100		1	CABINET:3001 (3001HSM ONLY)	QJ9P9	ORDER BY DESCRIPTION
	437-0397-00	B010100	B010293	1	CABINET:3001	QJ260	437-0397-00
	437-0440-00	B010294		1	CABINET:3001 (2505 ONLY)	QJ9P9	ORDER BY DESCRIPTION
-2	348-1154-00	B010100	B029999	4	FOOT,CABINET:EARTH BROWN,PLASTIC	QJR05	348-1154-00
	348-1297-00	B030100		4	FOOT,CABINET:TEK BLUE,PLASTIC (3001MPX ONLY)	QJR05	ORDER BY DESCRIPTION
	348-1154-00	B010100	B039999	4	FOOT,CABINET:EARTH BROWN,PLASTIC	QJR05	348-1154-00
	348-1297-00	B040100		4	FOOT,CABINET:TEK BLUE,PLASTIC (3001HSM ONLY)	QJR05	ORDER BY DESCRIPTION
	348-1154-00	B010100	B010293	4	FOOT,CABINET:EARTH BROWN,PLASTIC	QJR05	348-1154-00
	348-1297-00	B010294		4	FOOT,CABINET:TEK BLUE,PLASTIC	QJR05	ORDER BY DESCRIPTION
-3	213-0782-00	B010100	B020137	4	SCREW,TPG,TF:8-32 X 0.625,FILH,STL	83486	ORDER BY DESCRIPTION
	212-0091-00	B020138		4	SCREW,MACHINE:8-32 X 0.625,FILH,STL (3001MPX ONLY)	93907	ORDER BY DESCRIPTION
	213-0782-00	B010100	B030126	4	SCREW,TPG,TF:8-32 X 0.625,FILH,STL	83486	ORDER BY DESCRIPTION
	212-0091-00	B030127		4	SCREW,MACHINE:8-32 X 0.625,FILH,STL (3001HSM ONLY)	93907	ORDER BY DESCRIPTION
	213-0782-00	B010100	B010274	4	SCREW,TPG,TF:8-32 X 0.625,FILH,STL	83486	ORDER BY DESCRIPTION
	212-0091-00	B010275		4	SCREW,MACHINE:8-32 X 0.625,FILH,STL (2505 ONLY)	93907	ORDER BY DESCRIPTION
-4	386-6005-00	B010100	B030124	1	PANEL,P ASSY:ALUMINUM,	5Y400	386-6005-00
	386-6005-01	B030125	B039999	1	PANEL,P ASSY:ALUMINUM	5Y400	PER TEKTRONIX SPECS
	386-6349-00	B040100		1	PANEL,PROBE:ALUMINUM,BLUE (3001HSM ONLY)	5Y400	ORDER BY DESCRIPTION
	386-6005-01	B010100	B010293	1	PANEL,P ASSY:ALUMINUM	5Y400	PER TEKTRONIX SPECS
	386-6349-00	B010294		1	PANEL,PROBE:ALUMINUM,BLUE (2505 ONLY)	5Y400	ORDER BY DESCRIPTION
	136-1084-10	B010100	B010152	1	.SOCKET,PGA:PCB,;STR,180 POS,15 X 15,0.1	80009	136-1084-10
	136-1084-00	B010153		1	.SOCKET,PGA:PCB,;STR,181 POS,15 X 15,0.1 (3001HSM ONLY)	00779	916225-4
	198-5699-00	B010100	B019999	1	WIRE SET,ELEC:	TK2469	198-5699-00
	198-5699-01	B020100		1	WIRE SET,ELEC: (3001MPX ONLY)	TK2469	ORDER BY DESCRIPTION
	198-5699-00	B010100	B020177	1	WIRE SET,ELEC:	TK2469	198-5699-00
	198-5699-01	B020178		1	WIRE SET,ELEC: (3001HSM ONLY)	TK2469	ORDER BY DESCRIPTION
-4A	211-0504-00			1	SCREW,MACHINE:6-32 X 0.250,PNH,STL CD PL,POZ	TK0435	ORDER BY DESCRIPTION
-5	211-0489-00			6	SCREW,MACHINE:4-40 X 0.125,PNH,POZ,STL,CLPL	OKB01	211-0489-00
-6	367-0399-00	B010100	B029999	1	HANDLE,CARRYING:	62559	10592-045
	367-0444-00	B030100		1	HANDLE,CARRYING: (3001MPX ONLY)	62559	367-0444-00
	367-0399-00	B010100	B039999	1	HANDLE,CARRYING:	62559	10592-045
	367-0444-00	B040100		1	HANDLE,CARRYING: (3001HSM ONLY)	62559	367-0444-00
	367-0399-00	B010100	B010293	1	HANDLE,CARRYING:	62559	10592-045
	367-0444-00	B010294		1	HANDLE,CARRYING: (2505 ONLY)	62559	367-0444-00
-7	212-0179-00			2	SCREW,MACHINE:M4 X 0.7 X 0.18MM	OKB01	212-0179-00
-8	220-0110-00			2	NUT:4M X 0.7,6.8 SQ	OKB01	220-0110-00
-9	210-1441-00			2	NUT,PL,ASSEM WA:4MM X 7MM	OKB01	TO BE ASSIGNED
-10	348-0080-01			4	FOOT,CABINET:CHARCOAL GRAY,POLYURETHANE	QJR05	ORDER BY DESCRIPTION
-11	342-0911-00			1	INSULATOR,ELEC:LEXAN,0.01	2K262	342-0911-00
-12	101-0128-00			1	TRIM,DECORATIVE:3001MPX,FACADE	QJR05	101-0128-00
-13	220-0743-00			6	NUT,STAMPED:0.187 ID X 0.375 HEX,STL CD PL	80009	220-0743-00
-14	334-7632-00			1	MARKER,IDENT:MARKED FACADE	07416	334-7632-00
-15	119-3475-00			1	KEYBOARD ASSY:3001HSM/MPM/MPX (3001 ONLY)	59666	9372-00036-301

REPLACEABLE MECHANICAL PARTS

Fig. & Index No.	Tektronix Part Number	Serial Number Effect	Discont	Qty	12345 Part Name & Description	Mfr Code	Mfr Part Number
2 15A	119-3513-00			1	KEYBOARD ASSY:HELVETICA KEYCAP (2505 ONLY)	59666	ORDER BY DESCRIPTION
-16	211-0008-00			2	SCREW,MACHINE:4-40 X 0.25,PNH,STL	93907	ORDER BY DESCRIPTION
17	262-1033-00	B010100	B010111	1	SWITCH ASSEMBLY:8PST,FLEX CIRCUIT	07416	262-1033-00
	262-1033-01	B010112		1	SWITCH ASSEMBLY:SPST,FLEX CIRCUIT (3001MPM ONLY)	07416	262-1033-01
	262-1033-00	B010100	B010172	1	SWITCH ASSEMBLY:8PST,FLEX CIRCUIT	07416	262-1033-00
	262-1033-01	B010173	B020126	1	SWITCH ASSEMBLY:SPST,FLEX CIRCUIT	07416	262-1033-01
	262-1033-02	B020127		1	SWITCH ASSEMBLY:SPST,FLEX CIRCUIT (3001MPX ONLY)	07416	262-1033-02
	262-1033-01	B010100	B030124	1	SWITCH ASSEMBLY:SPST,FLEX CIRCUIT	07416	262-1033-01
	262-1033-02	B010125		1	SWITCH ASSEMBLY:SPST,FLEX CIRCUIT (3001HSM ONLY)	07416	262-1033-02
	262-1033-01	B010100	B030274	1	SWITCH ASSEMBLY:SPST,FLEX CIRCUIT	07416	262-1033-01
	262-1033-02	B010275		1	SWITCH ASSEMBLY:SPST,FLEX CIRCUIT (2505 ONLY)	07416	262-1033-02
-18	671-0058-51	B010100	B010113	1	CIRCUIT BD ASSY:MPU	80009	671-0058-51
	671-0058-52	B010114	B010125	1	CIRCUIT BD ASSY:MPU	80009	671-0058-52
	671-0058-53	B010126	B010128	1	CIRCUIT BD ASST:MPU	80009	671-0058-53
	671-0058-54	B010129		1	CIRCUIT BD ASSY:MPU (3001MPM) REFER TO 070-7413-XX FOR DETAILS)	80009	671-0058-54
	671-0058-51	B010100	B010174	1	CIRCUIT BD ASSY:MPU	80009	671-0058-51
	671-0058-52	B010175	B010190	1	CIRCUIT BD ASSY:MPU	80009	671-0058-52
	671-0058-53	B010191	B010209	1	CIRCUIT BD ASST:MPU	80009	671-0058-53
	671-0058-54	B010210	B019999	1	CIRCUIT BD ASSY:MPU	80009	671-0058-54
	671-0058-55	B020100	B029999	1	CIRCUIT BD ASSY:MPU	80009	671-0058-55
	671-0058-56	B030100	B040104	1	CIRCUIT BD ASSY:MPU	80009	671-0058-56
	671-0058-57	B040105	B049999	1	CIRCUIT BD ASSY:MPU	80009	671-0058-57
	671-0058-58	B050100		1	CIRCUIT BD ASSY:MPU (3001MPX) REFER TO 070-7413-XX FOR DETAILS)	80009	671-0058-58
	671-0058-52	B010100	B010140	1	CIRCUIT BD ASSY:MPU	80009	671-0058-52
	671-0058-53	B010141	B010159	1	CIRCUIT BD ASST:MPU	80009	671-0058-53
	671-0058-54	B010160	B029999	1	CIRCUIT BD ASSY:MPU	80009	671-0058-54
	671-0058-55	B030100	B039999	1	CIRCUIT BD ASSY:MPU	80009	671-0058-54
	671-0058-56	B040100	B049999	1	CIRCUIT BD ASSY:MPU	80009	671-0058-56
	671-0058-57	B050100	B059999	1	CIRCUIT BD ASSY:MPU	80009	671-0058-57
	671-0058-58	B060100		1	CIRCUIT BD ASSY:MPU (3001HSM) REFER TO 070-7413-XX FOR DETAILS)	80009	671-0058-58
	671-0058-56	B010100	B010169	1	CIRCUIT BD ASSY:MPU	80009	671-0058-56
	671-0058-57	B010170	B019999	1	CIRCUIT BD ASSY:MPU	80009	671-0058-57
	671-0058-58	B020100		1	CIRCUIT BD ASSY:MPU (3001GPX) REFER TO 070-8354-XX FOR DETAILS)	80009	671-0058-58
	671-0058-54	B010100	B010248	1	CIRCUIT BD ASSY:MPU	80009	671-0058-54
	671-0058-55	B010249	B010281	1	CIRCUIT BD ASSY:MPU	80009	671-0058-54
	671-0058-56	B010282	B010287	1	CIRCUIT BD ASSY:MPU	80009	671-0058-56
	671-0058-57	B010288	B019999	1	CIRCUIT BD ASSY:MPU	80009	671-0058-57
	671-0058-58	B020100		1	CIRCUIT BD ASSY:MPU (2505 ONLY)	80009	671-0058-58
-19	407-3916-00			1	,BRKT,CKT BD:ALUMINUM,MPU MTG	5Y400	407-3916-00
-20	211-0504-00			5	SCREW,MACHINE:6-32 X 0.250,PNH,STL	TK0435	ORDER BY DESCRIPTION
-21	346-0120-00			5	STRAP,TIEDOWN,E:5.5 L MIN,PLASTIC,WHITE	06383	SST1,5M
-22	671-1372-00			1	CIRCUIT BD ASSY:3001MPX KEYBOARD	80009	671-1372-00
-23	210-0586-00			2	NUT,PL,ASSEM WA:4-40 X 0.25,STL CD PL	OKB01	ORDER BY DESCRIPTION
-24	211-0097-00			2	SCREW,MACHINE:4-40 X 0.312,PNH,STL	93907	ORDER BY DESCRIPTION

Replaceable Mechanical Parts

REPLACEABLE MECHANICAL PARTS

Fig. & Index No.	Tektronix Part Number	Serial Effect	Number Discont	Qty	12345 Part Name & Description	Mfr Code	Mfr Part Number	
2 -25	671-1371-00	B010100	B039999	1	CIRCUIT BD ASSY:3001MPX CONNECTOR	80009	671-1371-00	
	671-1371-01	B040100		1	CIRCUIT BD ASSY:3001MPX CONNECTOR (3001HSM ONLY)	80009	671-1371-00	
	671-1371-00	B010100	B039999	1	CIRCUIT BD ASSY:3001MPX CONNECTOR	80009	671-1371-00	
	671-1371-01	B0401000		1	CIRCUIT BD ASSY:3001MPX CONNECTOR (3001MPX ONLY)	80009	671-1371-00	
	671-1371-00	B010100	B010293	1	CIRCUIT BD ASSY:3001MPX CONNECTOR	80009	671-1371-00	
	671-1371-01	B010294		1	CIRCUIT BD ASSY:3001MPX CONNECTOR (2505 ONLY)	80009	671-1371-00	
-25A	211-0244-00			2	SCR,ASSEM WSHR:4-40 X 0.312,PNH,STL,CD PL	01536	821-02775	
-25B	344-0457-00			2	CLIP,RETAINER:ALUMINUM	5Y400	344-0457-00	
-25C	210-3057-00			2	WASHER,FLAT:0.17 ID X 0.375 OD X 0.03 THK.	0KB01	LWNY-012NA-M	
-26	441-1918-00	B010100	B010114	1	CHASSIS,MAIN:3001	0J260	441-1918-00	
	441-1918-01	B010115	B010136	1	CHASSIS,MAIN:3001	0J260	441-1918-01	
	441-1918-02	B010137		1	CHASSIS,MAIN:3001 (3001MPM ONLY)	0J260	441-191802	
	441-1918-00	B010100	B010179	1	CHASSIS,MAIN:3001	0J260	441-1918-00	
	441-1918-01	B010180	B010237	1	CHASSIS,MAIN:3001	0J260	441-1918-01	
	441-1918-02	B010238	B010276	1	CHASSIS,MAIN:3001	0J260	441-1918-02	
	441-1918-03	B010277		1	CHASSIS,MAIN:3001 (3001MPX ONLY)	0J9P9	441-1918-03	
	441-1918-01	B010100	B010197	1	CHASSIS,MAIN:3001	0J260	441-1918-01	
	441-1918-02	B010198	B020143	1	CHASSIS,MAIN:3001	0J260	441-1918-02	
	441-1918-03	B020144		1	CHASSIS,MAIN:3001 (3001HSM ONLY)	0J9P9	441-1918-03	
	441-1918-02	B010100	B010293	1	CHASSIS,MAIN:3001	0J260	441-1918-02	
	441-1918-03	B010294		1	CHASSIS,MAIN:3001 (2505 ONLY)	0J9P9	441-1918-03	
	-27	386-6112-00	B010100	B020143	1	PANEL,REAR:3001	0J260	386-6112-00
		386-6112-01	B020144		1	PANEL,REAR:3001 (3001HSM ONLY)	0J9P9	386-6112-01
386-6112-00		B010115		1	PANEL,REAR:3001 (3001MPM ONLY)	0J260	386-6112-00	
386-6112-00		B010100	B030107	1	PANEL,REAR:3001	0J260	386-6112-00	
386-6112-01		B030108		1	PANEL,REAR:3001 (3001HSM 1M ONLY)	0J9P9	386-6112-01	
386-6112-00				1	PANEL,REAR:3001 (2505 ONLY)	0J260	386-6112-00	
-28	211-0504-00			6	SCREW,MACHINE:6-32 X 0.250,PNH,STL	TK0435	ORDER BY DESCRIPTION	
-29	348-0516-00			7	GROMMET,PLASTIC:BLACK,ROUND,0.188 ID	28520	SB312-3	
-30	200-3803-00			1	COVER,CABLE:POLYCARBONATE	5Y400	200-3803-00	
-31	407-3959-00			1	BRACKET,SUPPORT:POWER SUPPLY,ALUMINUM	5Y400	407-3959-00	
-32	212-0004-00			1	SCREW,MACHINE:8-32 X 0.312,PNH,STL	TK0435	ORDER BY DESCRIPTION	
-33	211-0504-00			2	SCREW,MACHINE:6-32 X 0.250,PNH,STL	TK0435	ORDER BY DESCRIPTION	
-34	337-3644-00			1	SHIELD,CRT:ALUMINUM,	5Y400	337-3644-00	
-35	211-0504-00			4	SCREW,MACHINE:6-32 X 0.250,PNH,STL	TK0435	ORDER BY DESCRIPTION	
-36	334-7824-00			1	MARKER,IDENT:MKD DANGER CRT SHIELD	07416	334-7824-00	
-37	358-0166-00			1	GROMMET,PLASTIC:BLACK,U-SHAPE,0.656 ID	80009	358-0166-00	
-38	348-0141-00			1	GROMMET,PLASTIC:BLACK,U-SHAPE,0.524	0J9R05	ORDER BY DESCRIPTION	
-39	252-0571-00	B010100	B010114	AR	NEOPRENE EXTR:CHAN,0.234 X 0.156 (3001MPM ONLY)	85471	ORDER BY DESCRIPTION	
	252-0571-00	B010100	B010179	AR	NEOPRENE EXTR:CHAN,0.234 X 0.156 (3001MPX ONLY)	85471	ORDER BY DESCRIPTION	
-40	255-0689-00	B010115		AR	PLASTIC CHANNEL:0.094 W X 3.25 L100 FT ROLL (3001MPM ONLY)	06915	SPGS-2	
	255-0689-00	B010180		AR	PLASTIC CHANNEL:0.094 W X 3.25 L100 FT ROLL (3001MPX ONLY)	06915	SPGS-2	

REPLACEABLE MECHANICAL PARTS

Fig. & Index No.	Tektronix Part Number	Serial Number Effect	Discont	Qty	12345 Part Name & Description	Mfr Code	Mfr Part Number
2 -41	119-3582-00	B030100	B039999	1	CRT DISPLAY AS:9 INCH CHASSIS,TTL P31	17954	7-030-0403
	119-4444-00	B040100		1	CRT DISPLAY:9 INCH CHASSIS,TTL P4 PHOSPH (3001HSM ONLY)	54972	CE663PAMGAD
	119-3582-00	B020100	B029999	1	CRT DISPLAY AS:9 INCH CHASSIS,TTL P31	17954	7-030-0403
	119-4444-00	B030100		1	CRT DISPLAY:9 INCH CHASSIS,TTL P4 PHOSPH (3001MPX ONLY)	54972	CE663PAMGAD
	119-3582-00			1	CRT DISPLAY AS:9 INCH CHASSIS,TTL P31 (3001MPM ONLY)	17954	7-030-0403
	119-3582-00			1	CRT DISPLAY AS:9 INCH CHASSIS,TTL P31 (2505 ONLY)	17954	7-030-0403
-42	212-0004-00			4	SCREW,MACHINE:8-32 X 0.312,PNH,STL	TK0435	ORDER BY DESCRIPTION
-43	118-8503-00			1	CIRCUIT BD ASSY:CRT DRIVE BOARD FROM	17954	6-002-1679
-44	211-0658-00			4	SCR,ASSEM WSHR:6-32 X 0.312,PNH,STL,POZ	78189	S51-060545-0X
-45	348-0430-00			3	BUMPER,PLASTIC:BLACK POLYURETHANE	2K262	ORDER BY DESCRIPTION
-46	119-1725-01			1	FAN,TUBEAXIAL:8 14.5VDC,6W,3200RPM,106CFM	2W944	4112 KX
-47	211-0511-00			4	SCREW,MACHINE:6-32 X 0.5,PNH,STL	TK0435	ORDER BY DESCRIPTION
-48	220-0155-00			4	NUT,SHEET SPR:6-32,U TYPE,STL,PHOS	TK1423	C53635-632-4
-49	671-1373-00	B010100	B039999	1	CIRCUIT BD ASSY:3001MPX PWR	80009	671-1373-00
	671-1373-01	B040100		1	CIRCUIT BD ASSY:3001MPX PWR (3001HSM ONLY)	80009	671-1373-01
	671-1373-00	B010100	B039999	1	CIRCUIT BD ASSY:3001MPX PWR	80009	671-1373-00
	671-1373-01	B040100		1	CIRCUIT BD ASSY:3001MPX PWR (3001MPX ONLY)	80009	671-1373-01
	671-1373-00			1	CIRCUIT BD ASSY:3001MPX PWR	80009	671-1373-00
	671-1373-01			1	CIRCUIT BD ASSY:3001MPX PWR (2505 ONLY)	80009	671-1373-01
-50	211-0658-00			6	SCR,ASSEM WSHR:6-32 X 0.312,PNH,STL,POZ	78189	S51-060545-0X
-51	131-2427-00			26	TERM,01K DISC. PCB,MALE TAB,0.250 X 0.032,	00779	62409
-52	148-1017-00			1	RELAY,ARMATURE 2 FORM C,10A,240VAC,COIL	12300	KUIP-11D55-12
-53	211-0724-00			2	SCREW,MACHINE 6-32 X 0.375,PNH POZ	01536	ORDER BY DESCRIPTION
-54	210-0870-00			4	WASHER,FLAT 0.141 ID X 0.312 OD X 0.05,	12327	ORDER BY DESCRIPTION
-55	210-0457-00			2	NUT,PL,ASSEM WA:6-32 X 0.312,STL CD PL	0K801	ORDER BY DESCRIPTION
-56	200-3790-00	B010100	B010117	1	COVER,PWR SPLY:ALUMINUM,	0J260	200-3790-00
	200-3790-01	B010118		1	COVER,PWR SPLY:ALUMINUM, (3001MPM ONLY)	5Y400	200-3790-01
	200-3790-00	B010100	B010180	1	COVER,PWR SPLY:ALUMINUM,	0J260	200-3790-00
	200-3790-01	B010181		1	COVER,PWR SPLY:ALUMINUM, (3001MPX ONLY)	5Y400	200-3790-01
	200-3790-01			1	COVER,PWR SPLY:ALUMINUM, (3001HSM & 2505 ONLY)	5Y400	200-3790-01
-57	211-0038-00			4	SCREW,MACHINE:4-40 X 0.312,FLH,100 DEG,STL	93907	ORDER BY DESCRIPTION
-58	334-6260-00			1	MARKER,IDENT:MKD POWER SUPPLY SHIELD	07416	PER TEKTRONIX DRAWIN
-59	348-0005-00			1	GROMMET,RUBBER:BLACK,ROUND,0.375 ID	70485	230X-36017
-60	119-3462-00			1	POWER SUPPLY:5V,20A,115/230VAC	TK1475	SOV140-1222-2(20-000
-61	212-0004-00			4	SCREW,MACHINE:8-32 X 0.312,PNH,STL	TK0435	ORDER BY DESCRIPTION
-62	343-0775-00			2	CLIP,SPR TNSN:	52152	3484-1000
-63	174-1765-00			1	CA ASSY,SP,ELEC:20,26 AWG,28.5 L	TK2469	174-1765-00
-64	210-0590-00			2	NUT,PLAIN,HEX:0.375-32 X 0.438 BRS CD PL	73743	28269-402
-65	210-0012-00			1	WASHER,LOCK:0.384 ID,INTL,0.022 THK,STL	78189	1220-02-00-0541C
-66	260-2501-00			1	SWITCH,ROCKER:DPDT,30MA,12V	7W718	1804.1153
-67	260-1967-00			1	SWITCH,SLIDE:DPDT 5A/250V 10A/125V	7W718	4021.0512
-68	210-0586-00			2	NUT,PL,ASSEM WA:4-40 X 0.25,STL CD PL	0K801	ORDER BY DESCRIPTION
-69	211-0097-00			2	SCREW,MACHINE:4-40 X 0.312,PNH,STL	93907	ORDER BY DESCRIPTION
-70	204-0833-00			1	BODY,FUSEHOLDER:3AG & 5 X 20MM FUSES	S3629	031 1653 (MODEL FEU)
-71	200-2264-00			1	CAP,FUSEHOLDER 3AG FUSES	S3629	FEK 0311666
-72	159-0015-00			1	FUSE,CARTRIDGE:3AG,3A,250V,0.65SEC	75915	312 003
	159-0021-00			1	FUSE,CARTRIDGE:3AG,2A,250V,FAST BLOW	71400	AGC-2
-73	119-3745-00			1	FILTER,RFD:LINE,3A,250V,PANEL MOUNT	TK0196	119-3745-00
-74	211-0504-00			2	SCREW,MACHINE:6-32 X 0.250,PNH,STL	TK0435	ORDER BY DESCRIPTION
-75	348-0430-00			2	BUMPER,PLASTIC:BLACK POLYURETHANE	2K262	ORDER BY DESCRIPTION
-76	131-0031-00			1	JACK,TIP:BANANA,NON-INSULATED	74970	108-0740-023
-77	210-0455-00			1	NUT,PLAIN,HEX:0.25-28 X 0.375,BRS NP	73743	3089-402
-78	210-0046-00			1	WASHER,LOCK:0.261 ID,INTL,0.018 THK,STL	78189	1214-05-00-0541C
-79	334-3379-01			1	MARKER,IDENT:MARKED GROUND SYMBOL	22670	ORDER BY DESCRIPTION

Replaceable Mechanical Parts

REPLACEABLE MECHANICAL PARTS

Fig. & Index No.	Tektronix Part Number	Serial Number Effect	Number Discont	Qty	12345 Part Name & Description	Mfr Code	Mfr Part Number
2 -80	210-0457-00			3	NUT,PL,ASSEM WA:6-32 X 0.312,STL CD PL	0KB01	ORDER BY DESCRIPTION
-81	671-0071-02	B010100	B010107	1	CIRCUIT BD ASSY:30MPM,	80009	671-0071-02
	671-0071-03	B010108		1	CIRCUIT BD ASSY:30MPM, (3001MPM ONLY)	80009	671-0071-03
	671-0069-00	B010100	B010152	1	CIRCUIT BD ASSY:30HSM	80009	671-0069-00
	671-0069-01	B010153	B010164	1	CIRCUIT BD ASSY:30HSM	80009	671-0069-01
	671-0069-02	B010165	B019999	1	CIRCUIT BD ASSY:30HSM	80009	671-0069-02
	671-0069-03	B020100	B020173	1	CIRCUIT BD ASSY:30HSM	80009	671-0069-03
	671-0069-04	B020174		1	CIRCUIT BD ASSY:30HSM (3001HSM ONLY)	80009	671-0069-04
	671-0070-02	B010100	B010156	1	CIRCUIT BD ASSY:30MPX,	80009	671-0070-02
	671-0070-03	B010157		1	CIRCUIT BD ASSY:30MPX, (3001MPX REFER TO 070-6677-XX)	80009	671-0070-03
-82	211-0246-00			11	SCR,ASSEM WSHR:4-40 X 0.625,PNH,STL,CD PL	01536	ORDER BY DESCRIPTION
-83	119-2571-00			1	DISK DRIVE:FLOPPY,;3.5 INCH,1.0 MEGABYTE	50356	FD-235F-311-2
-84	211-0328-00			4	SCREW,MACHINE:M3 X 0.5 X 10MM L,FLH,90 DEG	TK1123	ORDER BY DESCRIPTION
-85	348-0910-00			10	FOOT,CKT BD HSG:	52152	SJ5007
-86	348-1163-00			6	SHLD GSKT,ELEK:EMI,GASKETING,CADMIUM PLATED	30817	493-48
-87	671-2696-00	B020100		1	CIRCUIT BD ASSY:IDE,HARD DISK,INTERFACE (3001GPX 1M ONLY)	80009	671-2696-00
	671-2696-00	B020100		1	CIRCUIT BD ASSY:IDE,HARD DISK,INTERFACE (2505 ONLY)	80009	671-2696-00
	671-2696-00	B050100		1	CIRCUIT BD ASSY:IDE,HARD DISK,INTERFACE (3001MPX 1M ONLY)	80009	671-2696-00
	671-2696-00	B060100		1	CIRCUIT BD ASSY:IDE,HARD DISK,INTERFACE (3001HSM 1M ONLY)	80009	671-2696-00
-88	119-4483-00	B020100		1	DISK DRIVE:WINCHESTER,2.5 IN:64MB (3001GPX 1M ONLY)	65867	ORDER BY DESCRIPTION
	119-4483-00	B020100		1	DISK DRIVE:WINCHESTER,2.5 IN:64MB (2505 ONLY)	65867	ORDER BY DESCRIPTION
	119-4483-00	B050100		1	DISK DRIVE:WINCHESTER,2.5 IN:64MB (3001MPX 1M ONLY)	65867	ORDER BY DESCRIPTION
	119-4483-00	B060100		1	DISK DRIVE:WINCHESTER,2.5 IN:64MB (3001HSM 1M ONLY)	65867	ORDER BY DESCRIPTION
-89	407-4206-00	B020100		1	BRACKET,HD DISKHARD DISK,3001MPX OPT 1M (3001GPX 1M ONLY)	80009	407-4206-00
	407-4206-00	B020100		1	BRACKET,HD DISKHARD DISK,3001MPX OPT 1M (2505 ONLY)	80009	407-4206-00
	407-4206-00	B050100		1	BRACKET,HD DISKHARD DISK,3001MPX OPT 1M (3001MPX 1M ONLY)	80009	407-4206-00
	407-4206-00	B050100		1	BRACKET,HD DISKHARD DISK,3001MPX OPT 1M (3001HSM 1M ONLY)	80009	407-4206-00
-90	211-0658-00	B020100		4	SCR,ASSEM WSHR:6-32 X 0.312,PNH,STL,POZ (3001GX 1M ONLY)	78189	S51-060545-QX
	211-0658-00	B020100		4	SCR,ASSEM WSHR:6-32 X 0.312,PNH,STL,POZ (2505 ONLY)	78189	S51-060545-QX
	211-0658-00	B050100		4	SCR,ASSEM WSHR:6-32 X 0.312,PNH,STL,POZ (3001MPX 1M ONLY)	78189	S51-060545-QX
	211-0658-00	B060100		4	SCR,ASSEM WSHR:6-32 X 0.312,PNH,STL,POZ (3001HSM1M ONLY)	78189	S51-060545-QX
-91	211-0751-00	B020100		4	SCR,ASSEM WSHR M3 X 8 PAN W/FLAT & LOCK WSHR (3001GX 1M ONLY)	80009	ORDER BY DESCRIPTION
	211-0751-00	B020100		4	SCR,ASSEM WSHR M3 X 8 PAN W/FLAT & LOCK WSHR (3001GPX 1M ONLY)	80009	ORDER BY DESCRIPTION
	211-0751-00	B050100		4	SCR,ASSEM WSHR M3 X 8 PAN W/FLAT & LOCK WSHR (3001MPX 1M ONLY)	80009	ORDER BY DESCRIPTION
	211-0751-00	B060100		4	SCR,ASSEM WSHR M3 X 8 PAN W/FLAT & LOCK WSHR (3001HSM1M ONLY)	80009	ORDER BY DESCRIPTION

REPLACEABLE MECHANICAL PARTS

Fig. & Index No.	Tektronix Part Number	Serial Number		Qty	12345 Part Name & Description	Mfr Code	Mfr Part Number
		Effect	Discont				
2 -91A	210-0935-00	B020100		8	WASHER,SHLDR:0.141 ID X 0.375 OD X 0.078 THK, (3001GX 1M ONLY)	OKB01	
	210-0935-00	B020100		8	WASHER,SHLDR :0.141 ID X 0.375 OD X 0.078 THK, (2505 NLY)	OKB01	
	210-0935-00	B050100		8	WASHER,SHLDR :0.141 ID X 0.375 OD X 0.078 THK, (3001MPX 1M ONLY)	OKB01	
	210-0935-00	B060100		8	WASHER,SHLDR:0.141 ID X 0.375 OD X 0.078 THK, (3001HSM1M ONLY)	OKB01	
-92	211-0559-00	B020100		2	SCREW,MACHINE:6-32 X 0.375,FLH,100 DEG,POZ (3001GX 1M ONLY)	OKB01	
	211-0559-00	B020100		2	SCREW,MACHINE:6-32 X 0.375,FLH,100 DEG,POZ (2505 NLY)	OKB01	
	211-0559-00	B050100		2	SCREW,MACHINE:6-32 X 0.375,FLH,100 DEG,POZ (3001GPX 1M ONLY)	OKB01	
	211-0559-00	B060100		2	SCREW,MACHINE:6-32 X 0.375,FLH,100 DEG,POZ (3001MPX 1M ONLY)	OKB01	
-93	211-0658-00	B020100		2	SCR,ASSEM WSHR:6-32 X 0.312,PNH,STL,POZ (3001GX 1M ONLY)	78189	S51-060545-0X
	211-0658-00	B020100		2	SCR,ASSEM WSHR:6-32 X 0.312,PNH,STL,POZ (2505 ONLY)	78189	S51-060545-0X
	211-0658-00	B050100		2	SCR,ASSEM WSHR:6-32 X 0.312,PNH,STL,POZ (3001MPX 1M ONLY)	78189	S51-060545-0X
	211-0658-00	B060100		2	SCR,ASSEM WSHR:6-32 X 0.312,PNH,STL,POZ (3001HSM1M ONLY)	78189	S51-060545-0X
-94	174-2957-00	B020100		1	CA ASSY,SP,ELEC44,28-30 AWG,3.0 L,RIBBON (3001GX 1M ONLY)	80009	ORDER BY DESCRIPTION
	174-2957-00	B020100		1	CA ASSY,SP,ELEC44,28-30 AWG,3.0 L,RIBBON (2505 ONLY)	80009	ORDER BY DESCRIPTION
	174-2957-00	B050100		1	CA ASSY,SP,ELEC44,28-30 AWG,3.0 L,RIBBON (3001MPX 1M ONLY)	80009	ORDER BY DESCRIPTION
	174-2957-00	B060100		1	CA ASSY,SP,ELEC44,28-30 AWG,3.0 L,RIBBON (3001HSM1M ONLY)	80009	ORDER BY DESCRIPTION
-95	174-2065-00	B010283		1	CA ASSY,SP,ELEC:40,28 AWG,18.5 L,RIBBON (3001MPX 1M ONLY)	80009	174-2065-00
	174-2065-00	B020164		1	CA ASSY,SP,ELEC:40,28 AWG,18.5 L,RIBBON (3001HSM 1M ONLY)	80009	174-2065-00
	174-2065-00			1	CA ASSY,SP,ELEC:40,28 AWG,18.5 L,RIBBON (2505 ONLY)	80009	174-2065-00
	174-2065-00			1	CA ASSY,SP,ELEC:40,28 AWG,18.5 L,RIBBON (3001GX 1M ONLY)	80009	174-2065-00
-96	174-0594-00	B020164		1	CA ASSY,SP,ELEC:34,28 AWG,3.50 L,RIBBON (3001HSM 1M ONLY)	TK2469	174-0594-00
	174-0594-00	B010283		1	CA ASSY,SP,ELEC:34,28 AWG,3.50 L,RIBBON (3001MPX1M ONLY)	TK2469	174-0594-00
-97	174-2064-00	B010283		1	CA ASSY,SP,ELEC:10,28 AWG,16.0 L,RIBBON (3001MPX 1M ONLY)	80009	174-2064-00
	174-2064-00	B020164		1	CA ASSY,SP,ELEC:10,28 AWG,16.0 L,RIBBON (3001HSM 1M ONLY)	80009	174-2064-00
	174-2064-00			1	CA ASSY,SP,ELEC:10,28 AWG,16.0 L,RIBBON (2505 ONLY)	80009	174-2064-00
-98	119-3513-00	B010283		1	KEYBOARD ASSY HELVETICA KEYCAP W/RAISEDLET (2505 ONLY)	59666	ORDER BY DESCRIPTION

Replaceable Mechanical Parts

REPLACEABLE MECHANICAL PARTS

Fig. & Index No.	Tektronix Part Number	Serial Number Effect	Number Discont	Qty	12345 Part Name & Description	Mfr Code	Mfr Part Number
3 -1	161-0104-00			1	CABLE ASSY,PWR.:3,18 AWG,98 L,SVT,GREY/BLK (STANDARD,NORTH AMERICAN,120V PLUG)	0B445	MC6 -3 CG86
-2	161-0104-06			1	CABLE ASSY,PWR.:3 X 0.75MM SQ,220V,98.0 (OPTION A1,UNIVERSAL EURO,220V PLUG)	S3109	VIIGS0P0-H05VVF300,
-3	161-0104-07			1	CABLE ASSY,PWR.:3 X 0.75MM SQ,240V,98.0 (OPTION A2;UK,240V PLUG)	TK1373	A25UK-RA
-4	161-0104-05			1	CABLE ASSY,PWR.:3,18 AWG,240V,98.0 LS (OPTION A3,AUSTRALIAN,240V PLUG)	S3109	SAA/3-0D3CCFC3X0, 75
-5	161-0154-00			1	CABLE ASSY,PWR.:3,1.00MM SQ,250V,10A (OPTION A4,SWITZERLAND,220V PLUG)	S3109	12-H05VVF3G 00-5 0
-5A	161-0066-12			1	CABLE ASSY,PWR.3,18 AWG,98 L,SVT,GREY/BLK,60 (OPTION A4,SWITZERLAND,220V PLUG 2505 ONLY)	29870	ORDER BY DESCRIPTION
-6	174-1851-00			1	CA ASSY,SP,ELEC:2 X 3,26 AWG,16.0 L	TK2469	174-1851-00
-7	174-1852-00			1	CA ASSY,SP,ELEC:2 X 3,26 AWG,9.0 L	TK2469	174-1852-00
-8	174-1767-00			1	CA ASSY,SP,ELEC:5,16 AWG,19.0 L	TK2469	174-1767-00
-9	174-1984-00	B010100	B019999	1	CA ASSY,SP,ELEC:34,28 AWG,10.0 L,RIBBON	TK2469	174-1984-00
	174-2063-00	B020100	B050130	1	CA ASSY,SP,ELEC:34,28 AWG,W/VINYL JKT,17.5L	80009	174-2063-00
	174-3143-00	B050131		1	CA ASSY,SP,RIBBON;IDC10,28 AWG,1.75L 2 X 5 (3001MPX)	TK2469	174-3143-00
	174-1984-00	B010100	B020177	1	CA ASSY,SP,ELEC:34,28 AWG,10.0 L,RIBBON	TK2469	174-1984-00
	174-2063-00	B020178	B060111	1	CA ASSY,SP,ELEC:34,28 AWG,W/VINYL JKT,17.5L	80009	174-2063-00
	174-3143-00	B060112		1	CA ASSY,SP,RIBBON;IDC10,28 AWG,1.75L 2 X 5 (3001HSM)	TK2469	174-3143-00
-10	174-1987-00			1	CA ASSY,SP,ELEC:3,26 AWG,15.0 L,RIBBON	TK2469	174-1987-00
-11	174-1986-00			1	CA ASSY,SP,ELEC:3,18 AWG,15.0 L	TK2469	174-1986-00
-12	174-1985-00	B010100	B019999	1	CA ASSY,SP,ELEC:4,26 AWG,10.0 L,RIBBON	TK2469	174-1985-00
	174-2063-00	B020100		1	CA ASSY,SP,ELEC:4,26 AWG,16.0 L,RIBBON (3001MPX)	80009	174-2062-00
	174-1985-00	B010100	B020177	1	CA ASSY,SP,ELEC:4,26 AWG,10.0 L,RIBBON	TK2469	174-1985-00
	174-2063-00	B020178		1	CA ASSY,SP,ELEC:4,26 AWG,16.0 L,RIBBON (3001HSM)	80009	174-2062-00
-13	174-1764-00			1	CA ASSY,SP,ELEC:26,26 AWG,24.0 L,RIBBON	TK2469	174-1764-00
-14	174-1765-00			1	CA ASSY,SP,ELEC:20,26 AWG,28.5 L	TK2469	174-1765-00
-15	174-1766-00			1	CA ASSY,SP,ELEC:12,16 AWG,16.5 L	TK2469	174-1766-00
-16	174-1855-00			1	CA ASSY,SP,ELEC:2,18 AWG,18.0 L	TK2469	174-1855-00
-17	196-3281-00			12	LEAD,ELECTRICAL:14 AWG,5.5 L,RED	TK2469	196-3281-00
-18	174-1857-00			1	CA ASSY,SP,ELEC:18 AWG,6.0 L	TK2469	174-1857-00
-19	174-1983-00			1	LEAD ASSY,ELEC:BRANCHED,2,18 AWG,4.0/6.0	TK2469	174-1983-00
-20	196-3284-00			1	LEAD,ELECTRICAL:18 AWG,4.00 L	TK2469	196-3284-00
-21	174-1988-00			1	CA ASSY,SP,ELEC:2,12 AWG,4.0 L	TK2469	174-1988-00
-22	174-1989-00			1	CA ASSY,SP,ELEC:2,18 AWG,6.0 L	TK2469	174-1989-00
-23	174-1152-00			1	CA ASSY,SP:SHLD RIBBON,;IDC,26,30 AWG,48.0	1Y013	63827
-24	174-1391-00	B010100	B040100	1	CA ASSY,SP,ELEC:24,28 AWG,9.00 L	80009	174-1391-00

STANDARD ACCESSORIES

062-9892-09				1	SOFTWARE PKG:3000 SERIES SYSTEM SOFTWARE	80009	062-9892-01
063-0191-02				1	SOFTWARE PKG:30MPM/MPX	80009	063-0191-00
063-0165-04				1	SOFTWARE PKG:3000 SERIES SYSTEM DIAGNOSTICS	80009	ORDER BY DESCRIPTION
063-0200-01				1	SOFTWARE PKG:3001MPM/MPX DIANOSTIC SYSTEM SW	80009	063-0200-01
063-0201-00				1	SOFTWARE PKG:3001HSM DIAGNOSTIC SOFTWARE	80009	063-0201-00
062-9898-09				1	SOFTWARE PKG:5200 SYSTEM SOFTWARE	80009	062-9898-09
062-9925-06				1	SOFTWARE PKG:2500 SERIES SYSTEM DIAGNOSTICS	80009	062-9926
070-6672-04				1	MANUAL,TECH:USERS,PRISM 3001HSM/MPX	80009	070-6672-04
070-6673-00				1	MANUAL,TECH:USERS,30MPM/MPX671-0070-00	80009	070-6673-00
070-6674-01				1	MANUAL,TECH:USERS,30HSM,671-0069-XX	80009	070-6674-01
070-7007-01				3	MANUAL,TECH:REF GUIDE,PRISM 3002 SERIES	80009	070-7007-00

REPLACEABLE MECHANICAL PARTS

Fig. & Index No.	Tektronix Part Number	Serial Number Effect	Number Discont	Qty	12345 Part Name & Description	Mfr Code	Mfr Part Number
OPTIONAL ACCESSORIES							
	012-1277-00	B010100	B010167	1	CABLE, INTCOON:2GHZ LEADSET	80009	012-1277-00
	012-1277-01	B010168		1	CABLE INTCOON:2GHZ LEADSET	80009	012-1277-01
	070-6676-01			1	MANUAL , TECH:USERS ,PRISM 3001HSM/MPX	80009	070-6672-04
	070-6677-00			1	MANUAL , TECH:USERS ,30MPM/MPX671-0070-XX	80009	070-6673-00
	070-6678-02			1	MANUAL , TECH:SERVICE ,30HSM 671-0069-XX	80009	070-6678-02
	070-7413-02			3	MANUAL , TECH:REF GUIDE ,PRISM 3002 SERIES	80009	070-7413-02

PLEASE INSERT 3 FOLDED

11 X 17 Z-FOLD(S)

2-1-94

PART NUMBER: 070-6676-01

1	1	DIA. + CIRCUIT * HARD DISK
1	2	1 OF 7 * BLANK
1	3	2 OF 7 * BLANK
1	4	3 OF 7 * BLANK
1	5	4 OF 7 * BLANK
1	6	5 OF 7 * BLANK
1	7	6 OF 7 * BLANK
1	8	7 OF 7 * KEY BOARD LOCATIONS
1	9	KEY BOARD FILTER * BLANK
1	10	FLOPPY DRIVE * BLANK
1	11	COMM PACK * POWER DIST. BOARD
1	12	POWER * BLANK
1	13	CONNECTOR * BLANK
1	14	① * BLANK
2	15	FIG. 1 * BLANK
2	16	FIG. 2 * BLANK
2	17	FIG. 3 * BLANK
	18	

